

NEW

ADVANCED WATERJET DRIVE

TURBODRIVE 240 H.C.T. / L.V.T.

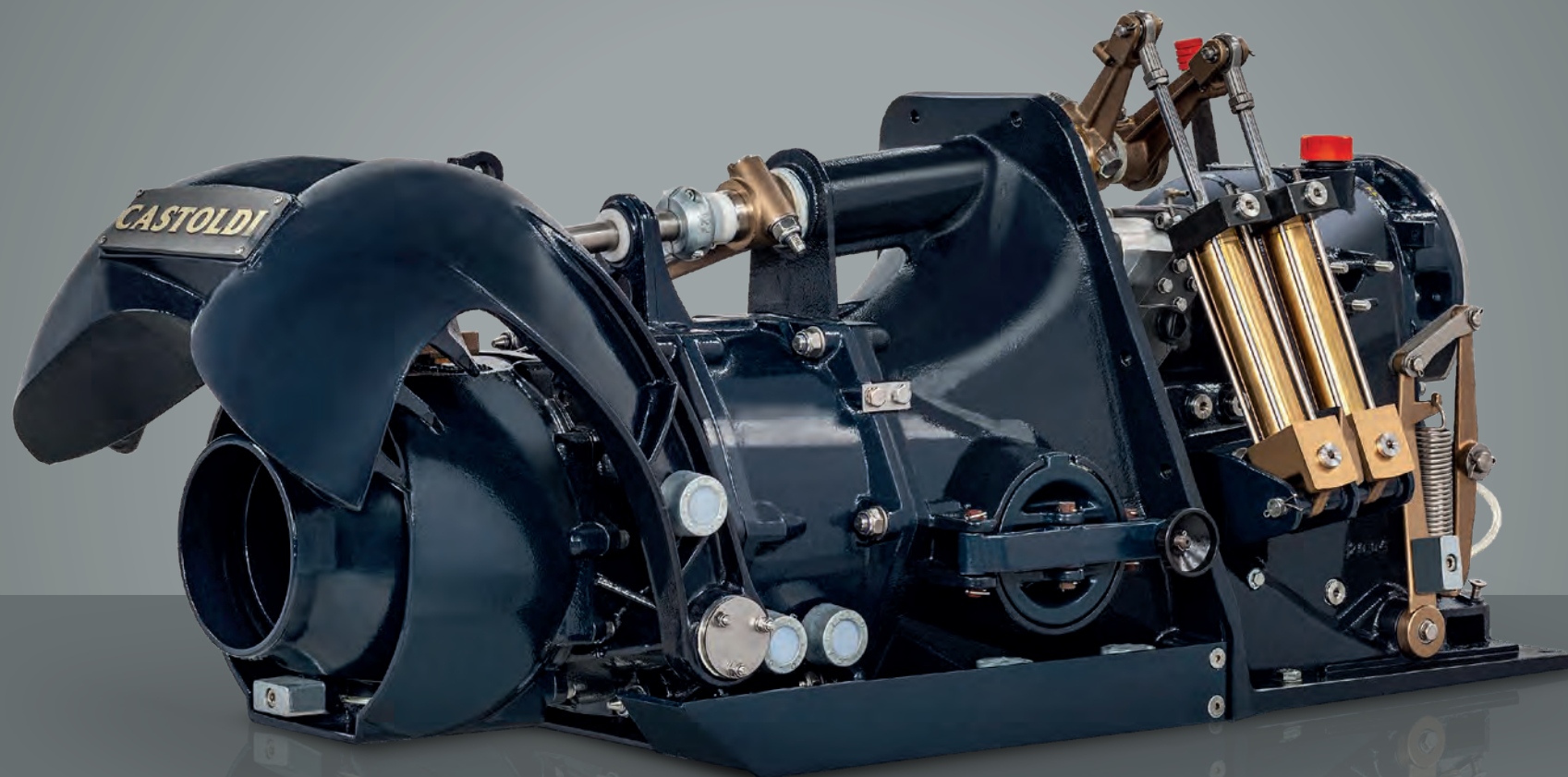

CASTOLDI

Since 1962
Forerunners, always

Turbodrive 240 H.C.T. is the most compact and light model of the range equipped with the integrated gearbox and hydraulic multi-disc clutch. The main components have been designed with the help of the most advanced and recent CFD softwares, so to achieve performance even higher than its precursor, the Turbodrivo 240 H.C.

The static and dynamic thrusts are significantly increased, as well as the resistance to cavitation, thanks to the new micro-cast 4 blades axial flow impeller made in AISI 316 L stainless steel. The new nozzle improves the steering control allowing tight turns with a limited loss of speed.

Turbodrive 240 H.C.T. can be now equipped with the Clear-Duct advanced unclogging system (that operates simultaneously the reversing of the impeller rotation and the opening of the intake grid) and a wide choice of Castoldi controls including the high-end electronic **ACES**.

Turbodrive 240 H.C.T. redefines the quality and performance standards of the category: its compact dimensions and many unique features make it the lightest, most complete and efficient waterjet of its class on the market.

#Thrust #Compactness #Lightness #Durability

The Castoldi impeller is a true axial inducer type design and is recognized as having the best efficiency, cavitation resistance and lowest weight compared to any other type of pump.

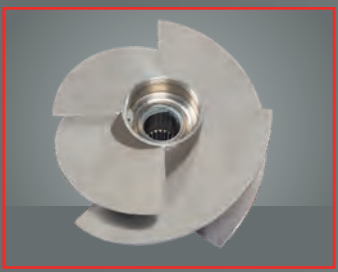

New high efficiency reversing bucket and steering nozzle design

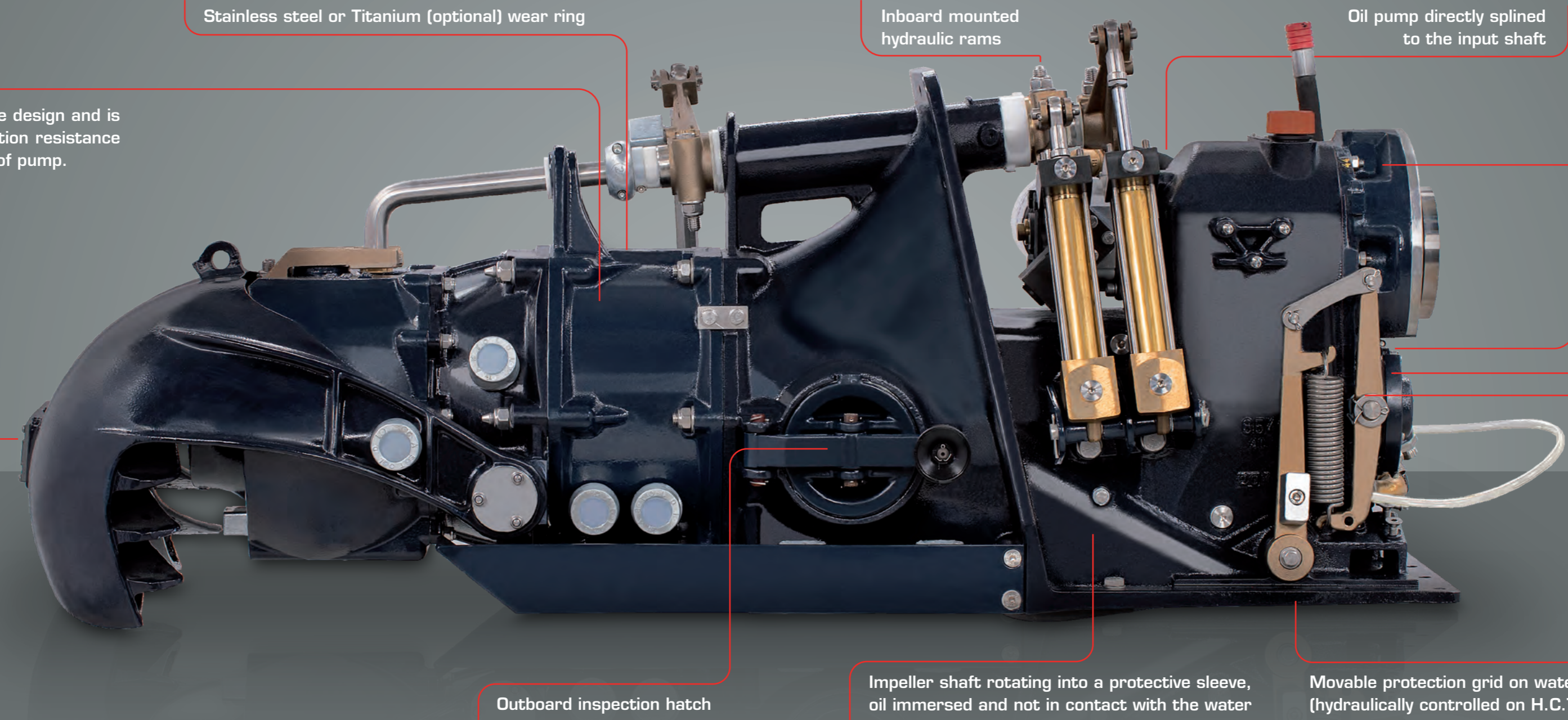

Stainless steel or Titanium (optional) wear ring

Inboard mounted hydraulic rams

Oil pump directly splined to the input shaft

Integrated heavy duty gearbox with N. 18 gear ratios available

Clear-Duct unclogging system (optional for H.C.T.). Performs the synchronized operations of impeller rotation reversing and intake grid opening

Built-in multi-disc hydraulic clutch (not present on L.V.T)

Electric/hydraulic control of the movable protection grid (optional for H.C.T.)

Outboard inspection hatch

Impeller shaft rotating into a protective sleeve, oil immersed and not in contact with the water

Movable protection grid on water intake with hydrodynamically profiled set of bars (hydraulically controlled on H.C.T., mechanically controlled on L.V.T.)

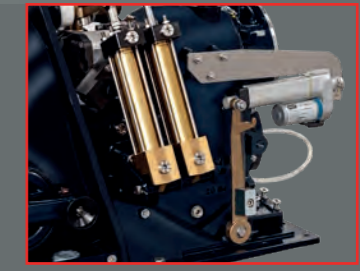

TURBODRIVE 240 H.C.T. / L.V.T.



- **The highest thrust and best performance**

Assured by the new component design.

- **The most effective defense against marine corrosion**

Assured by the hard anodizing treatment protecting all the aluminium alloy components with 60 microns thickness of aluminum oxide (ceramic), three layers of special paint and cathodic protection by sacrificial anodes.

- **The most efficient anti-clogging system**

Assured by the Clear-Duct system (optional for H.C.T.) performing the simultaneous electrically controlled operations of impeller rotation reversing and the intake grid opening.



- **The highest suitability to operate in sandy, dirty and shallow waters**

Thanks to the impeller shaft rotating into a protective sleeve, oil immersed and not in contact with the water.

- **The longest operational life**

Thanks to the presence of all oil lubricated bearings.

- **The most compact installation**

Thanks to the presence of the built-in gearbox and hydraulic multi-disc clutch.

Dimensions

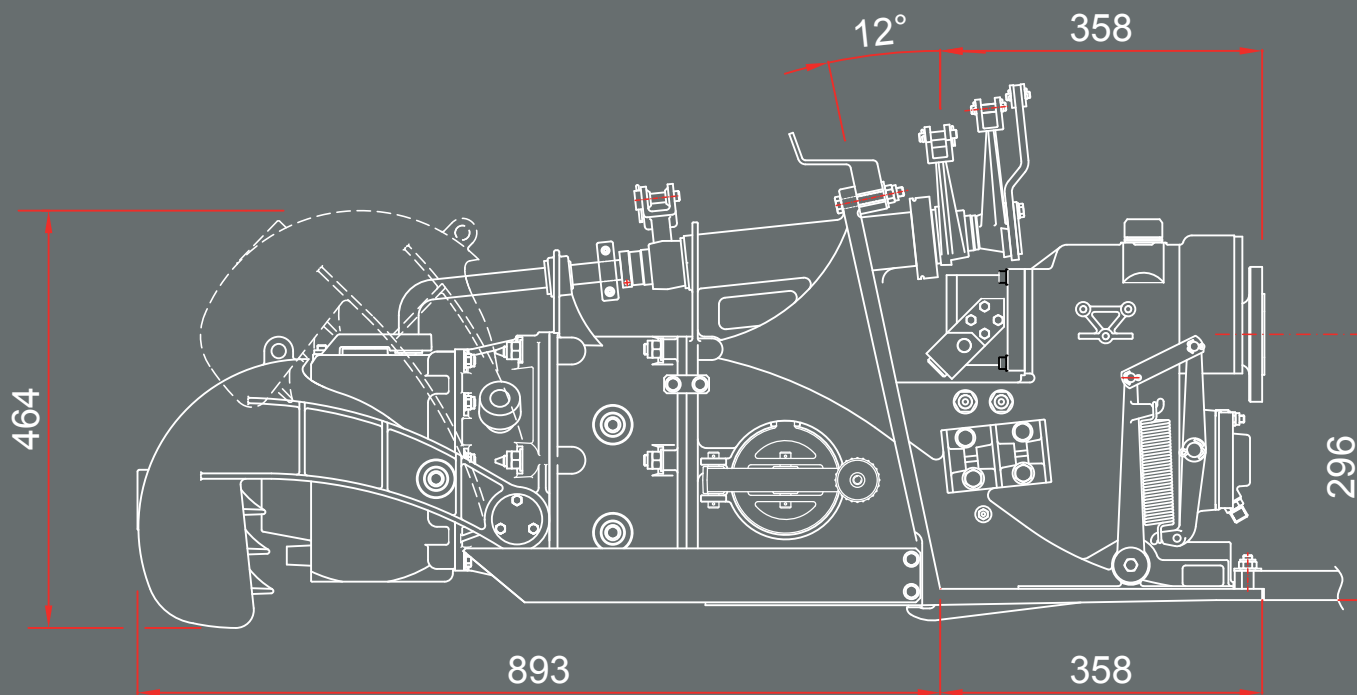
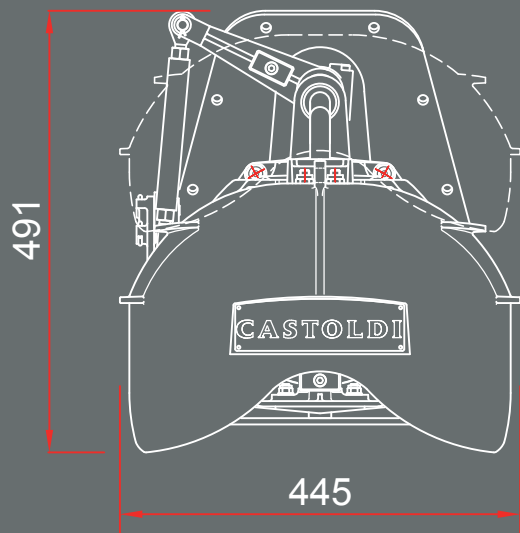
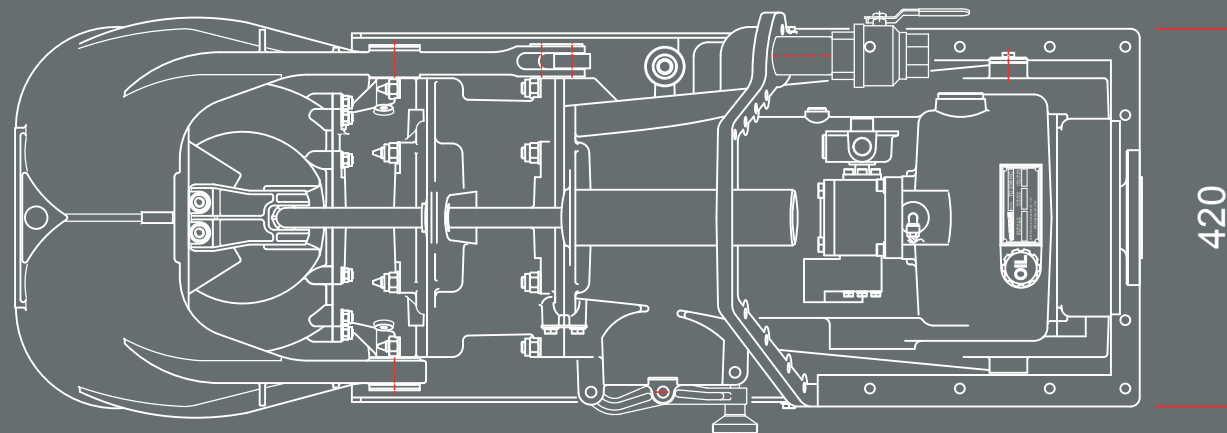
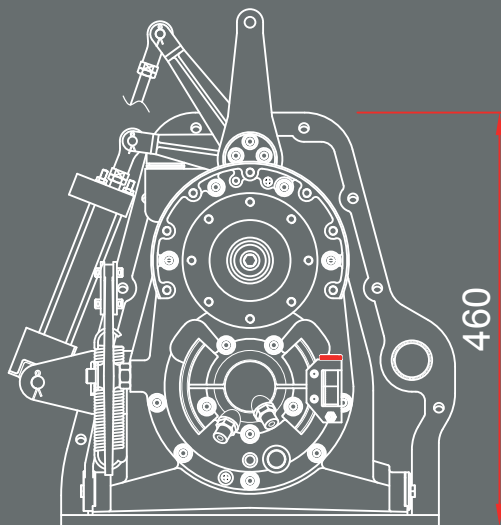

TURBODRIVE 240 H.C.T. / L.V.T.

Impeller: AISI 316 L

Impeller housing: G.AI.SI.9 aluminum alloy

Impeller housing wear ring: Stainless steel or Titanium (optional)

Impeller shaft: Aquamet 17 stainless steel

Input shaft: 39 NI.CR.MO. 3 high grade steel

Stator: G.AI.SI.7 aluminum alloy

Steering nozzle and reversing bucket: G.AI.SI.7 aluminum alloy

Steering shaft: AISI 316

Reversing shaft: AISI 316 stainless steel

Waterjet body: G.AI.SI.9 aluminum alloy

Gear wheels: Surface carbo hardened high grade 18 NI.CR.MO. 5 steel

The whole unit is protected by a hard anodizing treatment, plating all light-alloy components with 60 microns thickness of aluminum oxide (ceramic), three layers of special paint and cathodic protection by zinc anodes

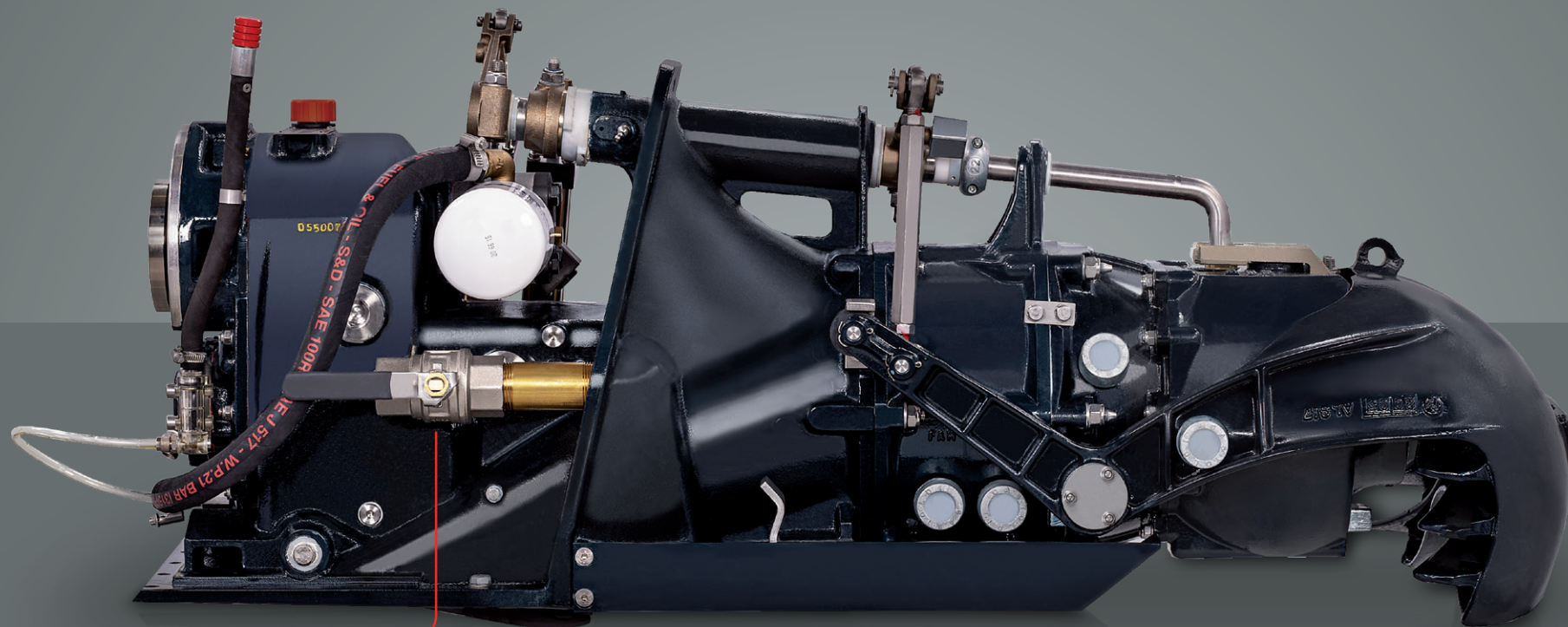

Water pickup for engine cooling

Technical specifications

MAXIMUM SUGGESTED DISPLACEMENT (t)

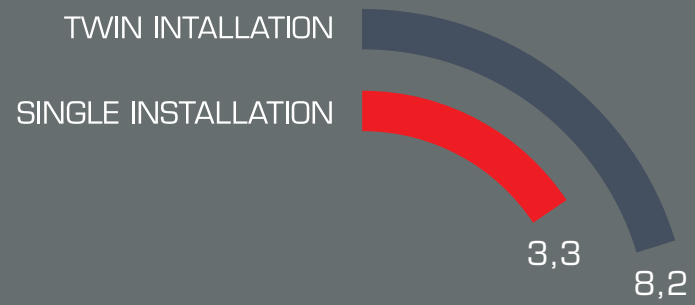

MAX POWER INPUT (kW)

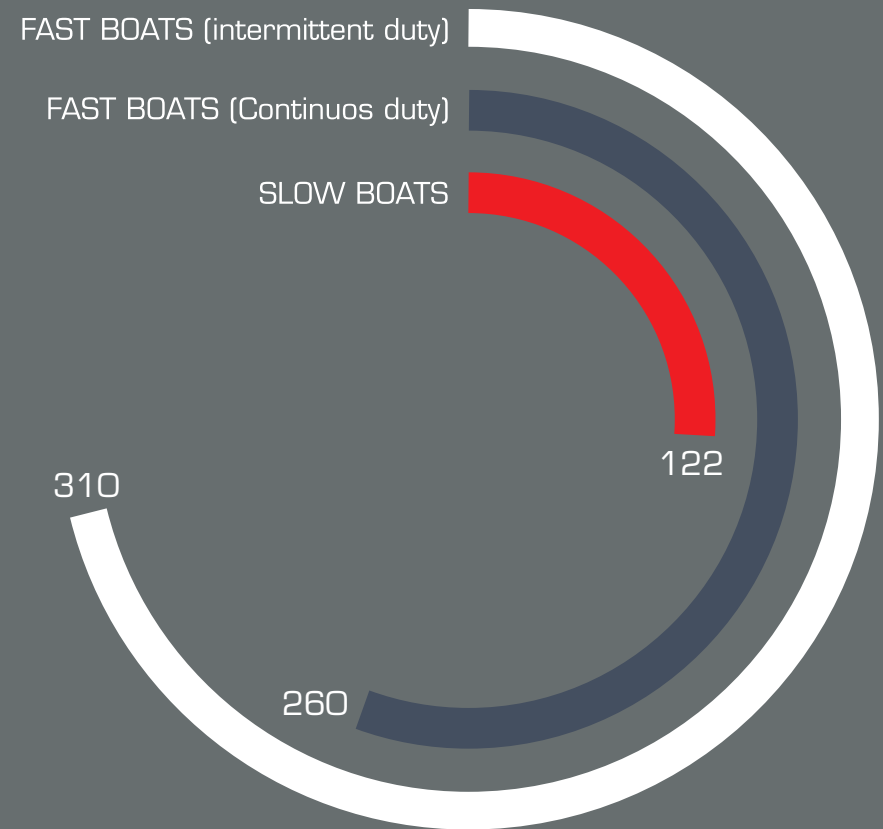

TURBODRIVE 240 H.C.T. / L.V.T.

Impeller: N.4 blades, single stage, axial flow

Impeller diameter: 238 mm at the inlet

Stator: N. 5 blades

Integrated heavy duty gearbox: With N.18 gear wheels ratio available

Input flange: Suit up to 150 mm diameter drive shaft flange

Impeller disconnecting/connecting system (not present on L.V.T.): Built-in multi-disc hydraulic clutch

Transom angle: 12°

Drive shaft rotation: Clockwise looking at the input driveshaft flange

Inspection hatch: Outboard

Hydraulic actuators: All inboard, waterjet mounted

Water pick-up for engine cooling: 1" 1/4 GAS

Hydraulic power unit and accessories: Incorporated hydraulic pump directly splined to the input shaft for the waterjet power controls. Solenoid valves and piping complete the hydraulic plant (all inboard, waterjet mounted)

Unit dry weight (including gearbox, hydraulic clutch, water intake, grid, duct, anodes etc.): 130 kg

Hydraulic weight (oil pump, actuators, solenoid valves, brackets): 21 kg

Entrained water volume: 26 l

Oil volume: 6 kg "SAE 30" Uni-Grade oil type (gearbox and hydraulics)

B.P.R.: Additional water intake for take-off improvement

Water intake protection: Movable debris screen grid with double set of hydrodynamically profiled bars

Bearings: All oil lubricated

Clear-Duct unclogging system (optional for H.C.T.): Superior unclogging system by simultaneous operations of impeller reversing and intake grid opening, 12 kg

Reversing system: Castoldi compact "Multi-Duct" reversing bucket. (65% of the forward static thrust)

Steering system: Castoldi steering nozzle integrated in a protective bowl

Version comparison

	TURBODRIVE 240 H.C.T.	TURBODRIVE 240 L.V.T.
Integrated gearbox	Yes	Yes
Hydraulic clutch	Yes	No
Neutral dashboard switch	No	Optional
Movable debris screen grid	mechanically/hydraulically operated	Mechanically operated
Clear-Duct unclogging system	Optional	No
B.P.R.	Yes	Yes
Mechanical/hydraulic control	Yes	Yes
Electric/hydraulic control	Yes	Yes
Electronic/hydraulic control (ACES)	Yes	No



CASTOLDI

Since 1962
Forerunners, always

Castoldi S.r.L.

Strada Provinciale 114 n. 10 · 20080 Albairate (Milan) · ITALY
Tel : +39 02 9401881 · Fax : +39 02 94018850 · info@castoldijet.it

www.castoldijet.it



castoldijet