

ADVANCED WATERJET DRIVE

TURBODRIVE 284 H.C.T. / L.V.T.



**CASTOLDI**

Since 1962  
Forerunners, always

Castoldi is proud to introduce **Turbodrive 284 H.C.T. / L.V.T.**, the first model of a new ground braking waterjet family, which creation and the striking performance capabilities are the results of years of research and development using the most sophisticated CFD softwares, along with fluid dynamics studies and testing.

---

It incorporates the newly researched design improvements that lead to a higher static thrust and increased speed efficiency compared to the previous model. Besides, the new optimized steering and reversing actuators grant an higher precision with minimal performance loss while turning and an astonishing crash stop capability.

---

**Turbodrive 284 H.C.T. / L.V.T.** is a true complete propulsion system, combining the typical unique features of the Castoldi design, that represents the best choice for high speed commercial, military and pleasure applications.

---

**#Thrust #Compactness #Lightness #Durability**

The Castoldi impeller is a true axial inducer type design and is recognized as having the best efficiency, cavitation resistance and lowest weight compared to any other type of pump.

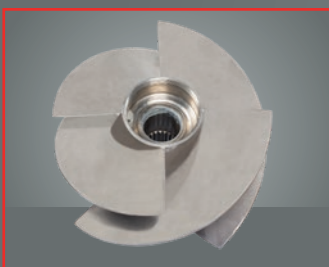

New high efficiency reversing bucket and steering nozzle design



Stainless steel or Titanium (optional) wear ring

Inboard mounted hydraulic rams

Oil pump directly splined to the input shaft

Integrated heavy duty gearbox with N. 25 gear ratios available

Clear-Duct unclogging system (optional for H.C.T.). Performs the synchronized operations of impeller rotation reversing and intake grid opening

Built-in multi-disc hydraulic clutch (not present on L.V.T)

Outboard inspection hatch

Impeller shaft rotating into a protective sleeve, oil immersed and not in contact with the water

Movable protection grid on water intake with hydrodynamically profiled set of bars (hydraulically controlled on H.C.T., mechanically controlled on L.V.T.)

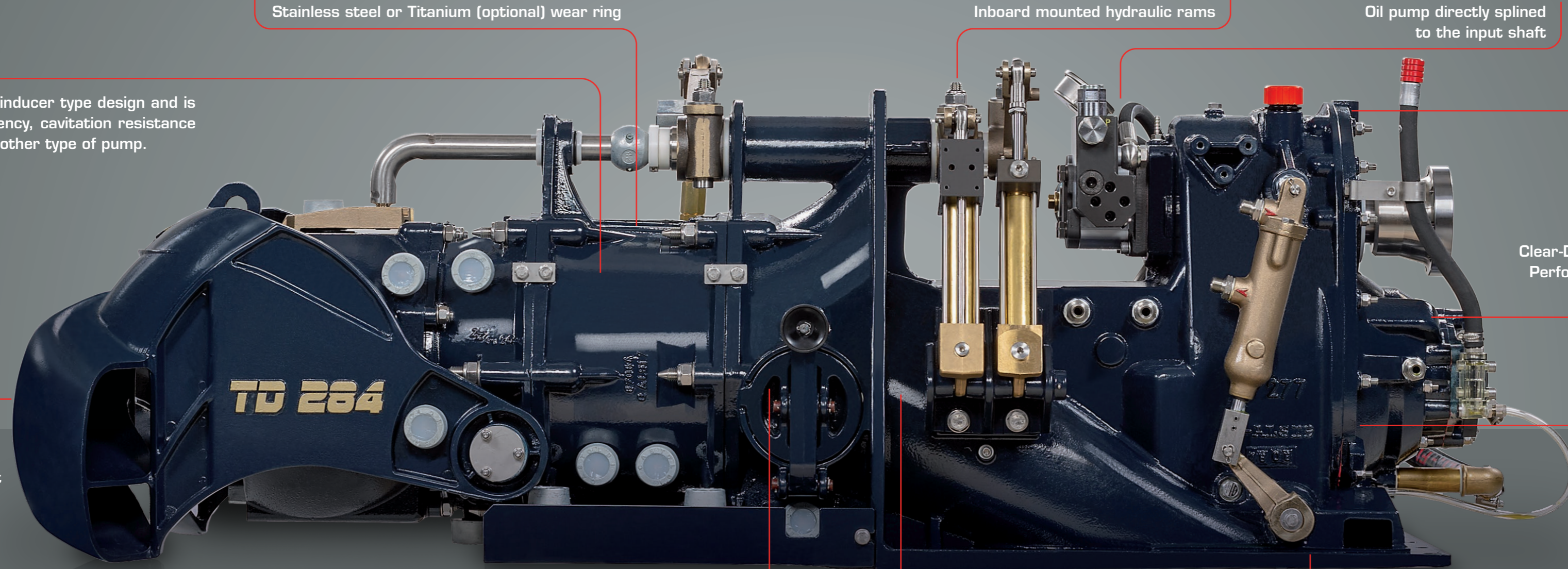

## TURBODRIVE 284 H.C.T. / L.V.T.



- **The highest thrust and best performance**

Assured by the new component design.

---

- **The most effective defense against marine corrosion**

Assured by the hard anodizing treatment protecting all the aluminium alloy components with 60 microns thickness of aluminum oxide (ceramic), three layers of special paint and cathodic protection by sacrificial anodes.

---

- **The most efficient anti-clogging system**

Assured by the Clear-Duct system (optional for H.C.T.) performing the simultaneous electrically controlled operations of impeller rotation reversing and the intake grid opening.

---

- **The highest suitability to operate in sandy, dirty and shallow waters**

Thanks to the impeller shaft rotating into a protective sleeve, oil immersed and not in contact with the water.

---

- **The longest operational life**

Thanks to the presence of all oil lubricated bearings.

---

- **The most compact installation**

Thanks to the presence of the built-in gearbox and hydraulic multi-disc clutch.



# Dimensions

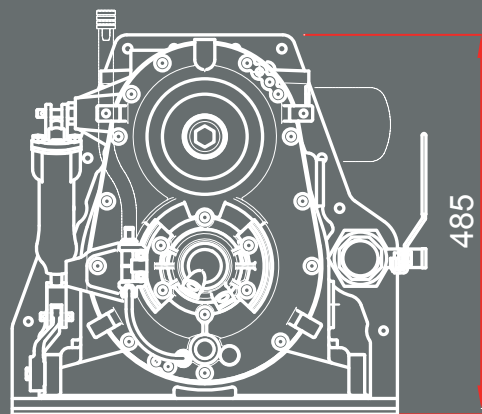

485

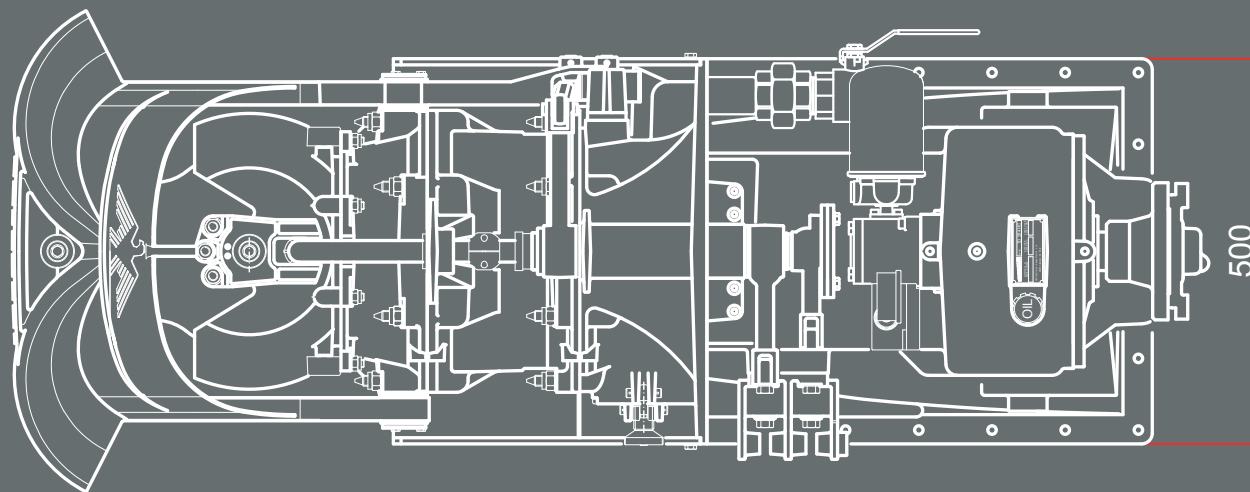

500

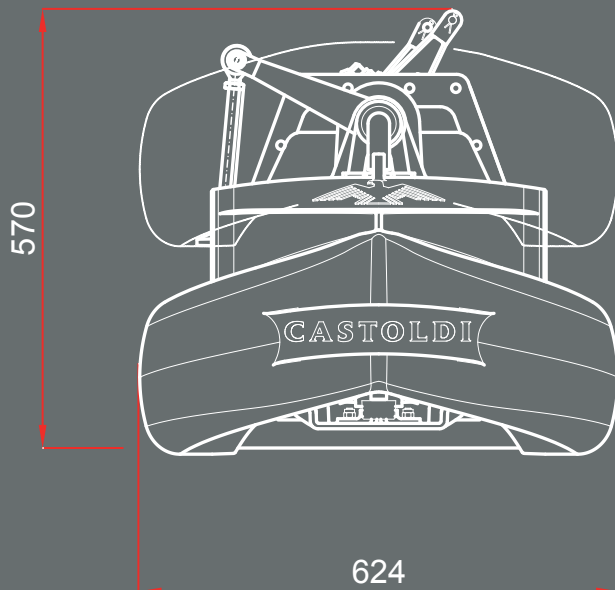

570

624

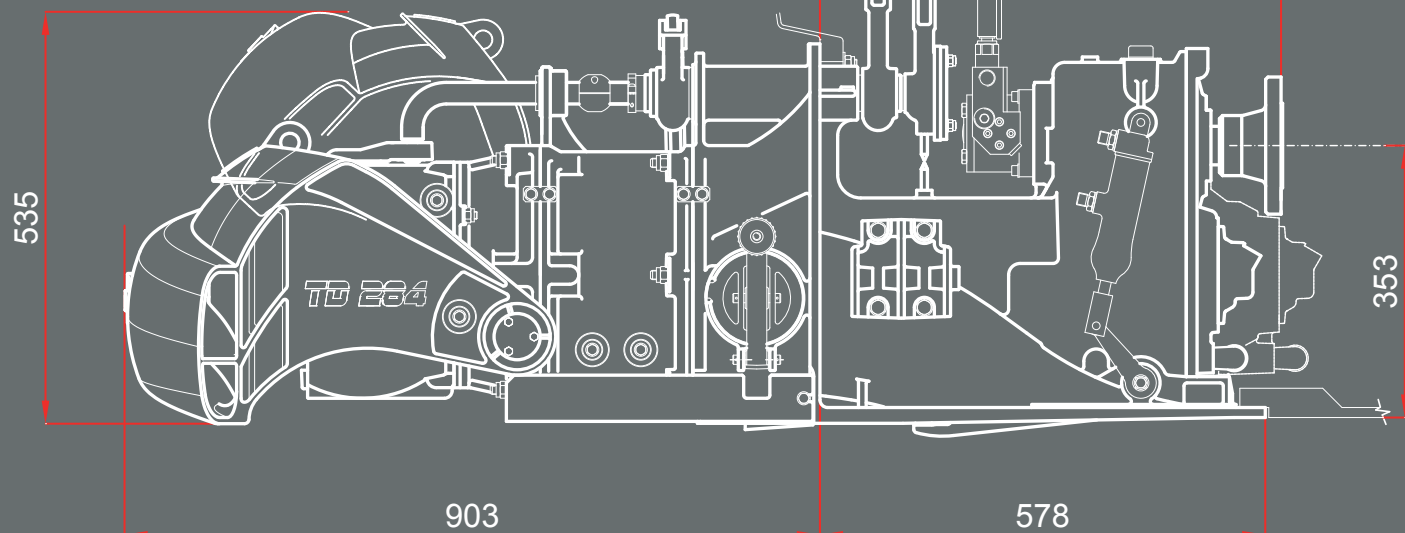

535

903

598,5

578

353

## TURBODRIVE 284 H.C.T. / L.V.T.

**Impeller:** AISI 316 L

**Impeller housing:** G.AI.SI.9 aluminum alloy

**Impeller housing wear ring:** Stainless steel or titanium (optional)

**Impeller shaft:** Aquamet 17 stainless steel

**Input shaft:** 39 NI.CR.MO. 3 high grade steel

**Stator:** G.AI.SI.7 aluminum alloy

**Steering nozzle and reversing bucket:** G.AI.SI.7 aluminum alloy

**Steering shaft:** AISI 316

**Reversing shaft:** AISI 316 stainless steel

**Waterjet body:** G.AI.SI.9 aluminum alloy

**Gear wheels:** Surface carbo hardened high grade 18 NI.CR.MO. 5 steel

The whole unit is protected by a hard anodizing treatment, plating all light-alloy components with 60 microns thickness of aluminum oxide (ceramic), three layers of special paint and cathodic protection by zinc anodes

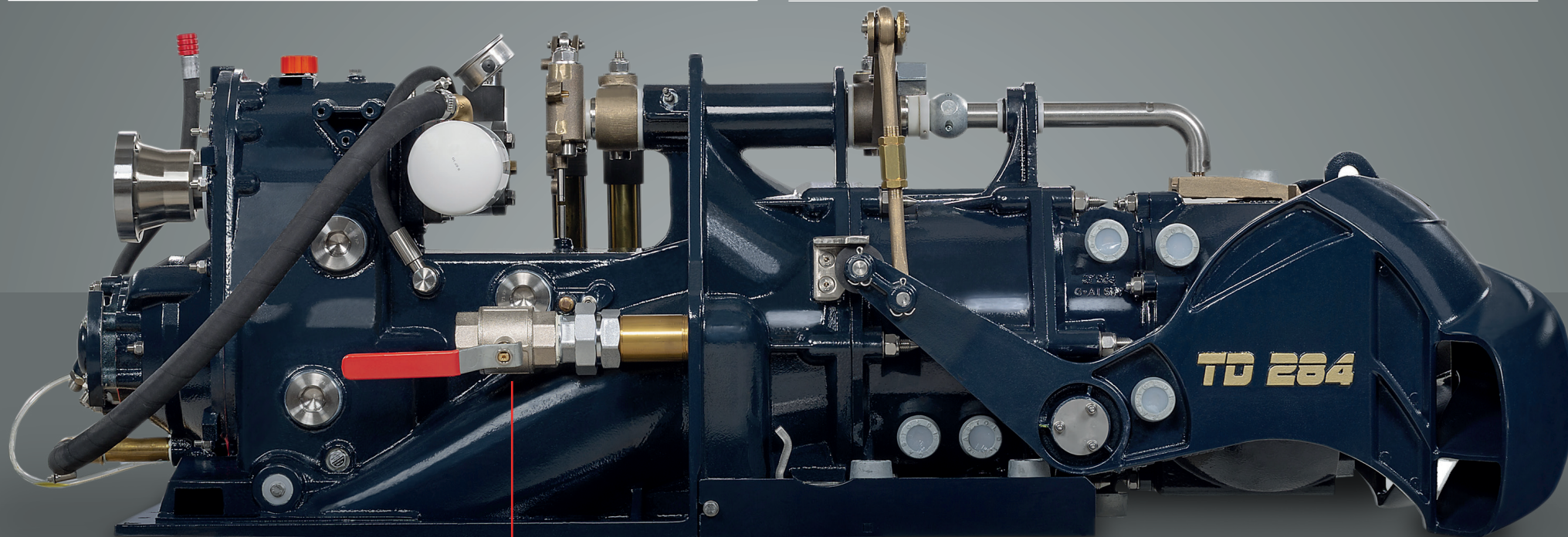

Water pickup for engine cooling

MAXIMUM SUGGESTED DISPLACEMENT (t)

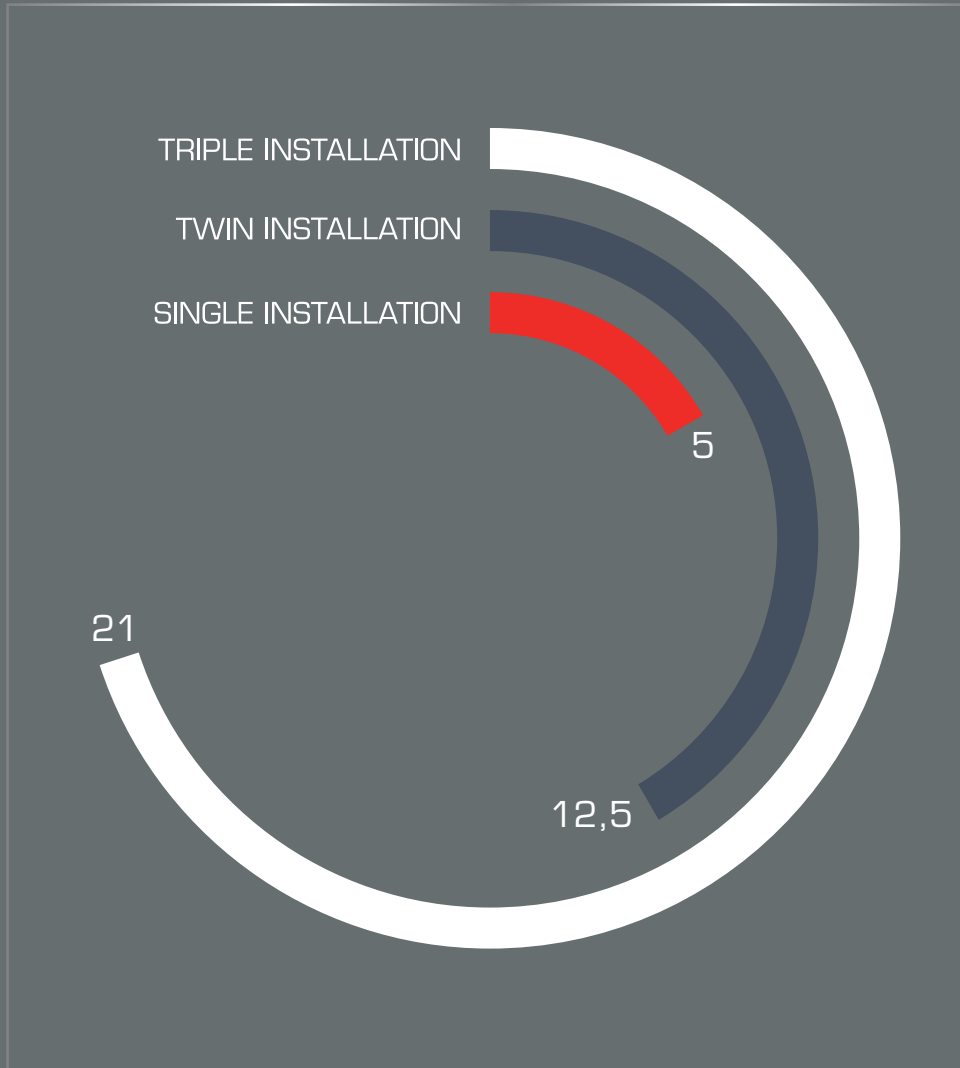

MAX POWER INPUT (kW)

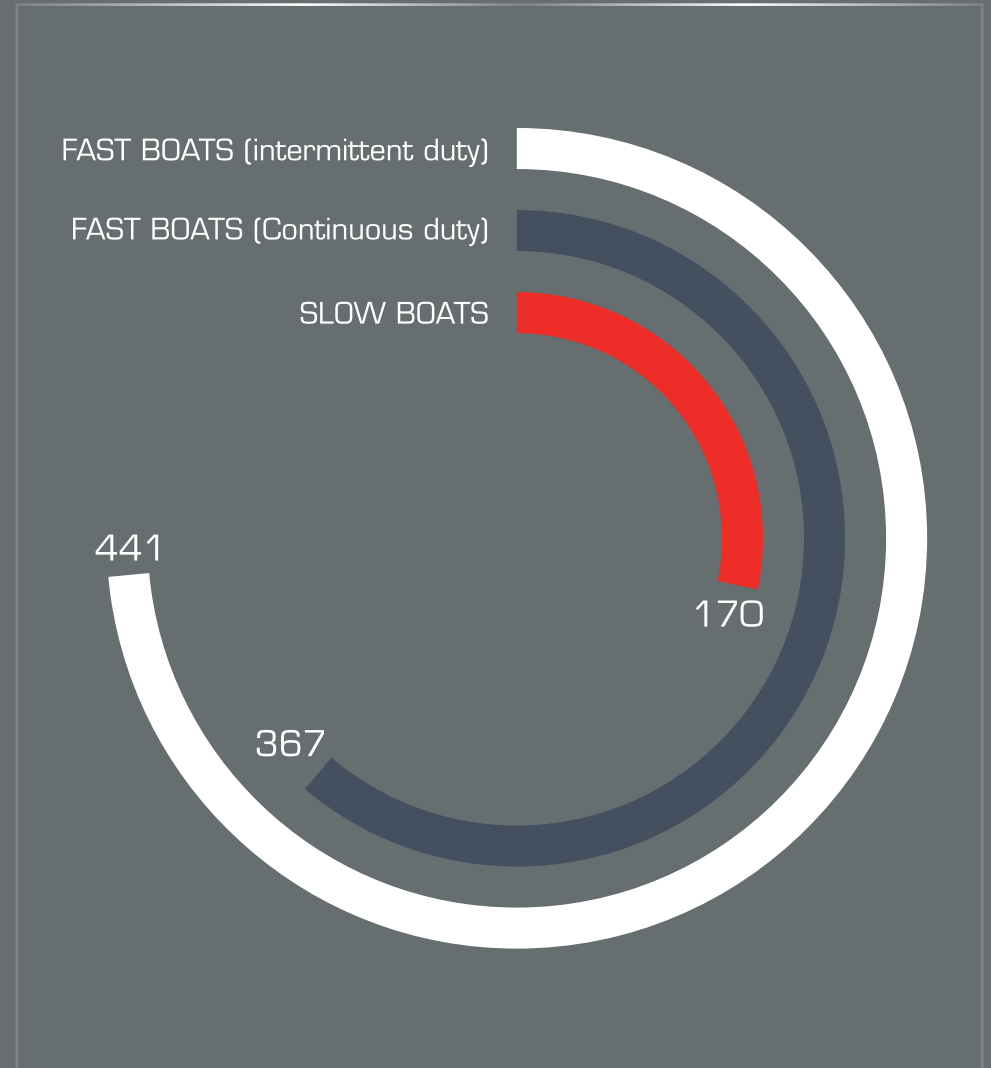

## TURBODRIVE 284 H.C.T. / L.V.T.

Impeller: N.4 blades, single stage, axial flow

Impeller diameter: 282 mm at the inlet

Stator: N. 5 blades

Integrated heavy duty gearbox: With N.25 gear wheels ratio available

Input flange: Suit up to 180 mm diameter drive shaft flange

Impeller disconnecting/connecting system (not present on L.V.T.): Built-in multi-disc hydraulic clutch

Transom angle: 90°

Drive shaft rotation: Clockwise looking at the input driveshaft flange

Inspection hatch: Outboard

Hydraulic actuators: All inboard, waterjet mounted

Water pick-up for engine cooling: 1" 1/2 GAS

Hydraulic power unit and accessories: Incorporated hydraulic pump directly splined to the input shaft for the waterjet power controls. Solenoid valves and piping complete the hydraulic plant (all inboard, waterjet mounted)

Unit dry weight (including gearbox, hydraulic clutch, water intake, grid, duct, anodes etc.): 190 kg (180 kg L.V.T.)

Hydraulic weight (oil pump, actuators, solenoid valves, brackets): 31 kg

Entrained water volume: 45 l

Oil volume: 9 kg "SAE 30" Uni-Grade oil type (gearbox and hydraulics)

B.P.R.: Additional water intake for take-off improvement

Water intake protection: Movable debris screen grid with double set of hydrodynamically profiled bars

Bearings: All oil lubricated

Clear-Duct unclogging system (optional for H.C.T.): Superior unclogging system by simultaneous operations of impeller reversing and intake grid opening, 14 kg

Reversing system: Castoldi compact "Twin-Duct" reversing bucket. (75% of the forward static thrust)

Steering system: Castoldi steering nozzle integrated in a protective bowl



## Version comparison

	<b>TURBODRIVE 284 H.C.T.</b>	<b>TURBODRIVE 284 L.V.T.</b>
Integrated gearbox	Yes	Yes
Hydraulic clutch	Yes	No
Neutral dashboard switch	No	Optional
Movable debris screen grid	Hydraulically operated	Mechanically operated
Clear-Duct unclogging system	Optional	No
B.P.R.	Yes	Yes
Mechanical/hydraulic control	Yes	Yes
Electric/hydraulic control	Yes	Yes
Electronic/hydraulic control (ACES)	Yes	No



**CASTOLDI**

Since 1962  
Forerunners, always

---

Castoldi S.r.L.

Strada Provinciale 114 n. 10 · 20080 Albairate (Milan) · ITALY  
Tel : +39 02 9401881 · Fax : +39 02 94018850 · info@castoldijet.it

[www.castoldijet.it](http://www.castoldijet.it)



castoldijet