

1100 Series 1104D-E44TAG1 Diesel Engine – Electropak

90.8 kW @ 1800 rev/min

The 1104D-E44TAG Electropaks are the latest addition to Perkins 1100 Series Electric Power line-up. Offering improved power density from a compact package, these Electropak's build on Perkins 1100 Series reputation within the Power Generation Industry.

These ultra clean engines are assembled on a new high technology production line. Frequent computerised checks during the production process ensure high build quality is maintained throughout.

Hitting the key power nodes required by the market, the 1104D Electropak product line-up consists of three models offering a power solution for both Prime and Standby applications, in 60 Hz territories.

Power to meet your needs

Hitting the key power nodes required by the market, the 1104D-E44TAG1 Electropak has been developed to provide a clean and cost effective power solution.

State of the art design

The 1104D utilises the latest common-rail fuel system technologies with a closely optimised air-management system, which is overseen by the latest generation of electronic engine control. This allows the 1104D range to deliver high power density and excellent fuel economy with low exhaust emissions and minimum heat rejection.

Worldwide power solution

The 1104D has been designed to be worldwide fuel tolerant, and 5% biofuel (RME) options are available to meet local market needs.

Product support

- Perkins actively pursues product support excellence by ensuring our distribution network invest in their territory – strengthening relationships and providing more value to you, our customer

- Through an experienced global network of distributors and dealers, fully trained engine experts deliver total service support around the clock, 365 days a year. They have a comprehensive suite of web based tools at their fingertips covering technical information, parts identification and ordering systems, all dedicated to maximising the productivity of your engine
- Throughout the entire life of a Perkins engine, we provide access to genuine OE specification parts and service. We give 100% reassurance that you receive the very best in terms of quality for lowest possible cost .. wherever your Perkins powered machine is operating in the world

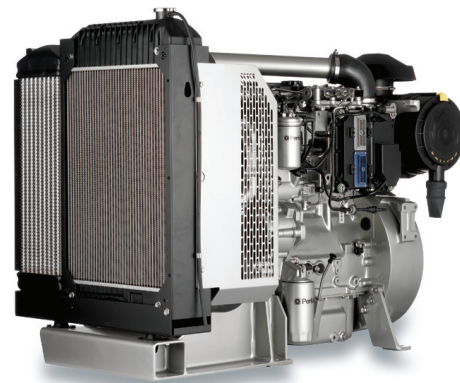

Lower operating costs

The 1104D maintains Tier 2 fuel economy. This will allow many customers to keep existing fuel tanks, avoiding the need for costly redesign. Service intervals are set at 500 hours as standard and Perkins provides comprehensive warranty cover for two years, with three years on major engine components. A low usage warranty package is also available.

Long-term power solution

The 1104D-E44TAG Electropak range has been designed to fully comply with stringent EPA Tier 3 emissions regulations, providing an emissions compliant power solution for the future.

Certified against the requirements of Tier 3 legislation for non-road mobile machinery, powered by constant speed engines (EPA 40 CFR Part 89 Tier 3)

Engine Speed (rev/min)	Type of Operation	Typical Generator Output (Net)		Engine Power			
		kVA	kWe	Gross		Net	
				kWm	bhp	kWm	bhp
1800	Prime Power	92.0	73.8	88.0	118.0	82.0	109.9
	Standby (maximum)	102.0	81.7	96.8	129.8	90.8	121.8

The above ratings represent the engine performance capabilities to conditions specified in ISO 8528/5. Derating may be required for conditions outside the test conditions; consult Perkins Engines Company Limited.

Generator powers are typical and are based on typical alternator efficiencies and a power factor. Fuel specification: Consult Perkins Engines Company Limited (various fuel specifications are available). Lubricating oil: multi-grade oil conforming to API-CH4/CI4 must be used.

Rating Definitions

Prime Power: Power available at variable load in lieu of a main power network. Overload of 10% is permitted for 1 hour in every 12 hours' operation.

Standby (maximum): Power available at variable load in the event of a main power network failure. No overload is permitted.

Photographs are for illustrative purposes only and may not reflect final specification.

All information in this document is substantially correct at time of printing and may be altered subsequently.

Publication No. PN1893/09/12 Produced in England ©2012 Perkins Engines Company Limited

Perkins®

THE HEART OF EVERY GREAT MACHINE

1100 Series 1104D-E44TAG1 Diesel Engine – Electropak

90.8 kW @ 1800 rev/min

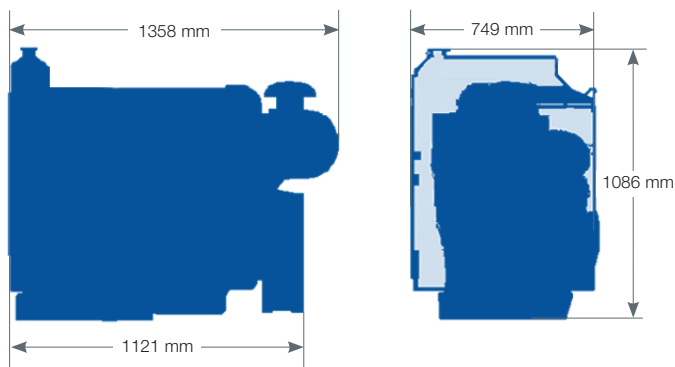
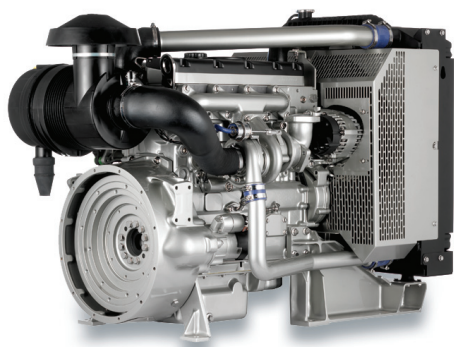

Standard Electropak specification

Air inlet

- Mounted air filter and turbocharger

Cooling system

- 22" belt-driven pusher fan and guards
- Radiator (incorporating air-to-air charge cooler)
- Water pump

Electric system

- 12 volt starter motor
- 12 volt, 65 amp alternator with DC output

Flywheel and housing

- High inertia flywheel to SAE J620 Size 10/11
- SAE3 flywheel housing

Fuel system

- Electronic governing (conforms to Class G3 ISO 8528-5)
- Fuel filter

Literature

- Users Handbook

Lubrication system

- Wet cast iron sump with filler and dipstick
- Oil filter

Start aids

- Glow plugs

Power Rating %	Fuel Consumption	
	1800 rev/min	
	g/kWh	l/hr
110	220.8	25.5
100	224.2	23.7
75	237.7	18.7
50	257.8	13.5

General data

Number of cylinders	4 in-line
Bore and stroke.....	105 mm x 127 mm
Displacement	4.41 litres
Aspiration	Turbocharged air-to-air chargecooled
Cycle.....	4 stroke
Combustion system.....	Direct injection
Compression ratio	16.2:1
Rotation.....	Anti-clockwise viewed on flywheel
Cooling system.....	Water-cooled
Total lubrication system capacity.....	8 litres
Total coolant capacity	17 litres
Dimensions – Length	1358 mm
Width	749 mm
Height	1086 mm
Dry weight	465 kg
Wet weight	474 kg

Final weight and dimensions will depend on completed specification

Photographs are for illustrative purposes only and may not reflect final specification.

All information in this document is substantially correct at time of printing and may be altered subsequently.
 Publication No. PN1893/09/12 Produced in England
 ©2012 Perkins Engines Company Limited

Perkins Engines Company Limited

Peterborough PE1 5FQ
 United Kingdom
 Telephone +44 (0)1733 583000
 Fax +44 (0)1733 582240

www.perkins.com



THE HEART OF EVERY GREAT MACHINE