

LGW 523 mpi

automotive

code 1.5302.711

Workshop Manual

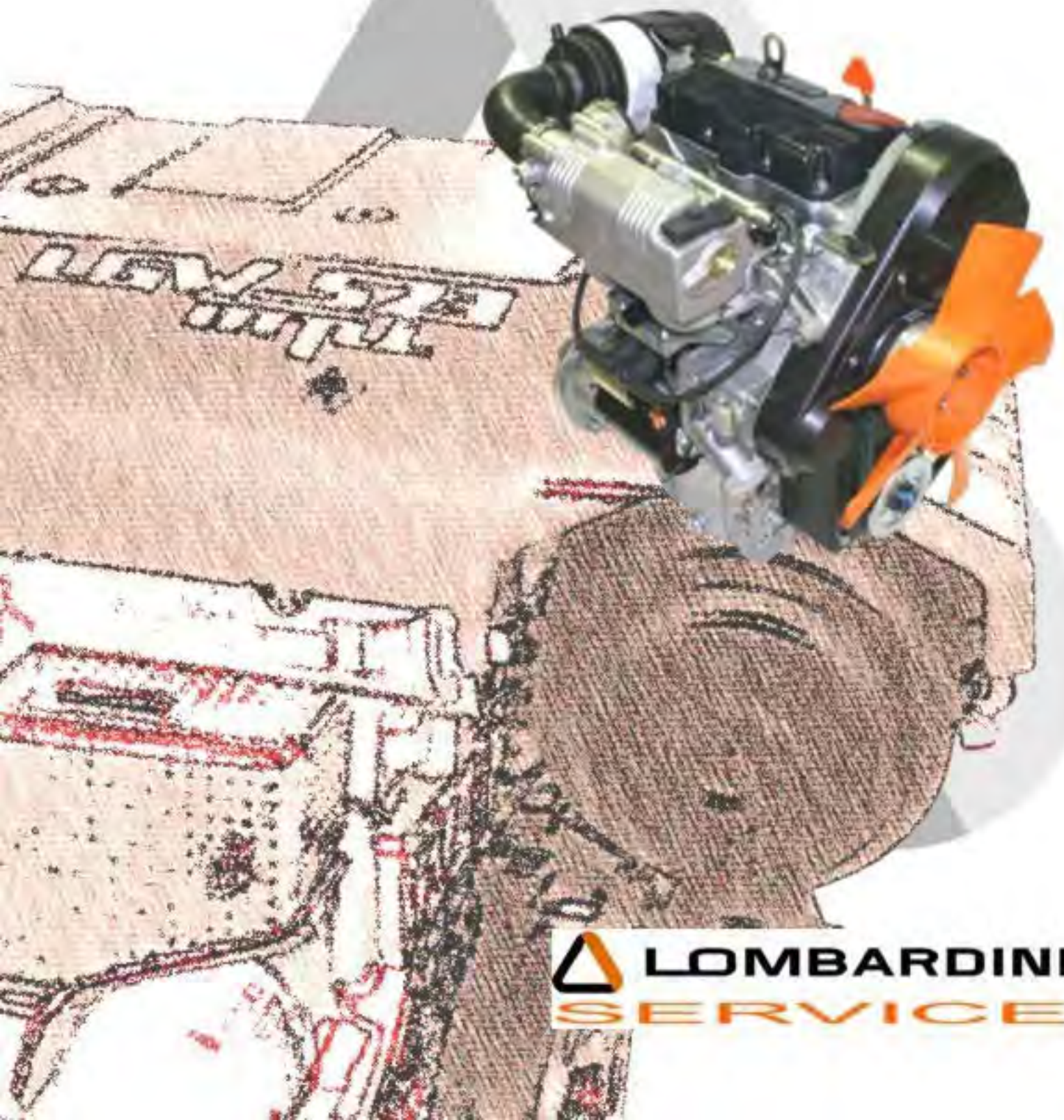

 **LOMBARDINI**
SERVICE

**REGISTRATION OF MODIFICATIONS TO THE DOCUMENT**

This document consists of 108 pages (sides -excluding the cover and title page). Each page is numbered in progressive order

from 050530.01 to 050530.108.

Any modifications to this document must be registered by the drafting body and approved by the head of the Quality Management System, by completing the following table.

Drafting body	Document code	Edition	Issue date	Review date	Replaced pages	Added pages	Eliminated pages
ATLO	1-5302-711	1°	26-04-2007				

1	GENERAL REMARKS AND SAFETY INFORMATION		
1.1	PURPOSE OF THE MANUAL	5	
1.2	USING THIS MANUAL	5	
1.3	MANUFACTURER AND ENGINE IDENTIFICATION	5	
1.4	GLOSSARY AND TERMINOLOGY	6	
1.5	WARRANTY CLAUSES	6	
1.6	GENERAL SAFETY REGULATIONS	6	
1.7	GENERAL SAFETY DURING OPERATION	6	
1.8	SAFETY AND ENVIRONMENTAL IMPACT	7	
1.9	PRECAUTIONS WHEN THE ENGINE IS INSTALLED ON THE VEHICLE	7	
1.10	PRECAUTIONS WHEN THE ENGINE IS ON THE ROTATING STAND	7	
2	TECHNICAL INFORMATION		
2.1	GENERAL DESCRIPTION OF THE ENGINE	9	
2.2	TECHNICAL SPECIFICATIONS	10	
2.3	PERFORMANCE CURVE DIAGRAM	12	
2.4	ALTERNATOR LOAD CURVE DIAGRAMS	13	
2.5	LUBRICANTS	14	
2.6	COOLANT	15	
2.7	FUEL SPECIFICATIONS	15	
2.8	ROUTINE MAINTENANCE OF LGW 523 MPI ENGINE	15	
2.9	OPERATING PRINCIPLE FOR LUBRICATION	16	
2.10	OPERATING PRINCIPLE FOR COOLING	16	
2.11	OPERATING PRINCIPLE FOR FUEL SUPPLY	17	
2.12	WIRING DIAGRAM	18	
2.13	ELECTRONIC ENGINE CONTROL WIRING DIAGRAM	20	
2.14	ELECTRICAL WIRING FOR ELECTRONIC ENGINE CONTROL	21	
2.15	FUEL SUPPLY SYSTEM	22	
2.15.1	Electric fuel supply pump	22	
2.15.2	Fuel filter	22	
2.15.3	Pressure regulator	22	
2.15.4	Prefilter	22	
2.15.5	Injector supply pipe	23	
2.15.6	Injectors	23	
2.15.7	Inertial switch	23	
2.16	ELECTRONIC ENGINE CONTROL SYSTEM	24	
2.16.1	Ignition coil	25	
2.16.2	Spark plug	25	
2.16.3	Lambda probe sensor	25	
2.16.4	Electronic control unit (E.C.U.)	26	
2.16.5	Control unit identification plate	26	
2.16.6	Speed sensor	26	
2.16.7	Air temperature sensor	27	
2.16.8	Absolute pressure sensor	27	
2.16.9	Water temperature sensor	27	
2.16.10	Throttle control sensor	28	
2.16.11	Throttle body	28	
2.17	INTAKE SYSTEM	29	
2.18	EXHAUST SYSTEM	29	
2.19	SPECIAL TOOLS AND EQUIPMENT FOR MAINTENANCE	30	
2.20	TIGHTENING TORQUE TABLES	30	
2.20.1	Table of tightening torques for standard screws (coarse thread)	30	
2.20.2	Table of tightening torques for standard screws (fine thread)	31	
2.20.3	Table of tightening torques for the main components	31	
2.21	TABLE OF SEALANTS	32	
3	MALFUNCTIONS		
3.1	TABLE OF LIKELY ANOMALIES AND THEIR SYMPTOMS	33	
4	STORING THE ENGINE		
4.1	HANDLING AND LIFTING	35	
4.2	ENGINE STORAGE (UNINSTALLED)	35	
4.3	ENGINE STORAGE (INSTALLED)	35	
4.4	PROTECTIVE TREATMENT	36	
4.5	PREPARING THE ENGINE FOR OPERATION AFTER PROTECTIVE TREATMENT	36	
5	REMOVING THE ASSEMBLIES		
5.1	RECOMMENDATIONS FOR REMOVING THE ASSEMBLIES	37	
5.2	REMOVING THE EXHAUST AND INTAKE MANIFOLDS	37	
5.2.1	Disassembling the intake manifold	37	
5.2.2	Disassembling the air flow sensors	40	
5.2.3	Disassembling the exhaust manifold	40	
5.3	REMOVING THE COOLING FAN BELT DRIVE	41	
5.3.1	Disassembling the cooling fan belt (with external alternator)	42	
5.3.2	Disassembling the cooling fan belt (with internal alternator)	42	
5.4	REMOVING THE TIMING BELT DRIVE	43	
5.4.1	Disassembling the timing belt guard	43	
5.4.2	Timing belt and gears	43	
5.4.3	Removing the speed sensor	44	
5.4.4	Disassembling the synchronous timing belt	44	
5.4.5	Sliding pulley and belt tightener	44	
5.4.6	Disassembling the synchronous timing belt pulleys (camshaft and crankshaft)	45	
5.4.7	Disassembling the coolant circulation pump	45	
5.4.8	Disassembling the pump scroll	46	
5.5	REMOVING THE CYLINDER HEAD AND COMPONENTS	46	
5.5.1	Disassembling the spark plug	46	
5.5.2	Disassembling the rocker arm cover	47	
5.5.3	Disassembling the rocker arm assembly	47	
5.5.4	Disassembling the injectors	48	
5.5.5	Disassembling the camshaft	50	
5.5.6	Disassembling the thermostatic valve body	50	
5.5.7	Removing the cylinder head	51	
5.6	DISASSEMBLING THE VALVES	51	
5.7	REMOVING THE CRANK GEAR AND CRANKCASE	52	
5.7.1	Disassembling the flywheel	52	
5.7.2	Disassembling the oil pump	52	
5.7.3	Disassembling the crankcase and crankshaft	53	
5.7.4	Disassembling the connecting rod and piston	54	
5.8	DISASSEMBLING THE PISTON	54	

6 OVERHAULS AND TUNING

6.1	RECOMMENDATIONS FOR OVERHAULS AND TUNING	57
6.1.1	Shaft seals	57
6.1.2	O-rings	57
6.1.3	Bearings	57
6.2	OVERHAULING THE CRANK GEARS AND CRANKCASE	57
6.2.1	Overhauling cylinders and pistons	57
6.2.2	Dimensional check and overhaul of cylinders	58
6.2.3	Dimensional check and overhaul of pistons	58
6.2.4	Dimensional check of sealing rings	59
6.2.5	Dimensional check and overhaul of crankshaft ..	60
6.2.6	Dimensional check and overhaul of connecting rods	61
6.2.7	Checking parallelism of the connecting rod axes	61
6.2.8	Checking and overhauling the oil pump	62
6.2.9	Overhauling the decanting device	63
6.3	OVERHAULING THE CYLINDER HEAD AND COMPONENTS	63
6.3.1	Checking and overhauling the cylinder head	63
6.3.2	Checking and overhauling the valves	64
6.3.3	Checking and overhauling the rocker arm pin	65
6.3.4	Hydraulic tappets	66
6.3.5	Checking and replacing the camshaft	68
6.4	DIAGRAM OF TIMING BELT RATES	69
6.5	CHECKING THE SPARK PLUG	69
6.6	REPLACING THE FLYWHEEL RING GEAR	70

7 INSTALLATION OF ASSEMBLIES

7.1	RECOMMENDATIONS FOR INSTALLING ASSEMBLIES	71
7.2	INSTALLING VALVES	71
7.2.1	Assembling the valves	71
7.3	PREASSEMBLY OF SEALING RINGS - PISTONS	72
7.4	PRE-ASSEMBLY OF CONNECTING RODS – PISTONS	73
7.5	INSTALLATION OF CRANK GEAR AND CRANKCASE	73
7.5.1	Installing piston/connecting rod - engine block ..	73
7.5.2	Assembling the crankshaft	74
7.5.3	Assembling the crankcase	75
7.5.4	Checking crankshaft axial clearance	75
7.5.5	Assembling the crankshaft flange (flywheel side)	76
7.5.6	Installing the pump scroll	76
7.5.7	Installing the coolant circulation pump	77
7.5.8	Assembling the oil pump	77
7.5.9	Assembling the flywheel	78
7.5.10	Determining clearance volume	79
7.6	INSTALLATION OF CYLINDER HEAD AND COMPONENTS	80
7.6.1	Assembling the cylinder head	80
7.6.2	Assembling the camshaft	80
7.6.3	Installing the camshaft support and timing belt pulley	81
7.6.4	Installing the rocker arm assembly	81
7.6.5	Installing the rocker arm cover	81
7.6.6	Installing the spark plug	82
7.6.7	Installing the injectors	82

7.6.8	Installing the thermostatic valve body	83
7.7	INSTALLATION OF THE TIMING BELT DRIVE	84
7.7.1	Assembling the phase sensor	84
7.7.2	Assembling the timing belt pulleys (camshaft and crankshaft)	85
7.7.3	Adjusting the phase sensor	85
7.7.4	Assembling the synchronous timing belt	85
7.7.5	Assembling the timing belt guard	86
7.8	INSTALLATION OF THE COOLING FAN BELT DRIVE	87
7.8.1	Assembling the cooling fan belt drive pulleys	87
7.8.2	Assembling the cooling fan belt (with internal alternator)	88
7.8.3	Assembling the cooling fan belt (with external alternator)	89
7.9	INSTALLATION OF THE EXHAUST AND INTAKE MANIFOLDS	90
7.9.1	Assembling the throttle and sensors	90
7.9.2	Assembling the intake manifold	90
7.9.3	Assembling the exhaust manifold	92

8 VEHICLE CONTROLS

8.1	VEHICLE CONTROLS	95
8.1.1	Preliminary checks	95
8.2	COMPONENTS LAYOUT INSIDE THE ENGINE CASE	95
8.2.1	Petrol pressure check	96
8.2.2	Injector check	96
8.2.3	Adjusting the accelerator cable	97
8.3	DIAGNOSTIC	98
8.3.1	Using the diagnostic procedures	98
8.3.2	Technical features	98
8.3.3	Total view of the tool	98
8.3.4	Accessories	99
8.3.5	Autodiagnostic software	99
8.4	PRELIMINARY OPERATIONS	100
8.4.1	Connecting to the vehicle	100
8.4.2	Vehicle and system selection	100
8.5	AVAILABLE FUNCTIONS FOR DIAGNOSTIC ...	102
8.5.1	Autodiagnostic	102
8.5.2	Detecting faults	102
8.5.3	Menu bar	103
8.5.4	Important to be pointed out before starting	103
8.6	ERRORS	104
8.7	CONSTRUCTION PARAMETERS	105

1.1 PURPOSE OF THE MANUAL

- This manual was written by the manufacturer to provide technical and operating information to authorised **LOMBARDINI** after-sales service centres to carry out assembly, disassembly, overhauling, replacement and tuning operations.
- This information is provided by the manufacturer in its own language (Italian) and may be translated into other languages to satisfy legislative and/or commercial requirements.
- As well as employing good operating techniques and observing the right timing for operations, operators must read the information very carefully and comply with it scrupulously.
- Time spent reading this information will help to prevent health and safety risks and financial damage. Written information is accompanied by illustrations in order to facilitate your understanding of every step of the operating phases.

- Important remarks and features of the text are highlighted using symbols, which are explained below.



Danger – Attention

This indicates situations of grave danger which, if ignored, may seriously threaten the health and safety of individuals.



Caution – Warning

This indicates that it is necessary to take proper precautions to prevent any risk to the health and safety of individuals and avoid financial damage.



Important

This indicates particularly important technical information that should not be ignored.

1.2 USING THIS MANUAL

- This manual is divided into several chapters.
- The first chapter gives general information and details about safety (purpose of the manual, safety, etc.).
- The second, third and fourth chapters provide general technical information (technical specifications, diagrams, tightening torques, malfunctions, etc.).
- The fifth, sixth, seventh and eighth chapters describe the most important operating procedures (removal, overhaul and tuning, installation, replacements, etc.).

- This final section, which is reserved specifically for **LOMBARDINI** after-sales service centres, has been prepared with technical and practical considerations in mind.
- However, the actual sequence of operations that **LOMBARDINI** service centres use may in some cases be different from the ones described in this manual. For this reason, readers should refer to the index to find their topic of interest quickly.

1.3 MANUFACTURER AND ENGINE IDENTIFICATION

The identification plate shown in the figure can be found directly on the engine. It contains the model, engine identity and all information needed to operate safely.

- A) Manufacturer's identity
- B) Engine type
- C) Engine serial number
- D) Maximum operating speed
- E) Number of the customer version (form K)

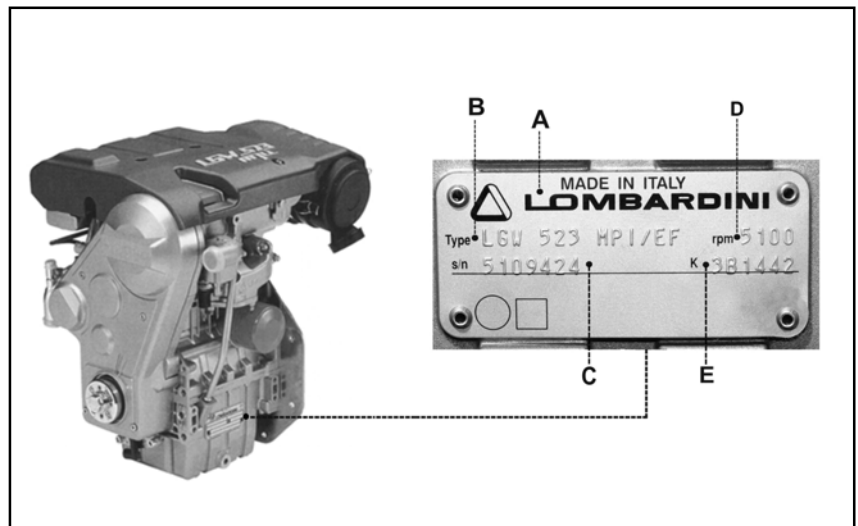

1.4 GLOSSARY AND TERMINOLOGY

For clarity, here are the definitions of a number of terms used recurrently in the manual.

- **Cylinder number one:** first piston «viewed from the flywheel side of the engine».
- **Rotation direction:** clockwise or anticlockwise «viewed from the timing belt side of the engine».

1.5 WARRANTY CLAUSES

LOMBARDINI issues a warranty certificate for each engine giving details of all relevant general terms.

1.6 GENERAL SAFETY REGULATIONS

- In designing and building its product, the manufacturer has paid particular attention to those aspects that pose a risk to the health and safety of persons handling the engine. In addition to legislative requirements, all «rules for good technical construction» have been applied.
- The purpose of this information is to invite operators to pay particular attention in order to prevent any form of risk. Caution is always the best policy. Safety is also the responsibility of all operators who handle the engine.
- All persons carrying out work on the engine at any point in its life, must possess precise technical qualifications and skills, as well as recognised experience gained in the specific sector. Non-compliance with these requirements may cause damage to the health and safety of individuals.
- Do not tamper with, sidestep, eliminate or bypass the installed safety devices. Non-compliance with this requirement may be hazardous to the health and safety of individuals.

1.7 GENERAL SAFETY DURING OPERATING PHASES

- The procedures contained in this manual have been tested and selected by the manufacturer's technical experts, and hence are to be recognised as authorised operating methods.
- A number of procedures must be carried out with the aid of equipment and tools that simplify and improve the timing of operations.
- Some of these tools are normal workshop equipment, while others are specific instruments that have been constructed by the engine manufacturer.
- All tools must be in good working condition so that engine components are not damaged and that operations are carried out properly and safely. It is important to wear the personal safety devices prescribed by work safety laws and also by the standards of this manual.
- Holes must be lined up methodically and with the aid of suitable equipment. Do not use your fingers to carry out this operation to avoid the risk of amputation.
- Some phases may require the assistance of more than one operator. If so, it is important to inform and train them regarding the type of activity they will be performing in order to prevent risks to the health and safety of all persons involved.
- Do not use flammable liquids (petrol, diesel, etc.) to degrease or wash components. Use special products.
- Keep flames away from the engine to avoid the risk of fire.
- Replace worn or damaged parts exclusively with original **LOMBARDINI** spare parts. This will contribute to ensuring better performance and longer product life.
- Use the oils and greases recommended by the manufacturer. Do not mix different brands or combine oils with different characteristics.
- Use a torque wrench to tighten the main fixing points of engine components. Comply with the tightening torques indicated by the manufacturer.
- Discontinue use of the engine if any irregularities arise, particularly in the case of unusual vibrations.
- The engine has been designed and built to satisfy all the operating conditions described by the manufacturer.
- Do not tamper with any devices to alter the level of performance guaranteed by the manufacturer.

1.8 SAFETY AND ENVIRONMENTAL IMPACT

Every organisation has a duty to implement procedures to identify, assess and monitor the influence of its own activities (products, services, etc.) on the environment. Procedures for identifying the extent of the impact on the environment must consider the following factors:

- Liquid waste
- Waste management
- Soil contamination
- Atmospheric emissions
- Use of raw materials and natural resources
- Regulations and directives regarding environmental impact

In order to minimise the impact on the environment, the manufacturer now provides a number of indications to be followed by all persons handling the engine, for any reason, during its expected lifetime.

- All packaging components must be disposed of in accordance with the laws of the country in which disposal is taking place.
- Keep the fuel and engine control systems and the exhaust pipes in efficient working order to limit environmental and noise pollution.
- When discontinuing use of the engine, select all components according to their chemical characteristics and dispose of them separately.

1.9 PRECAUTIONS WHEN THE ENGINE IS INSTALLED ON THE VEHICLE

- All operations, except where expressly stated otherwise, must be carried out when the engine is not running and has cooled sufficiently to avoid the risk of burns.
- Do not keep the engine running in areas that are closed and inadequately ventilated. Take all necessary precautions to prevent a build up of exhaust fumes.

1.10 PRECAUTIONS WHEN THE ENGINE IS ON THE ROTATING STAND

- Before removing the engine from the vehicle on which it is installed, disconnect the electric current, the fuel supply, coolant and all connections including mechanical ones.
- To lift the engine, attach the lifting device at the points (eyebolts) specified by the manufacturer.
- Close all engine openings carefully (exhaust, intake, etc.) wash the outside and dry with a jet of compressed air.
- Anchor the engine to the rotating stand to facilitate all operations.

Note: the engine may also be placed on the workbench, depending on the type of work to be carried out.

2.1 GENERAL DESCRIPTION OF THE ENGINE

Main components

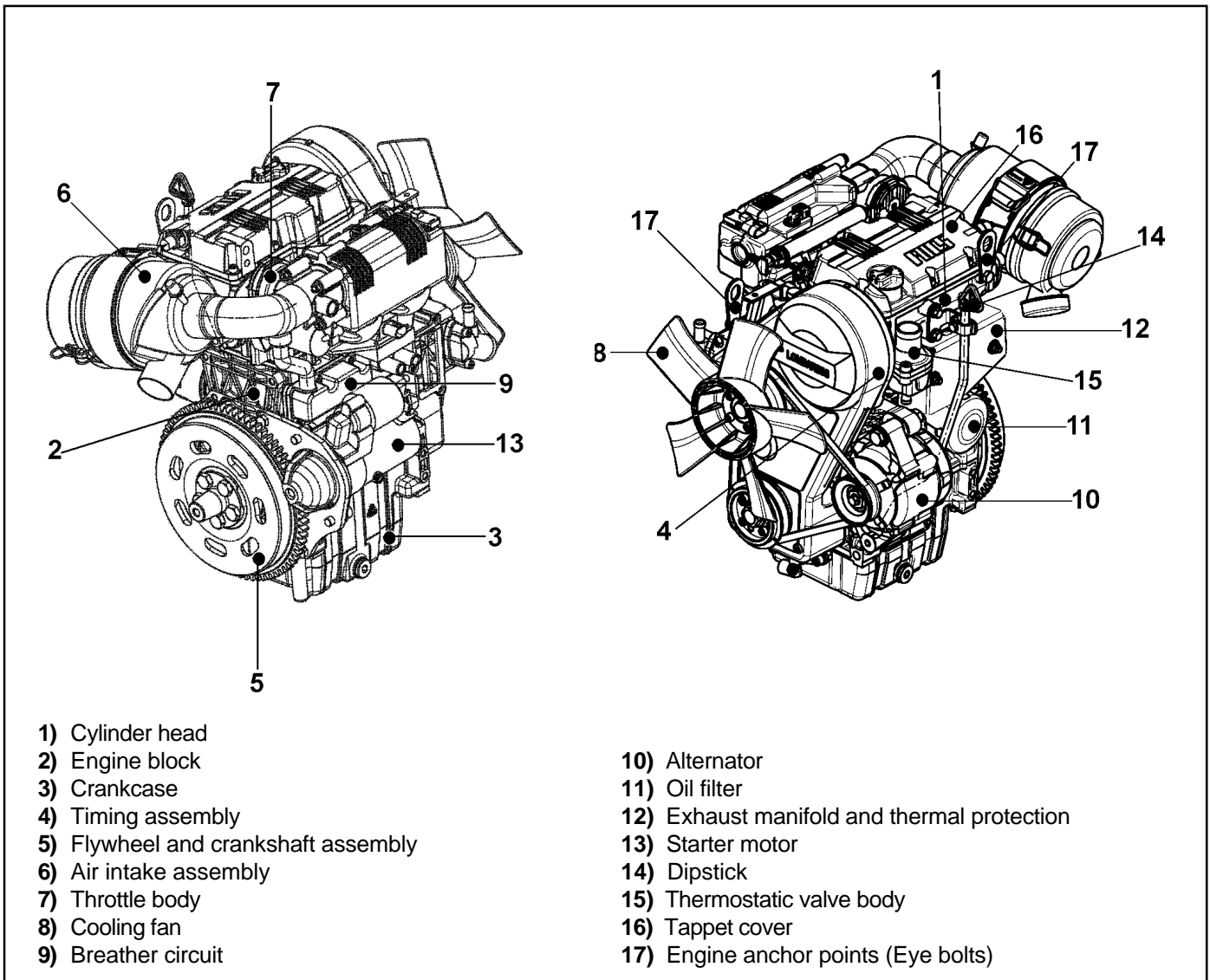

Description

- Four-stroke petrol engine, two in-line cylinders
- Cylinder block and head in aluminium alloy.
- Timing system with two valves per cylinder regulated by overhead camshaft driven by toothed belt, hydraulic tappets for automatic valve clearance adjustment.
- Timed sequential indirect multipoint fuel injection, with motorised drive-by-wire throttle and Lambda exhaust probe. Integrated injection and ignition control.
- Forced lubrication by crankshaft-driven oil pump.
- Cooling by forced liquid circulation.

Approval

- Able to satisfy pollution limits set by 2002/51/EC for vehicles belonging to the category of «quadricycles».

2.2. TECHNICAL SPECIFICATIONS

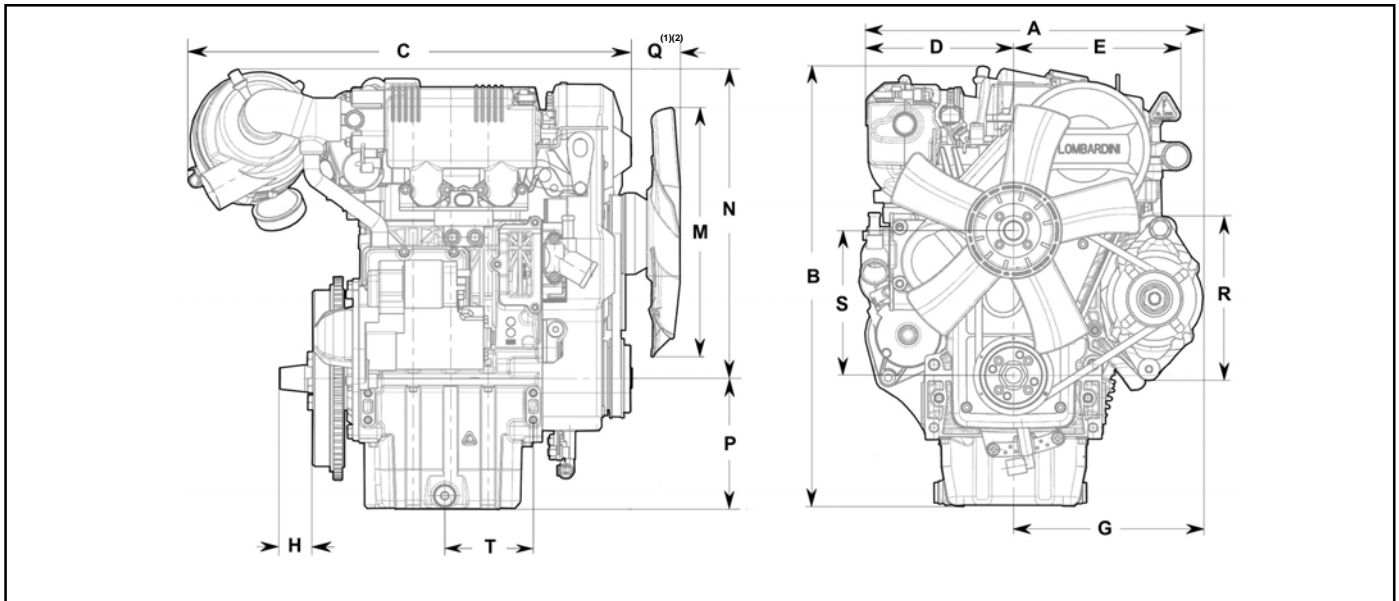
DIMENSIONS (mm)

A	372,9	D	163,5	H	37	P	145	R	182
B	484,2	E	180,1	M	280	Q	45,5 (1)	S	160
C	480,7	G	209,4	N	339,2		58 (2)	T	91,5

(1) with intake fan

(2) with exhaust fan

GENERAL DETAILS

Operating cycle	Four-stroke petrol	
Cylinders	n°	2 in line
Bore x stroke	mm	72x62
Displacements	cm ³	505
Compression rate	10,7:1	
Intake	Dry air filter	
Cooling	Liquid	
Crankshaft rotation	Clockwise (from timing system side)	
Combustion sequence	1:2	
Timing system	Synchronous toothed belt	
Valves	n°	2 per cylinder
Shaft	overhead camshaft	
Tappets	hydraulic	
Fuel injection	indirect sequential multipoint	
Dry weight of engine	Kg	52
Volume of air flow (at 5,000 RPM)	l/min	910
Volume of cooling air (at 5,000 RPM)	m ³ /min	36
POWER AND TORQUE		
Maximum operating speed	RPM	5500
Max. power (N 80/1269/EEC - ISO 1585 - DIN 7020)	kW	15 *
Maximum torque (at 2150 RPM)	Nm	34
Axial load allowed on crankshaft	Kg	300

* Self-limiting power for quadricycle applications.

FUEL SUPPLY CIRCUIT		
Fuel type	Unleaded petrol min. 95 RON	
Fuel supply	Electric pump	
Fuel filter	in line	
<i>Filter capacity</i>	µm	8÷10
Circuit pressure	bar	3,5
LUBRICATION CIRCUIT		
Type of lubrication	Completely forced	
Circuit supply	Trochoid pump	
Maximum oil quantity	including filter (l)	1,3
Maximum oil quantity	excluding filter (l)	1,2
Oil pressure at minimum speed (with oil temperature of 120°C)	no lower than 1 bar	
Oil filter cartridge		
<i>Maximum operating pressure</i>	bar	7
<i>Maximum combustion pressure</i>	bar	20
<i>Filter capacity</i>	µm	15
<i>By-pass valve setting</i>	bar	1,5÷1,7
<i>Filtering surface</i>	cm ²	730
COOLING CIRCUIT		
Coolant	50% water - 50% liquid anti-freeze liquid	
Thermostatic valve		
<i>Opening temperature</i>	°C	78°±82°
<i>Stroke at 94°C</i>	mm	7
<i>Liquid return</i>	l/h	30÷80
ELECTRICAL SYSTEM		
Nominal voltage	V	12
Alternator (nominal voltage)	V	14
Internal/external alternator (nominal current) (see «Alternator load curve diagrams»)	A	40
Starter motor power	kW	1,1
Oil pressure switch		
<i>Operating pressure bars</i>	bar	0,45÷0,75
Coolant temperature monitoring sensor		
<i>Electrical circuit</i>	Unipolar system	
<i>Supply voltage</i>	V	6÷24
<i>Absorbed power</i>	W	3
<i>Closed circuit temperature</i>	°C	97°÷103°

2.3 PERFORMANCE DIAGRAM

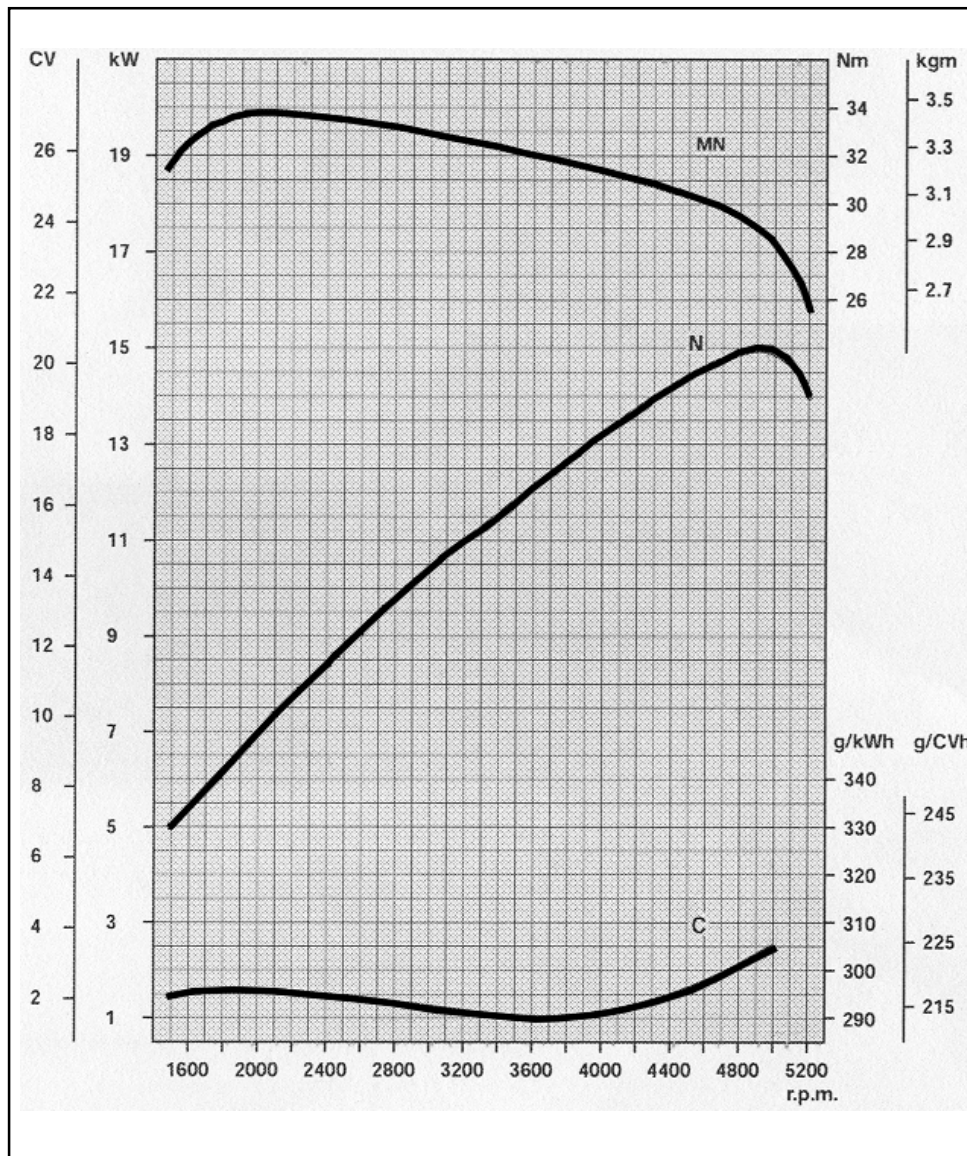

Legend

N* (80/1269/EEC-ISO 1585) = Power curve. Automotive power: discontinuous services at variable RPM and load.

MN* = Torque curve

C* = specific consumption curve

* The above curves are approximate since they depend on the intake and exhaust systems in use and on engine mapping

The above power levels refer to the engine equipped with air filter, muffler, fully broken-in suction fan, and ambient conditions of 20°C and 1 bar.

The maximum power is guaranteed with a tolerance of 5%.

These power rates are reduced by approx. 1% every 100m of altitude and by 2% for every 5°C exceeding 25°C.

Note:

Please contact Lombardini for power, torque, and specific consumption curves at different speeds from the above.



Caution – Warning

Please remember that any variation in the intake or exhaust system during the application phase of LGW 523 engines involves a variation in fuel.

Optimisation must be carried out beforehand at Lombardini testing centres.

Non-approval by Lombardini for any modifications releases the company from any damages incurred by the engine.

2.4 ALTERNATOR LOAD CURVE DIAGRAMS

Reading taken after heat stabilisation at 25°C and constant voltage 14V.

External 40A alternator load curve diagram

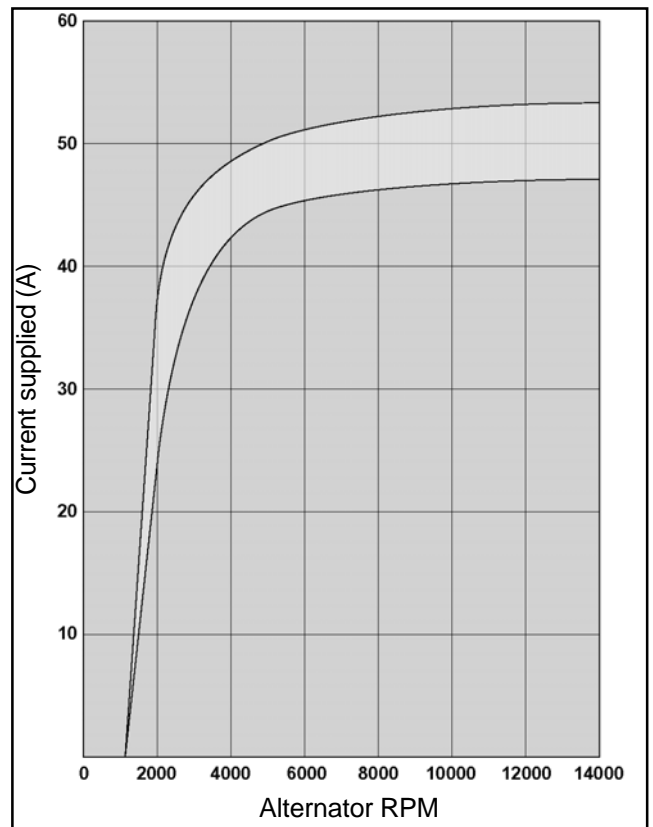

Internal 30A alternator load curve diagram

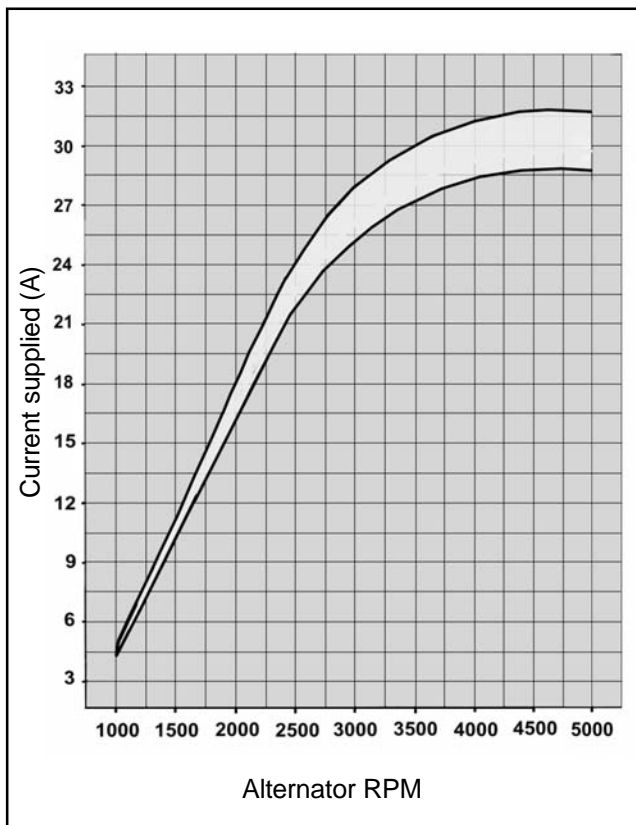

Internal 40A alternator load curve diagram

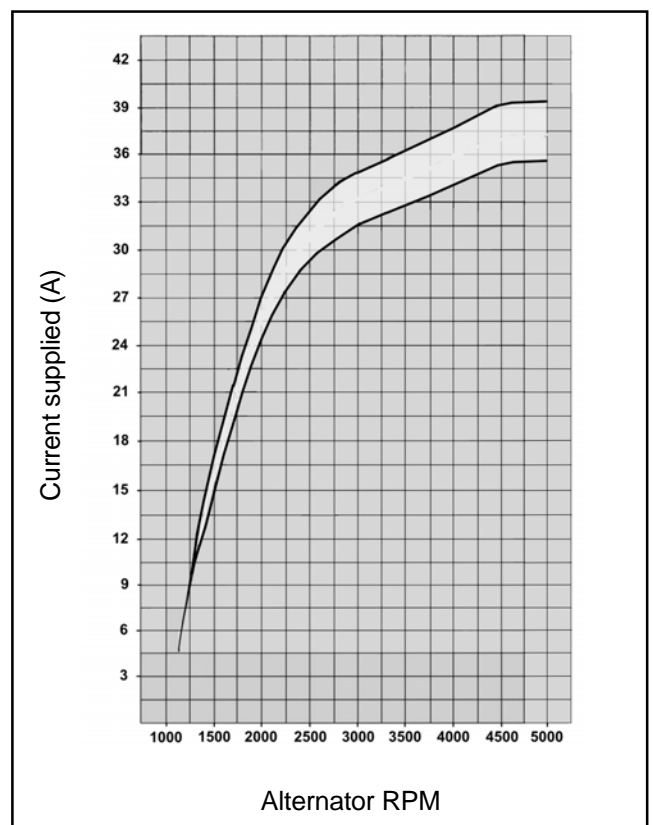

Reading taken after heat stabilisation at 20°C and constant voltage 12.5V.

* The alternator turns at the same rate as the engine.

2.5 LUBRICANTS

SAE classification

In the SAE classification oils are identified according to viscosity without considering any other qualitative characteristic.

The first number refers to the viscosity when cold, for use during winter (W= winter), while the second number is for viscosity at high temperatures. The criteria for choosing an oil must include the minimum ambient temperature to which the engine is to be exposed during the winter and the maximum temperature during operation in the summer.

Monograde oils are generally used when the operating temperature varies little.

Multigrade oils are less sensitive to temperature variations.

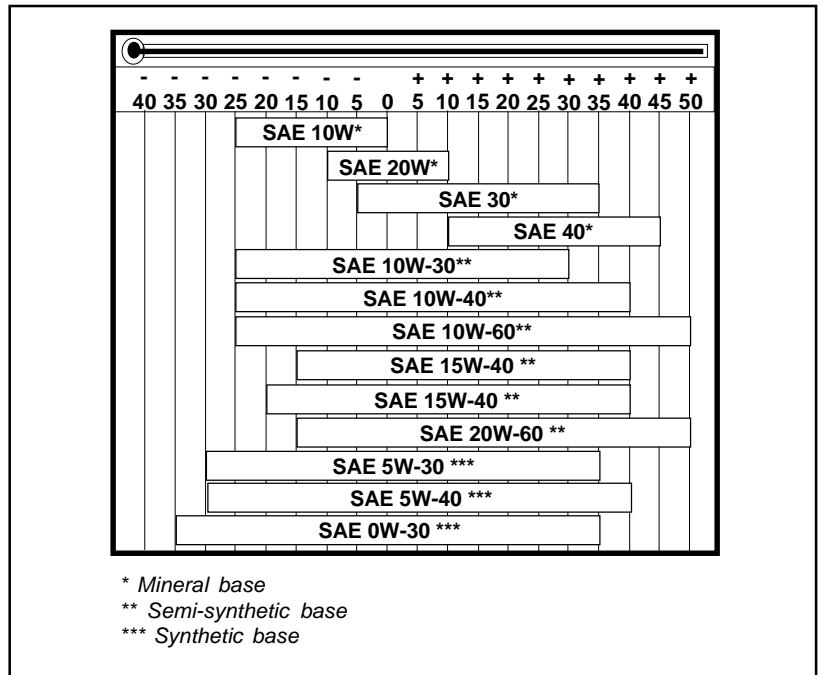

API/MIL Sequences

	DIESEL										PETROL									
API	CH-4	CG-4	CF-4	CF-2	CF	CE	CD	CC	CB	CA	SA	SB	SC	SD	SE	SF	SG	SH	SJ	SL
MIL						L - 2104 D / E					L - 46152 B / C / D / E									
	CORRENTI - CURRENT										OBSOLETE - OBSOLETE									

Key to abbreviations

- A.P.I. : (American Petroleum Institute)
- MIL : USA military specifications for engine oils issued for logistics reasons
- ACEA : European Automobile Manufacturers Association

ACEA Standards – ACEA sequences

PETROL

- A1 = Low-viscosity, for friction reduction
- A2 = Standard
- A3 = High performance

LIGHT DIESELS

- B1 = Low-viscosity, for friction reduction
- B2 = Standard
- B3 = High performance (indirect injection)
- B4 = High quality (direct injection)

HEAVY DIESELS

- E1 = Obsolete
- E2 = Standard
- E3 = Heavy conditions (Euro 1 - Euro 2 engines)
- E4 = Heavy conditions (Euro 1 - Euro 2 - Euro 3 engines)
- E5 = High performance in heavy conditions (Euro 1 - Euro 2 - Euro 3 engines)

Recommended oil

Description	Oil type	Oil characteristics
Engine oil	Agip SINT 2000 5W40	API SJ/CF ACEA A3-96 B3-96 MIL-L-4615 D/E

Engine oil capacity

Oil volume at max. level (including oil filter)	Litres	1,3
Oil volume at max. level (without filter)	Litres	1,2

2.6 COOLANT

The use of anti-freeze protection liquid (e.g. AGIP ANTIFREEZE) is recommended mixed with water, preferably decalcified.

The freezing point of the cooling mixture depends on the product concentration in water:

at -15°C (30%), at -20°C (35%), at -25°C (40%), at -30°C (45%), at -35°C (50%).

It is therefore recommended to use a 50% diluted mixture which guarantees a certain degree of overall protection. As well as lowering the freezing point, the permanent liquid also raises the boiling point.

2.7 FUEL SPECIFICATIONS

Unleaded petrol min. 95 RON.

2.8 ROUTINE ENGINE MAINTENANCE – LGW 523 MPI



Non-compliance with the operations described in the table may lead to technical damage to the engine and vehicle, and furthermore, releases the manufacturer from the warranty obligations.

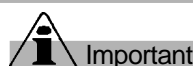

Even if the set mileage has not been reached, the following must nevertheless be replaced:

- engine oil after one year
- coolant after two years
- fan/alternator belt after four years
- timing belt after four years

PROCEDURE	DETAIL	REGULARITY per 1000km										
		1	10	20	30	40	50	60	70	80	90	100
CHECK	ENGINE OIL	EVERY 2.500 Km										
	COOLANT LEVEL	EVERY 2.500 Km										
	COOLING SYSTEM											
	ALTERNATOR/FAN BELT TENSION											
	AIR FILTER											
	FUEL PIPES AND UNIONS											
	EXHAUST SYSTEM											
CHANGE	ENGINE OIL											
	OIL FILTER											
	FUEL FILTER											
	AIR FILTER CARTRIDGE											
	ALTERNATOR/FAN BELT											
	SPARK PLUGS											
	COOLANT											
	TIMING BELT(*)											

(*) Replace the timing belt whenever it is removed, even if has not completed its scheduled motion time. Maintain the same maintenance intervals above 100,000 km.

2.9 OPERATING PRINCIPLE FOR LUBRICATION

Réf.	Description
1	Pressure switch
2	Rocker arm pin
3	Connecting rod big end pin
4	Oil filter cartridge
5	Main journal
6	Oil drain plug
7	Dipstick
8	Breather pipe
9	Oil refill plug
10	Camshaft
11	Oil pressure adjustment valve
12	Oil pump
13	Crankshaft
14	Oil suction filter
15	Hydraulic tappet

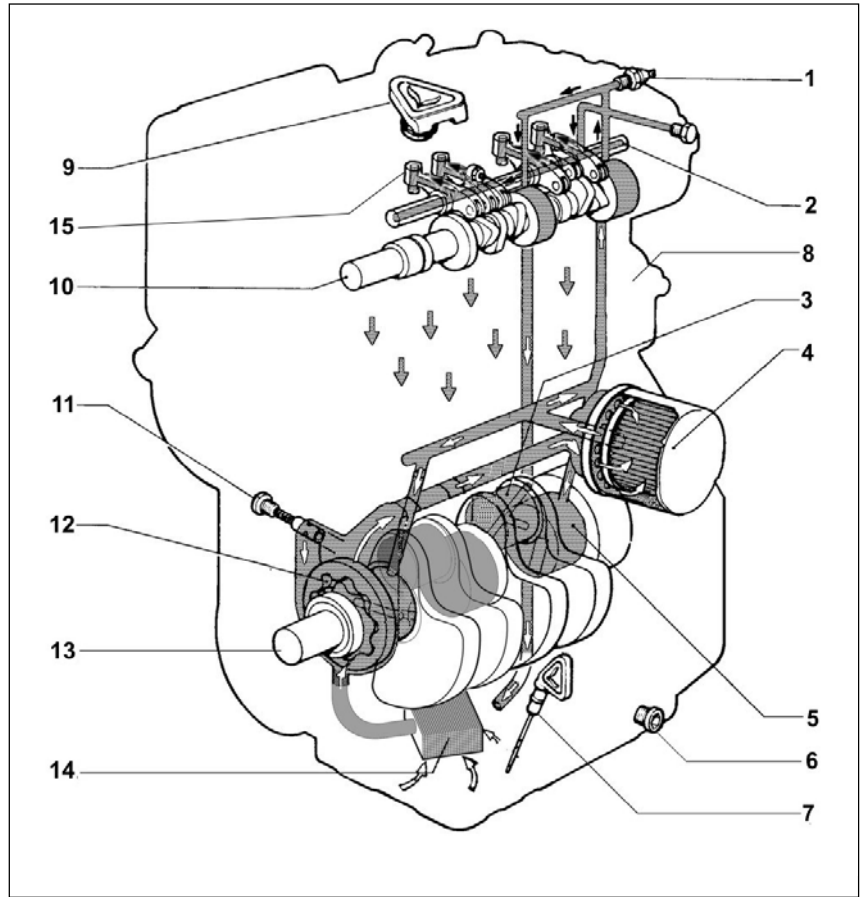

2.10 OPERATING PRINCIPLE FOR COOLING

Réf.	Description
1	Coolant refill plug
2	Compensation tank
3	Thermostatic valve
4	Cylinder block
5	Liquid temperature monitoring thermostat
6	Circulation pump
7	Fan
8	Radiator

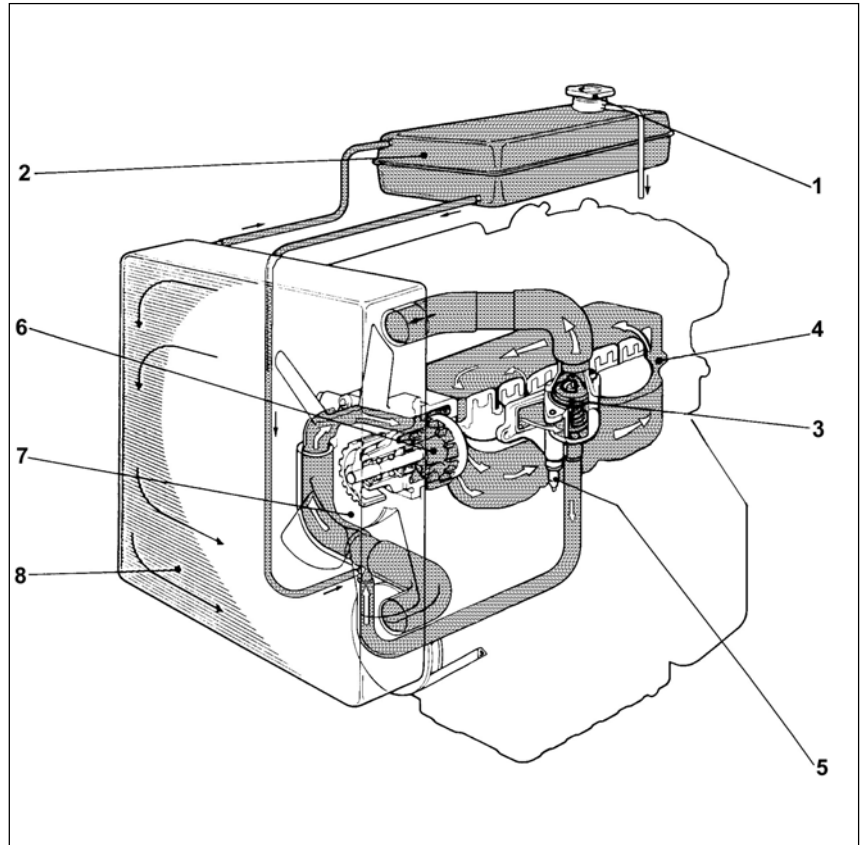

2.11 OPERATING PRINCIPLE FOR FUEL SUPPLY

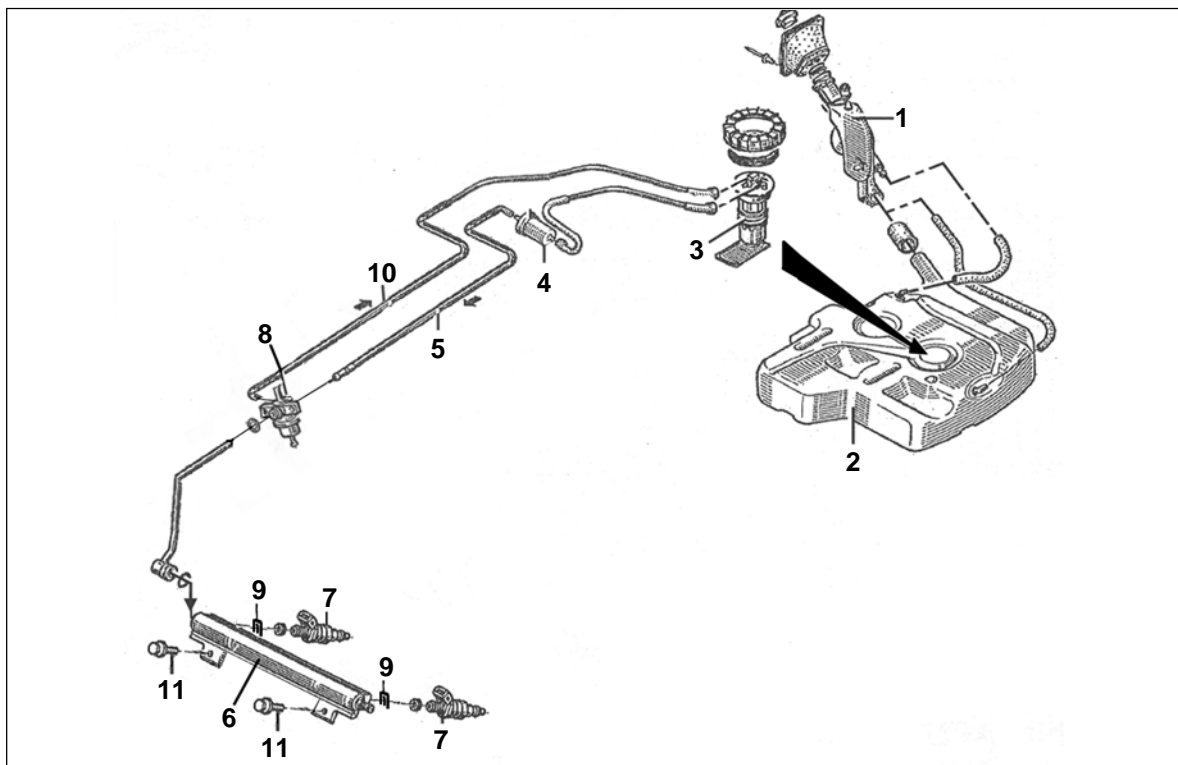

Réf.	Description
1	Refill pipe
2	Tank
3	Dipstick/pump assembly
4	Filter
5	Supply duct
6	Injector supply pipe
7	Injector
8	Pressure regulator
9	Injector check spring
10	Return pipe from the pressure regulator
11	Fastening screws of the supply pipe

2.12 WIRING DIAGRAM

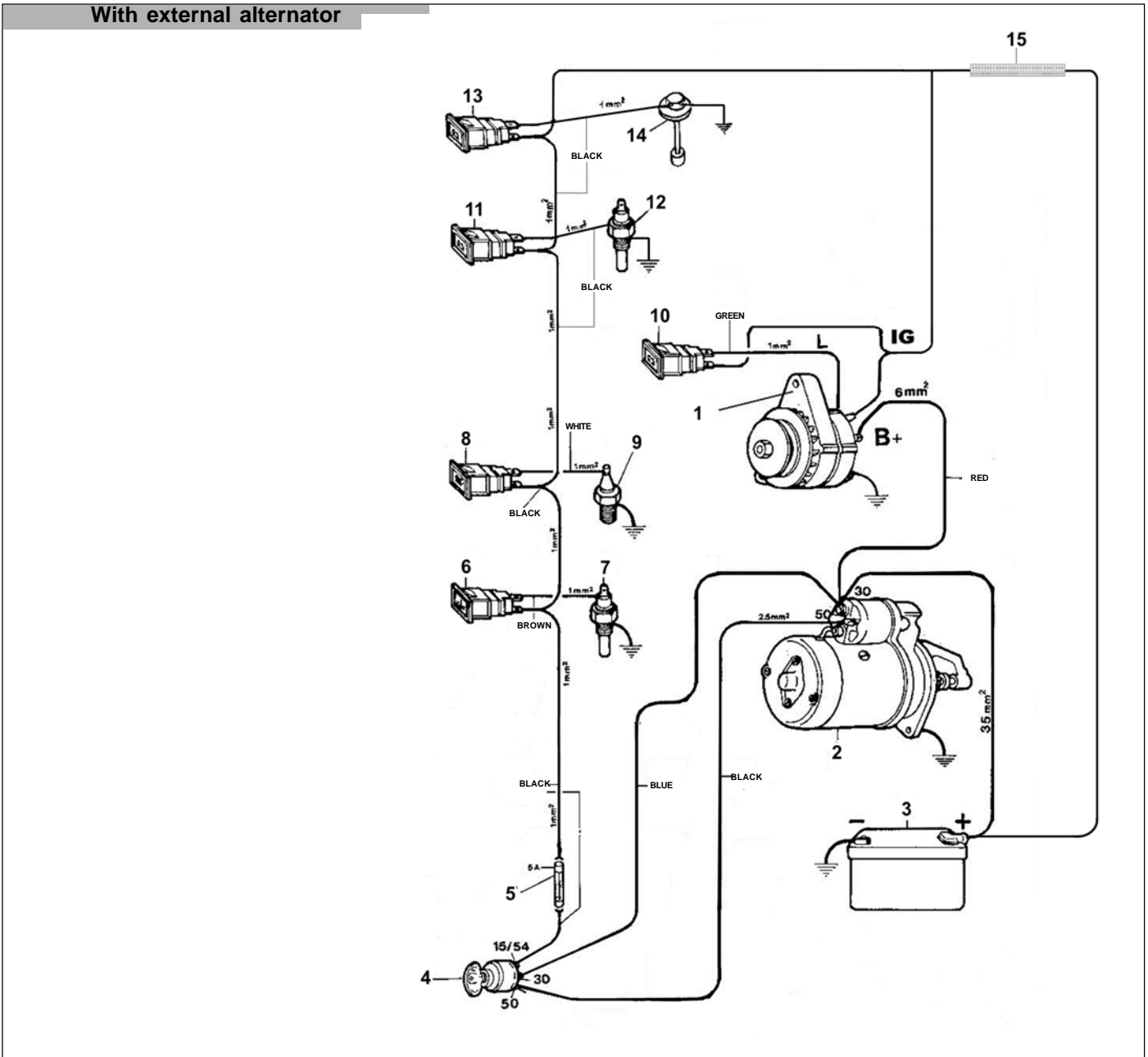

Réf.	Description
1	40A Alternator
2	Starter motor
3	Battery (44Ah-210A-DIN recommended)
4	Ignition switch
5	5A fuse
6	Coolant temperature indicator light
7	Coolant thermostat indicator light
8	Engine oil pressure indicator light
9	Oil pressure switch
10	Battery load indicator light
11	Coolant thermometer
12	Coolant thermometer sensor

Rif.	Description
13	Fuel level light
14	Fuel level indicator
15	Vehicle/engine interface connector

With internal alternator

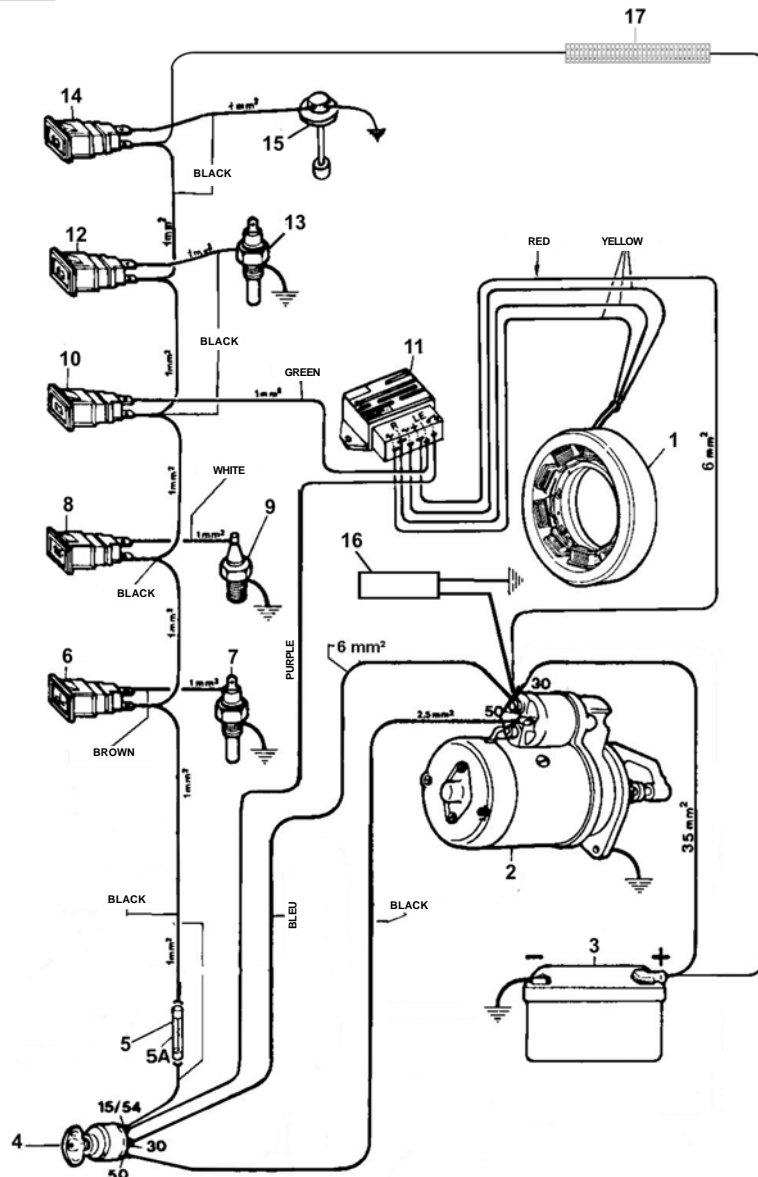

Réf.	Description
1	40A/30A Alternator
2	Starter motor
3	Battery (44Ah-210A-DIN recommended)
4	Ignition switch
5	5A fuse
6	Coolant temperature indicator light
7	Coolant thermostat indicator light
8	Engine oil pressure indicator light
9	Oil pressure switch
10	Battery load indicator light
11	Voltage regulator
12	Coolant thermometer

Rif.	Description
13	Coolant temperature sensor
14	Fuel level light
15	Fuel level indicator
16	25 V - 10000 iF condenser
17	Vehicle/engine interface connector

2.13 ELECTRONIC ENGINE CONTROL WIRING DIAGRAM

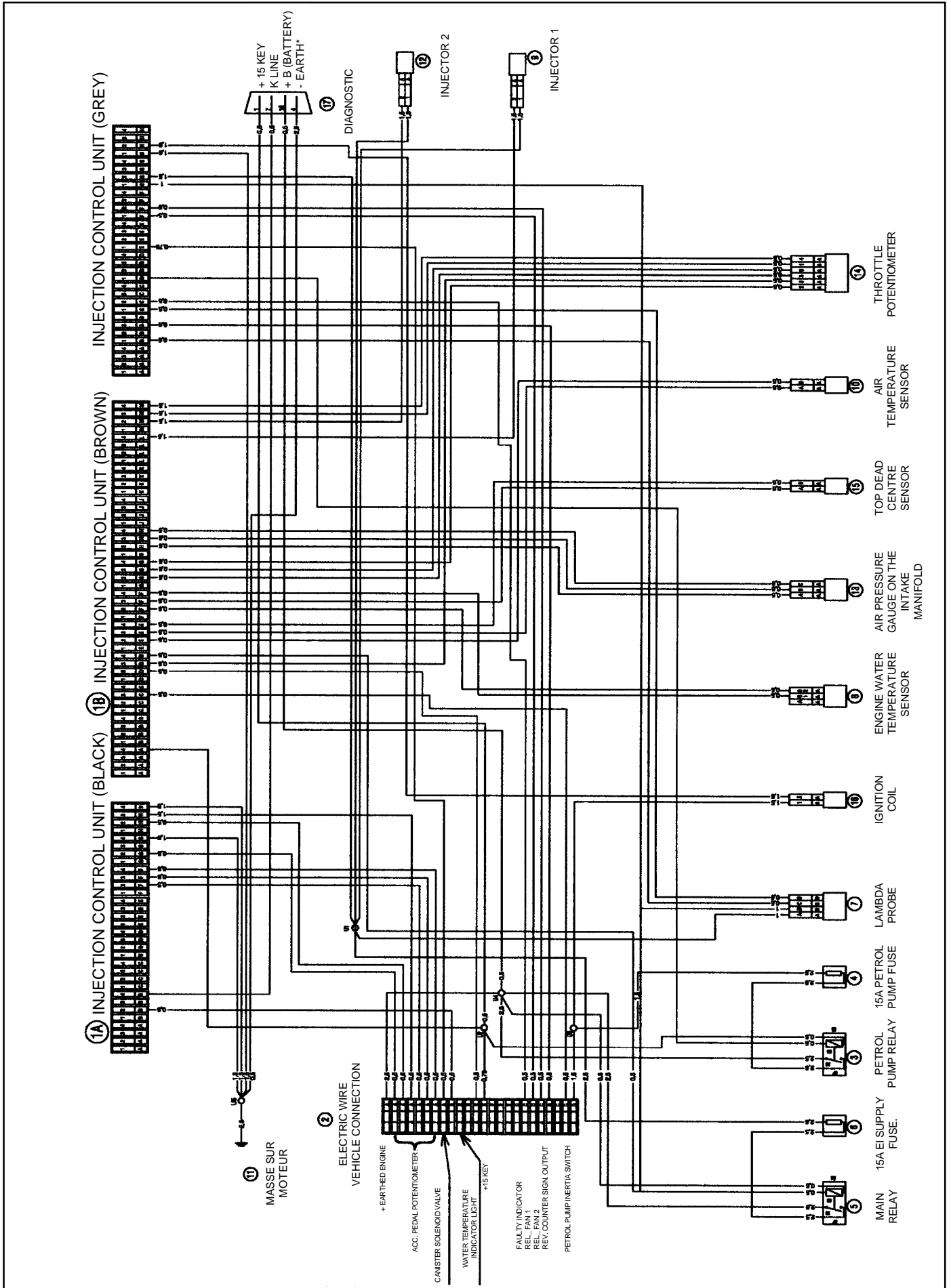

2.14 ELECTRICAL WIRING FOR ELECTRONIC ENGINE CONTROL

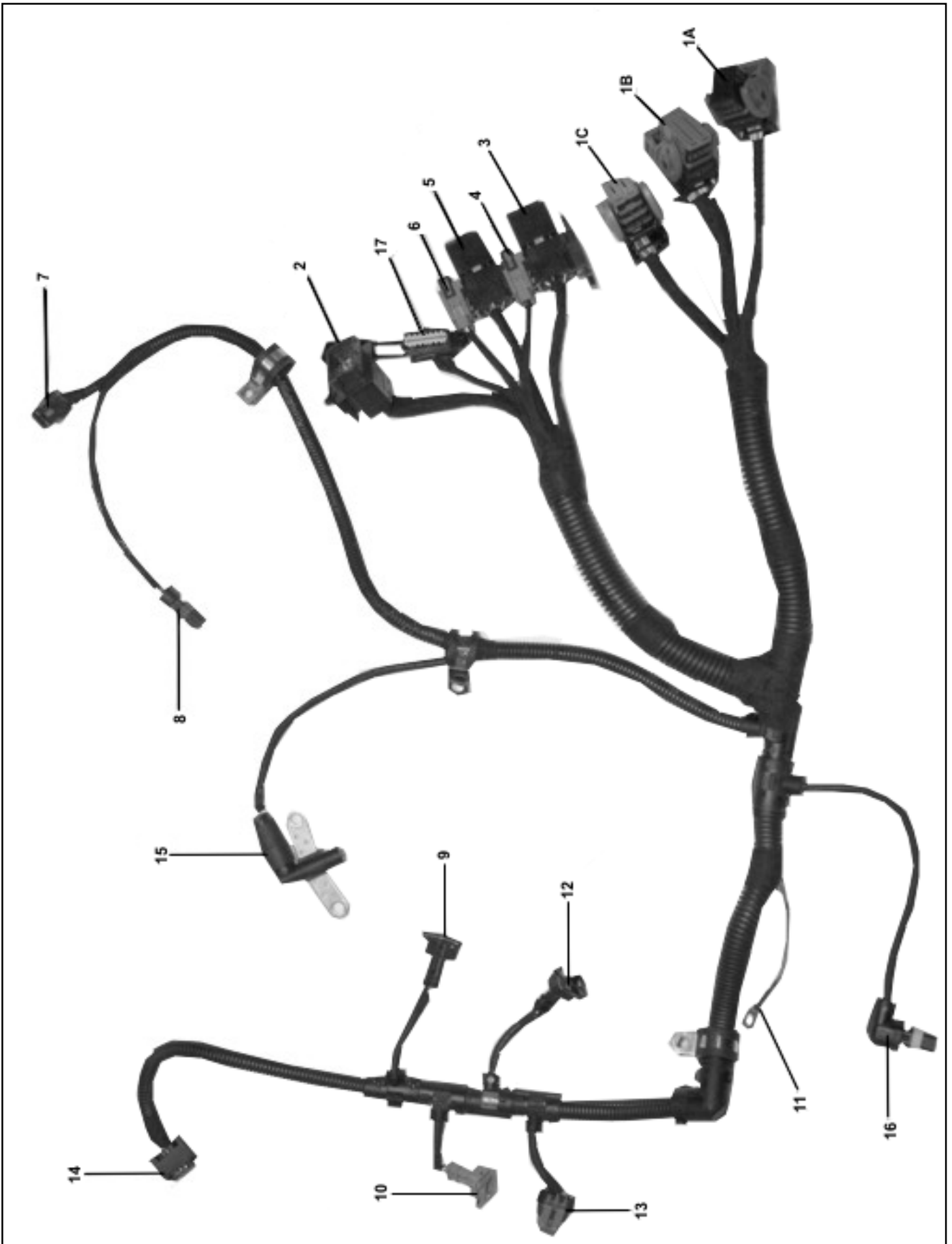

See page 20 for descriptions and reference numbers.

2.15 FUEL SUPPLY SYSTEM

2.15.1 Electric fuel supply pump

(not supplied by Lombardini)

Required features:

Capacity: 20 l/h

Minimum pressure 3.5 bars

The fuel supply pipe may be external or submerged in the tank:

- Example of external pump:

- 1 Electric fuel supply pump
- 2 Fuel filter
- 3 Pressure regulator

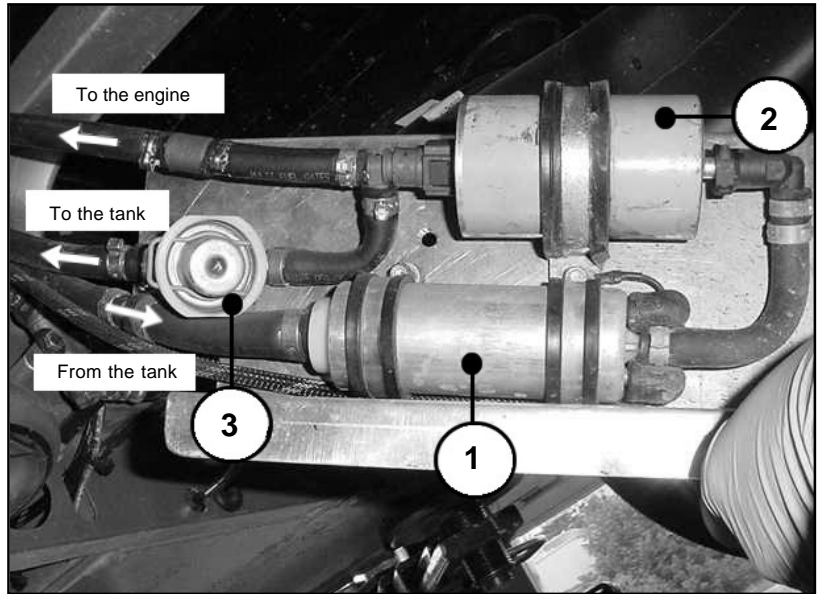

- Example of submerged pump:

- 1 Electric fuel supply pump
- 2 Fuel filter
- 3 Pressure regulator
- 4 Prefilter
- 5 Fuel level indicator

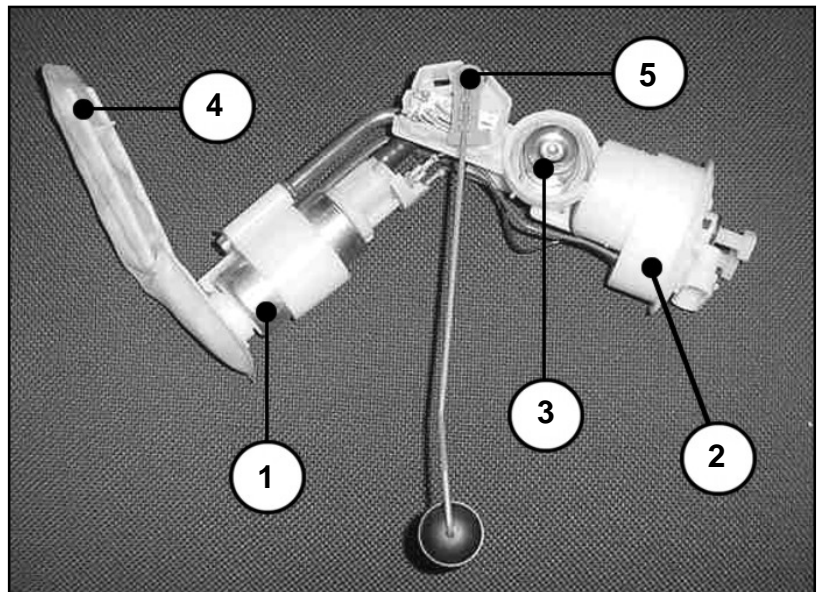

2.15.2 Fuel filter

(not supplied by Lombardini)

Required features:

Filtering capacity: 8-10 ìm

Please comply with the manufacturer's data when replacing.

2.15.3 Pressure regulator

(Calibrated to 3.5 bars)

2.15.4 Prefilter

Filtering capacity: 70 ìm

2.15.5 Injector supply pipe

Non-return complete with quick-fitting hose-end fitting.

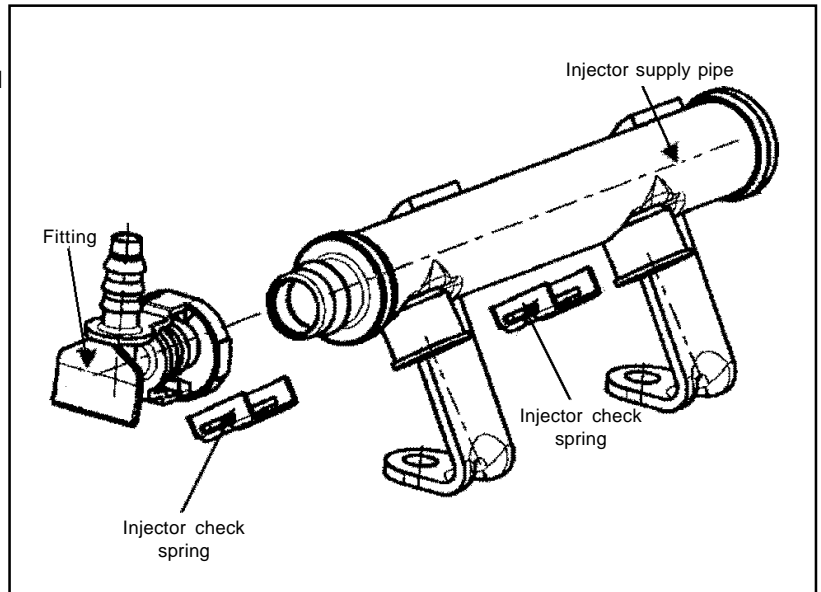

2.15.6 Injectors

Static flow: 53.5 - 58.5 cc/min at 3.5 bars
Resistance: 12Û(20°C)

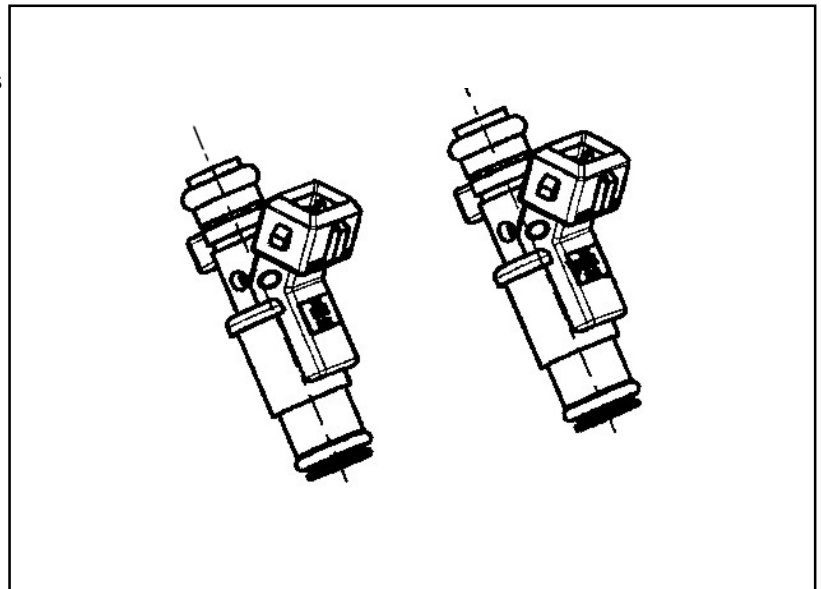

2.15.7 Inertial switch

(not supplied by Lombardini)

Cuts off fuel supply pump in the event of violent collisions. Usually located inside the cabin.

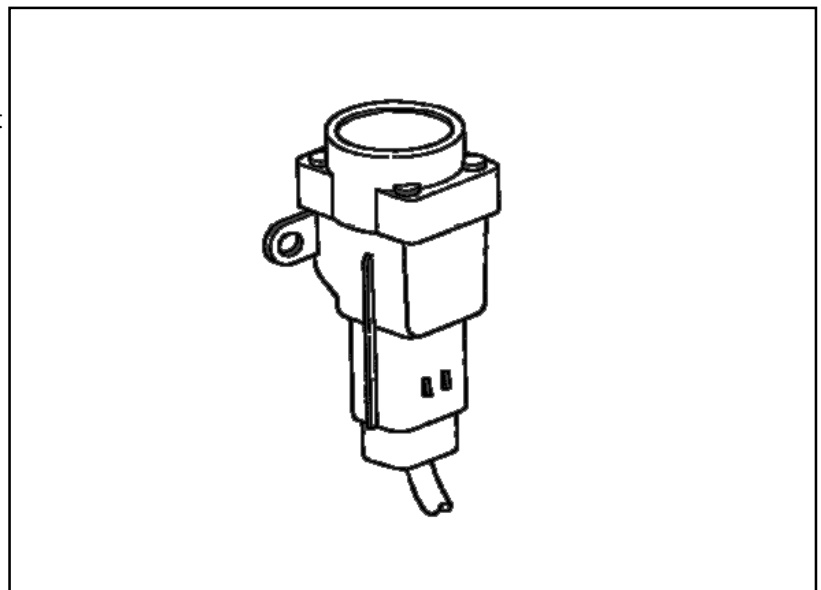

2.16 ELECTRONIC ENGINE CONTROL SYSTEM

Indirect multipoint injection device with motorised throttle.

This device controls injection and ignition simultaneously, based mainly on air pressure to the intake manifold, the throttle angle, air flow temperature, coolant temperature, the position and speed of the crankshaft.

Regulation of the air/petrol mixture occurs continuously based on the information from the Lambda probe.

The device integrates the self-diagnostic functions and ensures protection against engine runaway and stalling.

Calibration of the control unit is done by Lombardini s.r.l. and tailored to all approved vehicles.

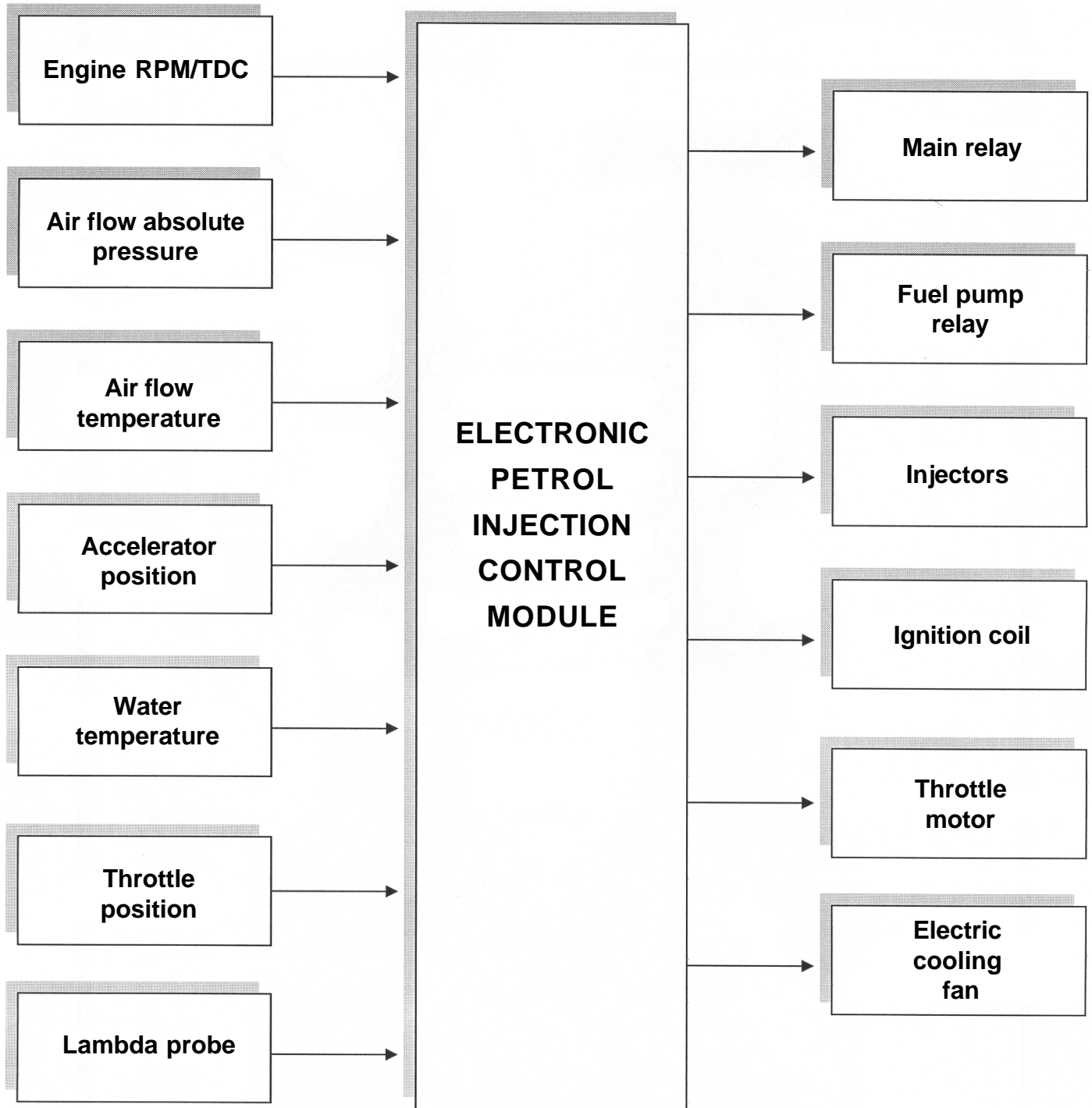

2.16.1 Ignition coil

The coil is constantly powered by the battery and controlled by the control unit. To charge the coil the control unit is connected to earth via an current circulating internal contact (regulated by the control unit at no more than 6A) and the primary magnetic circuit of the coil is charged.

The earth connection is opened at the moment when the spark is about to set off and this creates a rapid rise in voltage in the secondary circuit, thus generating the spark.

The timing of the spark is chosen from a table memorised in the control unit according to rotation speed.

The coil is activated for 1.5ms (0.0015 sec) at the end of which the spark plug is set off.

Primary winding resistance: $570\ \text{m}\Omega \pm 50\ \text{m}\Omega$

Secondary winding resistance: $7330\ \Omega \pm 500\ \Omega$

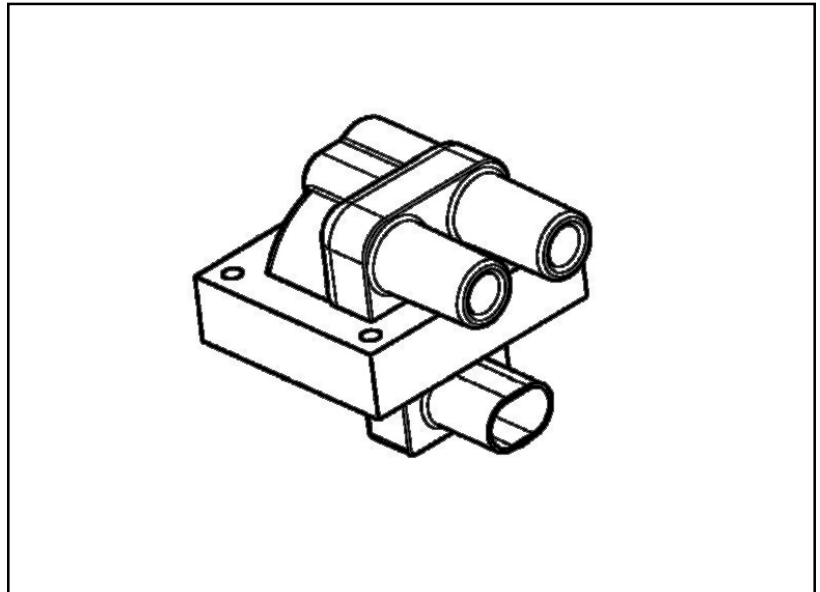

2.16.2 Spark plug

- Currently, only **EYQUEM** brand **RFN52LZ** spark plugs are allowed.
- A 16mm hexagon is used to remove and remount the spark plug.
- Length: 18mm. Thread: M14x1.25

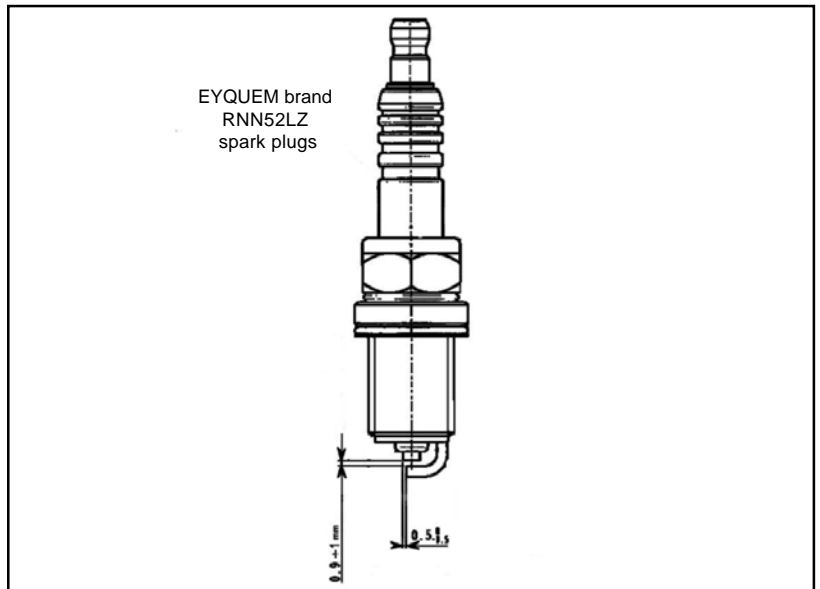

2.16.3 Lambda probe sensor

This sensor is used to detect the condition of the exhaust fumes, guaranteeing control of the exact ratio of the air/petrol mixture, which is fundamental for correct functioning of the engine and the catalytic converter.

Components:

- 1 «CINCH» Connector
- 2 Protective pipe
- 3 Formed PTFE pipe
- 4 Sensor

Resistance: $9\ \Omega$

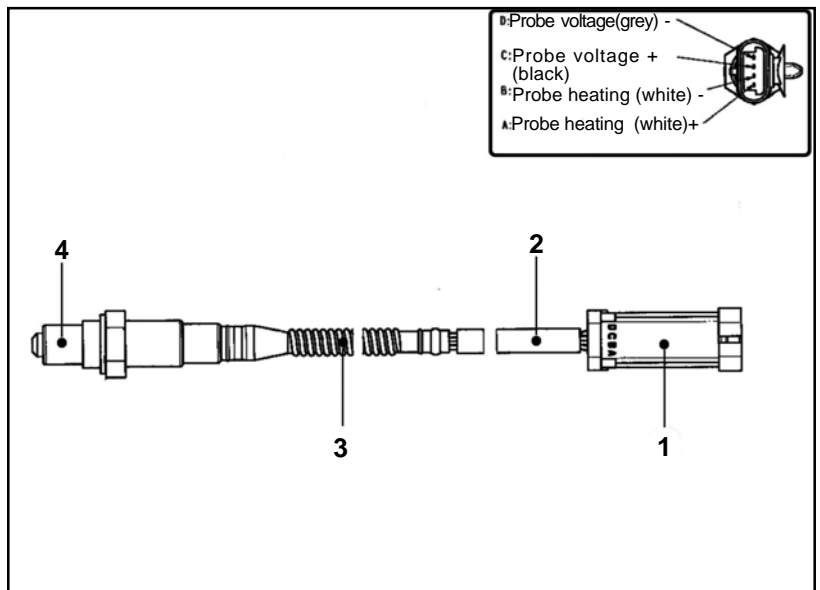

2.16.4 Electronic control unit (E.C.U.)

The electronic control unit controls the engine and the vehicle.

Important

- The control unit must be used exclusively with the calibration carried out by Lombardini s.r.l. for each specific vehicle.
- Control units are not interchangeable and modifiable.

Important

- Each control unit is supplied with its own adhesive identification plate.
- Attach it to the vehicle frame in a cool area safe from humidity and knocks. Do not attach it to the engine.

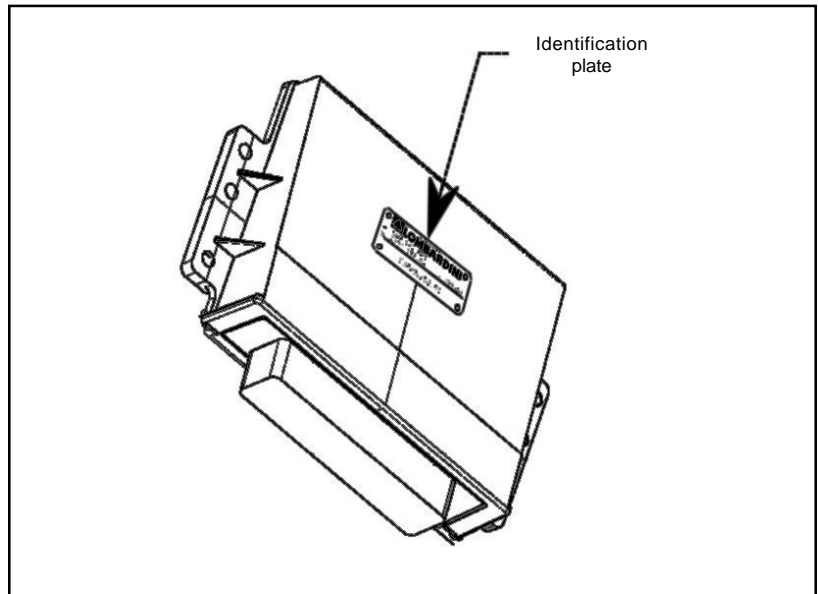

2.16.5 Control unit identification plate (Sample)

- 1 Engine type
- 2 Control unit serial number
- 3 Number of the customer version (form K)
- 4 Software version number and control unit calibration number.

Important

If it is necessary to replace the E.C.U., supply the control unit serial number carried on the identification plate to the Lombardini Spare Parts Centre.



2.16.6 Speed sensor

Coil resistance: 200Ω - 270Ω

Important

A heat-shrink sleeve should be used to secure the cable connector.

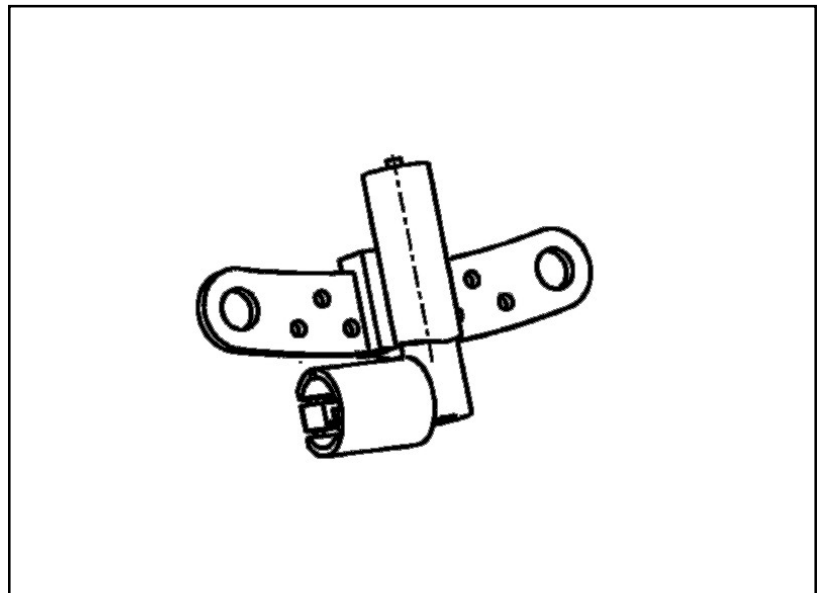

2.16.7 Air temperature sensor

Air intake temperature sensor, mounted on the intake manifold.

Heat resistance values		
Temp. °C	R Nom. Ω	Tot. Ω ± %
20	2509,3	6,5
40	1157,1	5,9

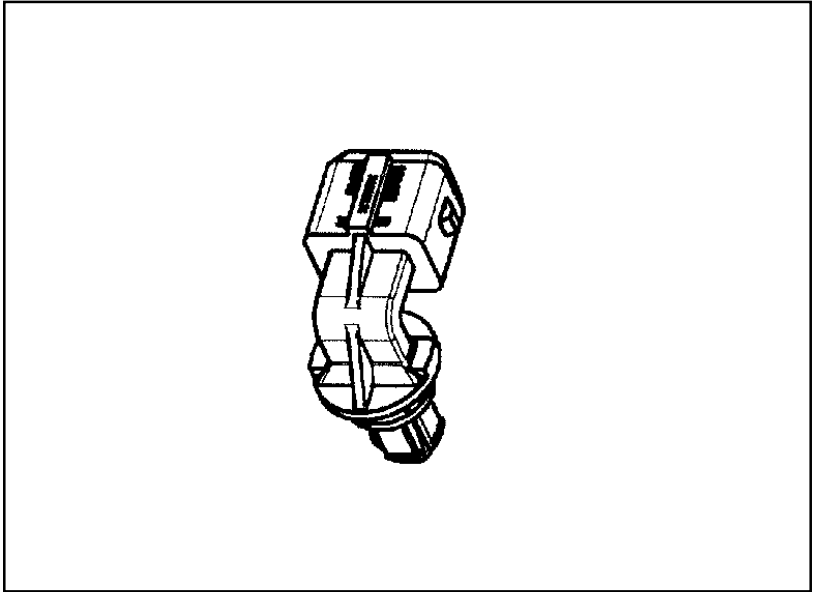

2.16.8 Absolute pressure sensor

This sensor is attached to the intake manifold to detect absolute pressure.
Output voltage: 5V ±0.25V

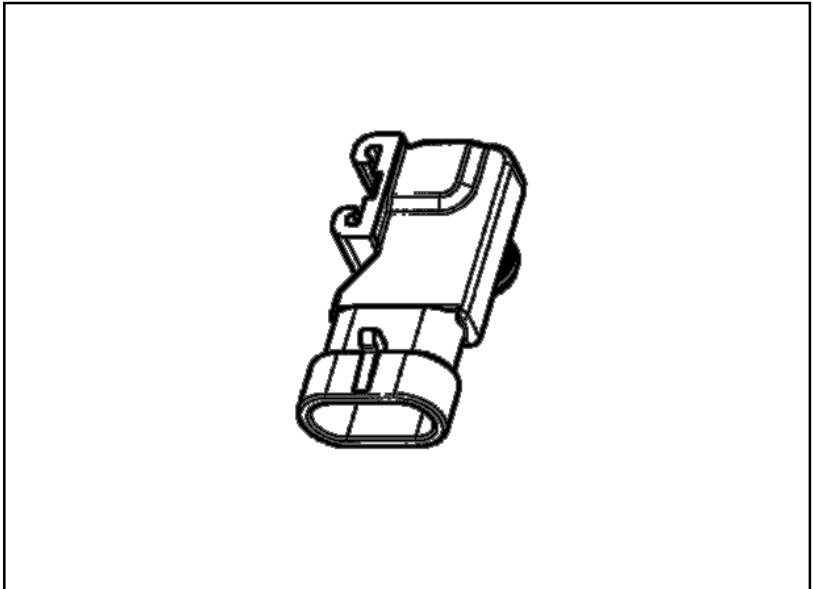

2.16.9 Water temperature sensor

Temperature sensor for the water in the cooling circuit, attached to the thermostat case.

Temp. °C	Heat resistance CTN INJ with P1 - P2 (resistance in Ω)	
25	2252	±112,1
80	282,63	±7,83

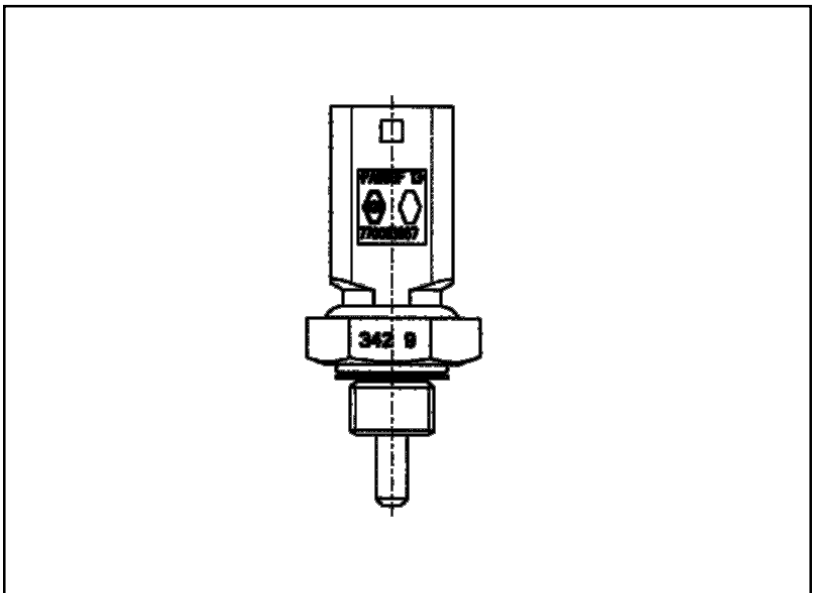

2.16.10 Throttle control sensor

Sensor that determines opening of the throttle.

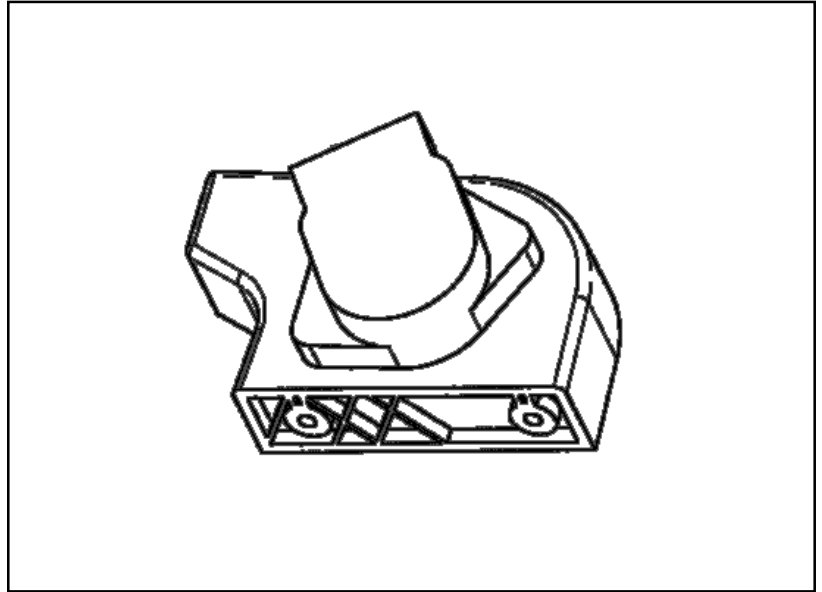

2.16.11 Throttle body

This is assembled on the intake manifold via four stud bolts and regulates air flow into the intake manifold based on information from the control unit.

DC motor: Resistance 1.5 Ω Potentiometer:
Resistance 1.25 kΩ ± 30%

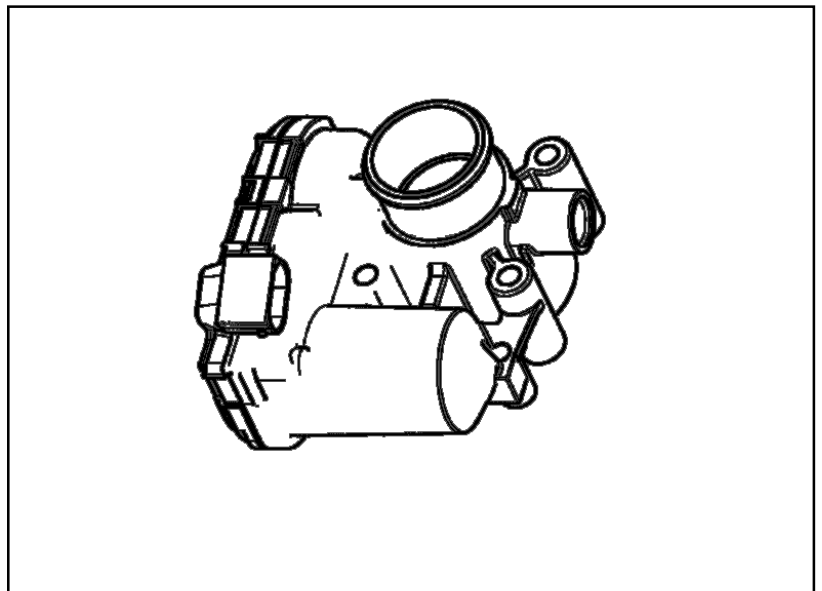

2.17 INTAKE SYSTEM

Components:

- 1 Air filter
- 2 Air filter hose/throttle body
- 3 Throttle body
- 4 Breather pipe
- 5 Air intake filter
- 6 Intake manifold
- 7 Fresh air the intake pipe

Important

The air intake system must in no way be altered from the specifications approved by Lombardini for the version. Any modifications prevent the proper functioning of the engine.

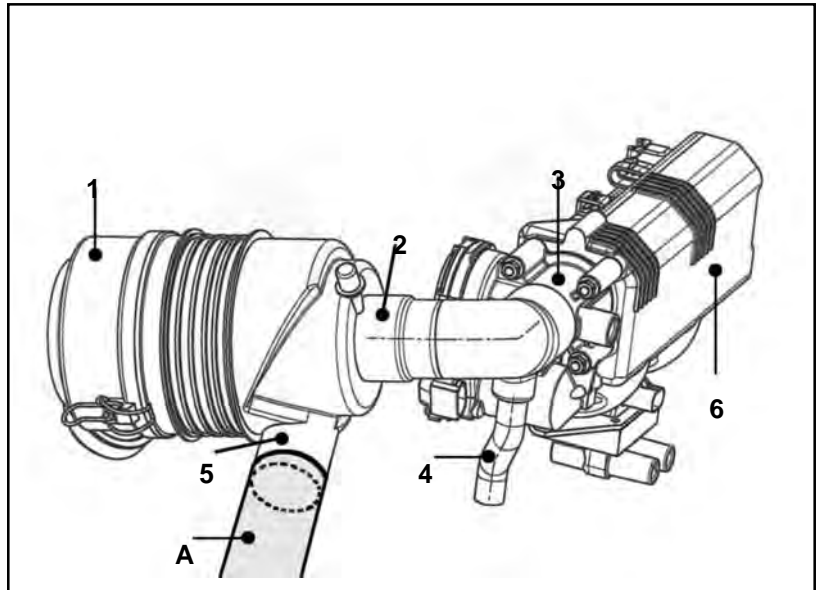

2.18 EXHAUST SYSTEM

Components:



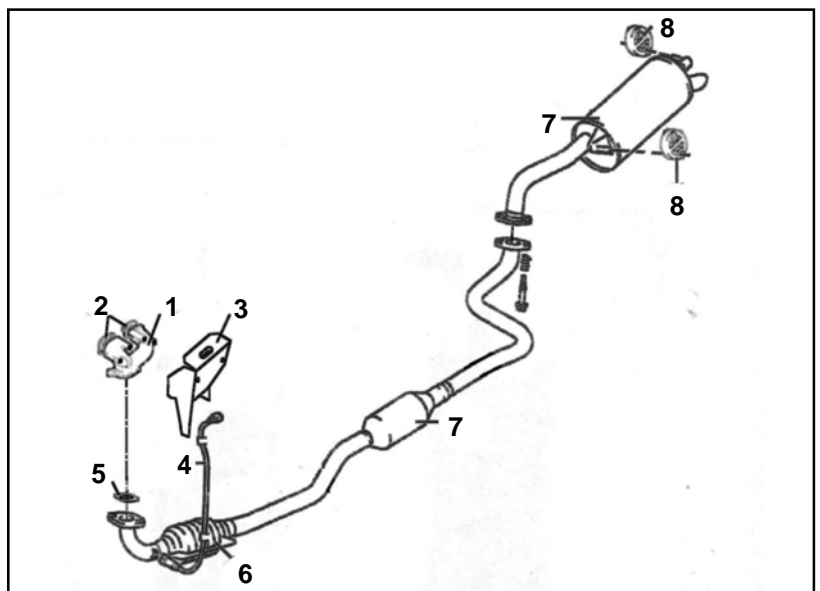

- 1 Exhaust manifold
- 2 Manifold gaskets
- 3 Thermal protection
- 4 Lambda probe
- 5 Flange/muffler gasket
- 6 Catalytic converter
- 7 Silencers
- 8 Elastic supports

Important

The exhaust system must in no way be altered from the specifications approved by Lombardini for the version. Any modifications prevent the proper functioning of the engine.



2.19 SPECIAL TOOLS AND EQUIPMENT FOR MAINTENANCE

Serial number	Description	Serial number	Description
1460-191 	Diagnostic instrument	7107-1460-047 	Tool for installing intake and exhaust valve guide gasket
7107-1460-051 	Driving shaft clamping tool	7107-1460-049 	Tool for adjusting timing belt tension









Nelle tabelle sono riportate le coppie di serraggio per le viti standard ed i componenti principali.

2.20 TIGHTENING TORQUE TABLES









The tables show the tightening torques for standard screws and the main components.

Tightening torques are provided again, along with method and sequence, in the instructions for assembling components and/or assemblies

2.20.1 Table of tightening torques for standard screws (coarse thread)

Quality/ Dimensions	Resistance class (R)							
								
	R>400N/mm ²		R>500N/mm ²		R>600N/mm ²	R>800N/mm ²	R>1000N/mm ²	R>1200N/mm ²
Diameter	Nm	Nm	Nm	Nm	Nm	Nm	Nm	Nm
M3	0,5	0,7	0,6	0,9	1	1,4	1,9	2,3
M4	1,1	1,5	1,4	1,8	2,2	2,9	4,1	4,9
M5	2,3	3	2,8	3,8	4,5	6	8,5	10
M6	3,8	5	4,7	6,3	7,5	10	14	17
M8	9,4	13	12	16	19	25	35	41
M10	18	25	23	31	37	49	69	83
M12	32	43	40	54	65	86	120	145
M14	51	68	63	84	101	135	190	230
M16	79	105	98	131	158	210	295	355
M18	109	145	135	181	218	290	405	485
M20	154	205	193	256	308	410	580	690
M22	206	275	260	344	413	550	780	930
M24	266	355	333	444	533	710	1000	1200
M27	394	525	500	656	788	1050	1500	1800
M30	544	725	680	906	1088	1450	2000	2400

2.20.2 Table of tightening torques for standard screws (fine thread)

Quality/ Dimensions	Resistance class (R)							
								
	R>400N/mm ²		R>500N/mm ²		R>600N/mm ²	R>800N/mm ²	R>1000N/mm ²	R>1200N/mm ²
Diameter	Nm	Nm	Nm	Nm	Nm	Nm	Nm	Nm
M 8x1	10	14	13	17	20	27	38	45
M 10x1	21	28	26	35	42	56	79	95
M 10x1,25	20	26	24	33	39	52	73	88
M 12x1,25	36	48	45	59	71	95	135	160
M 12x1,5	38	45	42	56	68	90	125	150
M 14x1,5	56	75	70	94	113	150	210	250
M 16x1,5	84	113	105	141	169	225	315	380
M 18x1,5	122	163	153	203	244	325	460	550
M 18x2	117	157	147	196	235	313	440	530
M 20x1,5	173	230	213	288	345	460	640	770
M 20x2	164	218	204	273	327	436	615	740
M 22x1,5	229	305	287	381	458	610	860	1050
M 24x2	293	390	367	488	585	780	1100	1300
M 27x2	431	575	533	719	863	1150	1600	1950
M 30x2	600	800	750	1000	1200	1600	2250	2700

2.20.3 Table of tightening torques for the main components

Description	Diameter x thread (mm)	Tightening torques (Nm)
Connecting rod	8x1	50
Rocker arm cover	6x1	9
Crankcase (screws for fixing crankshaft)	M 10	50
Crankcase (screws for fixing engine block)	M 6	10
Timing belt pulley nut	M 10	40
Rocker arm support nut	10x1,5	40
Oil sealing ring flange screws (flywheel side)	M 6	12
Crankshaft pulley screw (timing belt side)	16x1,5 sin.	180 ⁽¹⁾
Camshaft pulley screw	10x1,25	50
Timing belt shaft bearing plate	M6x1	10
Camshaft support flange	M6x1	10
Seal flange	M6x1	10
Intake manifold fastening screw	M6x1	10
Speed sensor support screw	M6x1	10
Speed sensor screw	M8x1,25	10
Oil pressure switch		25
Oil plug	12x1,5	40
Cylinder head screws	12x1,5	⁽²⁾
Flywheel screws		80
Coolant thermostat	10x1,5	30

⁽¹⁾ Lubricate the underside of the screw and pulley centring pin with «Molyslip».

⁽²⁾ For more detailed information see «Assembling the cylinder head».

2.21 TABLE OF SEALANTS

<i>Area of application</i>	<i>Sealant</i>
Oil filter cartridge union (M 20x1.5)	Loctite 601
Timing shaft bearing screw (M 6)	Loctite 270
Stud bolt for tightening pulley (M 10)	Loctite 601
Cylinder head plug (Ø 18)	Loctite 510
Engine and engine block cylinder head plug (Ø 30)	Loctite 510
Oil pump fastening TE screw	Loctite 270
Oil circuit surfaces between crankcase and engine block	Loctite Q3 7091

Notes :

.....

.....

.....

.....

.....

.....

.....

.....

.....

.....

.....

.....

.....

.....

.....

.....

.....

.....

.....

.....

.....

.....

.....

.....

.....

3.1 TABLE OF LIKELY ANOMALIES AND THEIR SYMPTOMS

The engine does not start

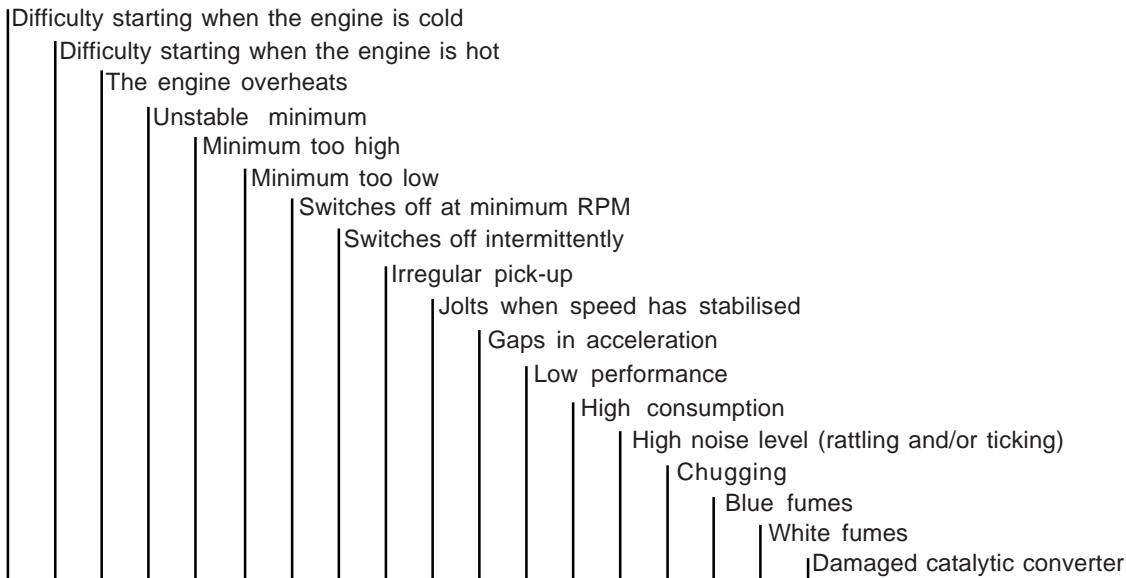

													Air supply	
														Air filter
														Leaking manifold
														Throttle body
													Fuel supply	
														The pressure regulator stays open
														The pressure regulator stays closed
														Blocked pipes
														No pump delivery
														Dripping injector
														Bad fuel quality
													Ignition	
														Coil (short circuit in winding)
														Defective spark plug wires
														Worn spark plugs
														Spark plugs too cold
														Spark plugs too hot
													Exhaust	
														Leaking manifold
														Lambda probe
													Engine and mechanics	
														Badly sealed intake valve
														Sticking valve
														Badly sealed valve guide
														Casing/piston wear and tear
														Caked combustion chamber
														Insufficient cooling
														Damaged cylinder head gasket
														Damaged rotation sensor phonic wheel
														Faulty hydraulic tappets
														Oil level too high
													Electrical system	
														Bad fuel pump connector contact
														Burnt-out fuse
														Faulty relays
														Faulty engine wiring
														Battery element out of order
														Sulphurised battery clamps

Notes :

.....
.....
.....
.....
.....
.....
.....
.....
.....
.....
.....
.....
.....
.....
.....
.....
.....
.....
.....
.....
.....
.....
.....
.....
.....
.....
.....
.....
.....
.....
.....
.....
.....
.....
.....
.....
.....
.....
.....
.....
.....
.....
.....
.....
.....
.....
.....
.....
.....
.....

4.1 HANDLING AND LIFTING

- Secure the engine using a lifting device (lifting beam) of suitable capacity.
- Hook the lifting device to the points indicated in the drawing.
- Before lifting, check the load's centre of gravity.

Important

The dimensions of the brackets on the fastening points have been specially conceived to lift only the engine and have not been tested for lifting additional weights. Do not lift the engine using different methods from those described. Non-observance of this requirement will invalidate the insurance warranty from any damages caused in this way.

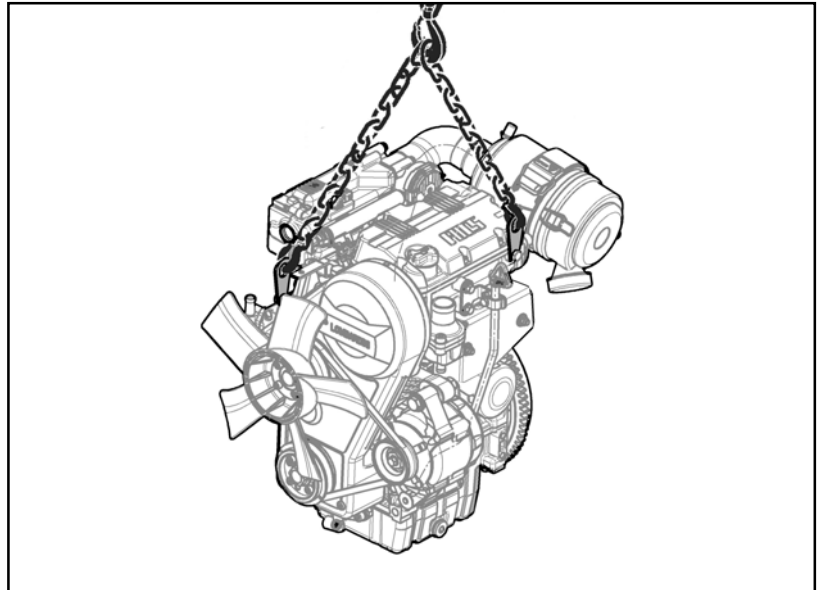

4.2 STORING THE ENGINE (UNINSTALLED)

- If the engine is not to be used for extensive periods, check the surroundings and the type of packaging and make sure that these are suitable for correct storage.
If necessary, cover the engine with a protective sheet.
- Avoid storing the engine directly on the ground or in an environment that is humid, exposed to bad weather or close to sources of danger, including less visible hazards such as high-voltage power lines, etc.

Important

If the engine is not to be used for more than 1 month, it is necessary to apply protective measures that are valid for 6 months (see «Protective treatment»).

Important

If, after the first 6 months, the engine is still not to be used, it is necessary to carry out a further measure to extend the protection period (see «Protective treatment»).

4.3 ENGINE STORAGE (INSTALLED)

If the engine has been installed on a vehicle and is not due to be used for extensive periods, it is necessary to carry out a few maintenance measures in order to ensure it remains efficient and to protect its components.

If the engine is installed on the vehicle and is not to be used for short periods of time, the following measures must be carried out:

- Check the condition of the electrical contacts and protect them, if necessary, using an anti-rust spray.
- Disconnect the battery.
- Empty the fuel tank to prevent the risk of fire.
- Remove the key from the dashboard and put it in a safe place to avoid acts of vandalism.
- Lock the cabin and the cowls to prevent strangers getting access.

Important

If the engine is not to be used for more than 1 month, it is necessary to apply protective measures that are valid for 6 months (see «Protective treatment»).

Important

If, after the first 6 months, the engine is still not to be used, it is necessary to carry out a further measure to extend the protection period (see «Protective treatment»).

4.4 PROTECTIVE TREATMENT

- 1 - Check that the engine oil and coolant are up to level.
- 2 - Start the engine and keep idle at minimum speed for 15 minutes.
- 3 - Switch off the engine.
- 4 - Remove the lubrication oil.
- 5 - Fill the casing with AGIP RUSTIA protective oil.
- 6 - Start the engine and check for fuel and oil leaks.
- 7 - Start the engine and bring to $\frac{3}{4}$ of the maximum speed for 5-10 minutes.
- 8 - Switch off the engine.
- 9 - Empty the fuel tank completely.
- 10 - Replace the fuel filter.
- 11 - Spray SAE 10W oil on the exhaust and intake manifolds.

- 12 - Close all openings to prevent foreign bodies from entering.
- 13 - Thoroughly clean all external parts of the engine using suitable products.
- 14 - Treat non-painted parts with protective products (AGIP RUSTIA 100/F).
- 15 - Loosen the alternator/fan belt.
- 16 - If necessary, cover the engine with a protective sheet.



Important

After a year of engine inactivity, the coolant loses its properties and must be replaced.

4.5 PREPARING THE ENGINE FOR OPERATION AFTER PROTECTIVE TREATMENT

After a period of inactivity and before installing and running the engine, it is necessary to carry out a few measures in order to ensure that it runs at maximum efficiency.

- 1 - Remove the protective sheet.
- 2 - Eliminate any blockages in the exhaust and intake ducts.
- 3 - Use a cloth soaked in degreasing product to remove the external protective treatment.
- 4 - Remove the intake manifold.
- 5 - Inject lubrication oil (no more than 2 cm³) into the valves and install the intake manifold.
- 6 - Adjust the alternator/fan belt tension.
- 7 - Turn the flywheel manually to check the movement of the mechanical parts.
- 8 - Refill the tank with fresh fuel.
- 9 - Start the engine and bring to $\frac{3}{4}$ of the maximum speed for 5-10 minutes.
- 10 - Switch off the engine.
- 11 - Remove the protective oil to replace with engine oil.
- 12 - Introduce new oil (see «Table of lubricants») up to the correct level marked on the dipstick.
- 13 - Replace the filters (air, oil, fuel) with original spare parts.
- 14 - Empty the cooling circuit completely and pour in the new coolant up to the correct level.



Important

Over time, a number of engine components and lubricants lose their properties, even when the engine is not in use, and so it is important to consider whether they need replacing, based not only on the number of hours of use, but also on age and wear.

- 15 - Install the engine onto the vehicle and make the necessary connections and unions.
- 16 - Make sure that electrical contacts are intact and efficient.
- 17 - Check that the engine oil and coolant are up to level.
- 18 - Start the engine and keep at minimum speed for a few minutes.
- 19 - Check for leaks and, if necessary, find and eliminate the cause.
- 20 - Switch off the engine.
- 21 - Double check that the engine oil and coolant are up to level.

5.1 RECOMMENDATIONS FOR REMOVING THE ASSEMBLIES

Important

To locate specific topics, the reader should refer to the index.

- Before any intervention, the operator should lay out all equipment and tools in such a way as to enable him to carry out operations correctly and safely.
- Before proceeding with operations, make sure that appropriate safety conditions are in place, in order to safeguard the operator and any persons involved.
- For safety and convenience, you are advised to place the engine on a special rotating stand for engine overhauls.

Caution – Warning

Please remember that any variation in the intake system during the application phase of LGW 523 engines involves a variation in fuel and mapping of the electronic control unit.

Optimisation must be carried out beforehand at Lombardini testing centres. Non-approval by Lombardini of any modifications, releases the company from any damages incurred by the engine.

5.2 REMOVING THE EXHAUST AND INTAKE MANIFOLDS

5.2.1 Disassembling the intake manifold

- 1 - Disconnect the clamp (A) from the air filter support (S).

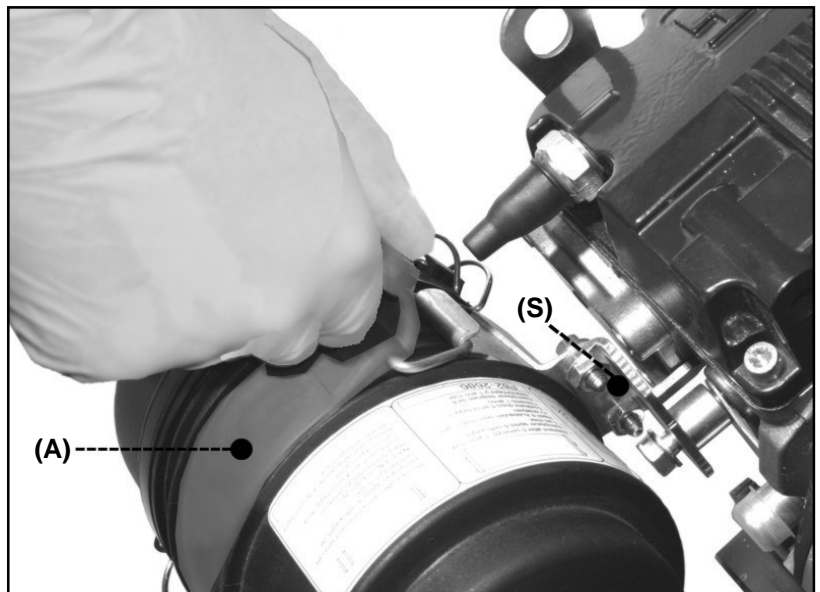

- 2 - Disconnect the breather pipe (B).
- 3 - Disconnect the air filter hose (C) from the throttle body.
- 4 - Remove the entire air filter.
- 5 - Unscrew the two fastening screws on the filter support (S) and remove it.

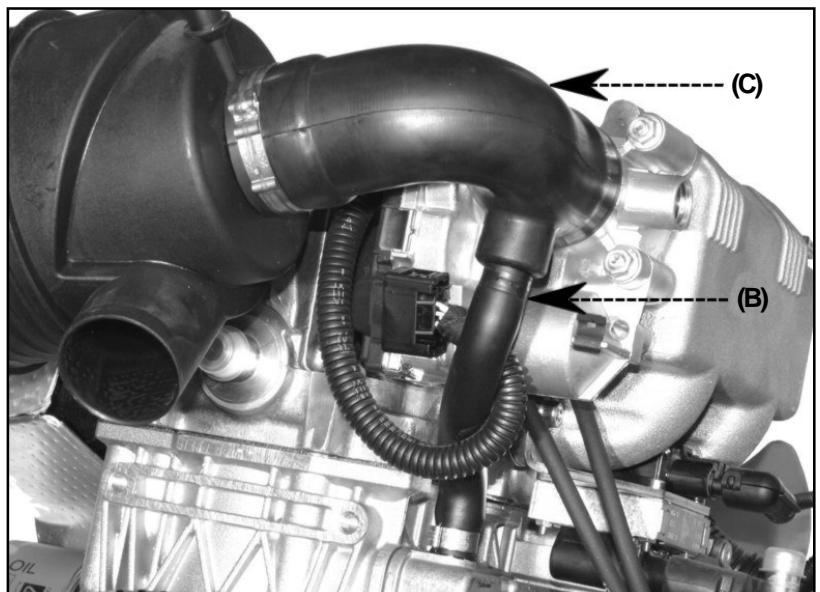

6 - Disconnect the connector (D) from the throttle body (E).

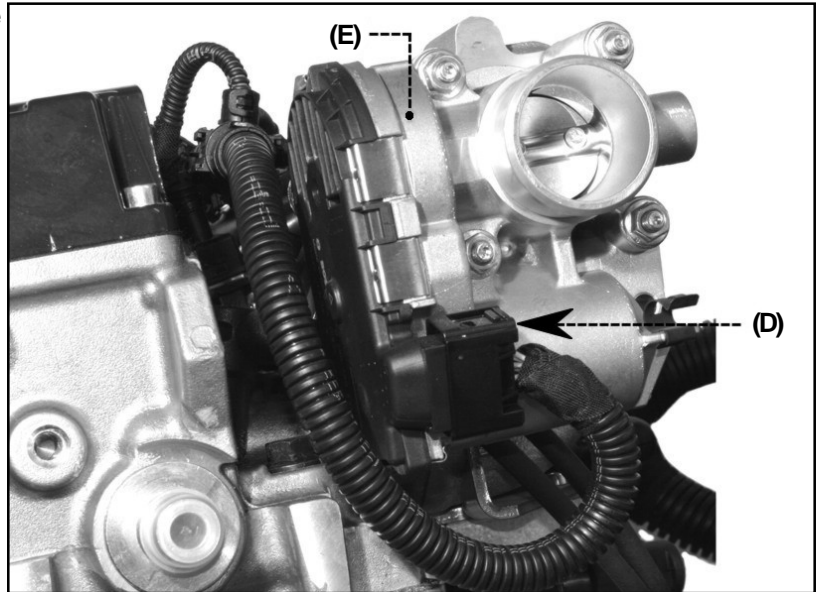

7 - Disconnect the connector (F) from the absolute pressure sensor and connector (F1) from the temperature sensor.

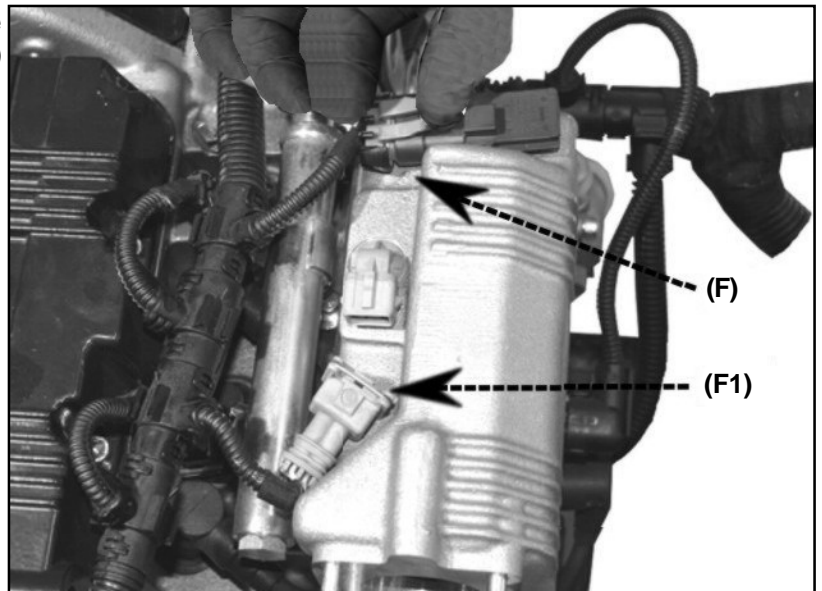

8 - Unscrew the fastening nuts and remove the throttle body.

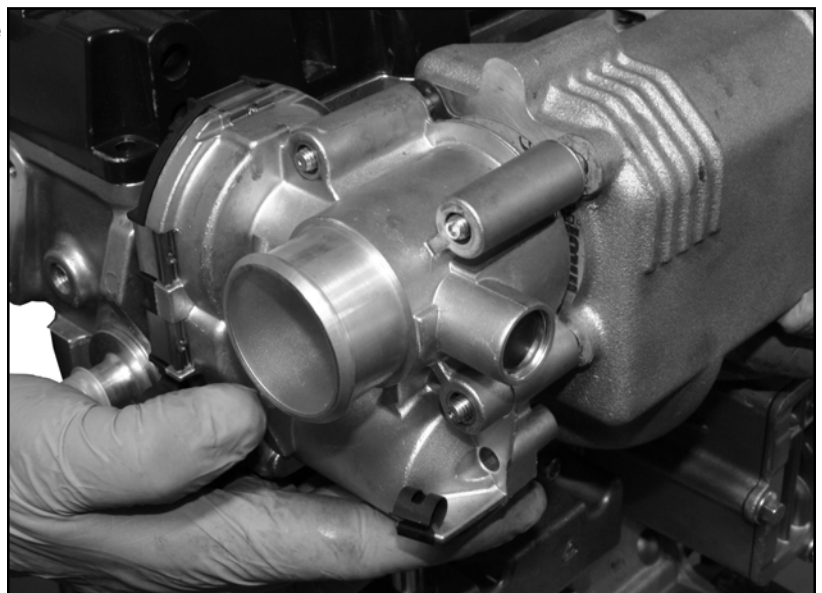

- 9** - Disconnect the spark plug power supply cables.



- 10** - Disconnect the ignition coil supply cable.
11 - Unscrew the fastening screws and remove the coil.
12 - Unscrew the fastening screws and remove the intake manifold.

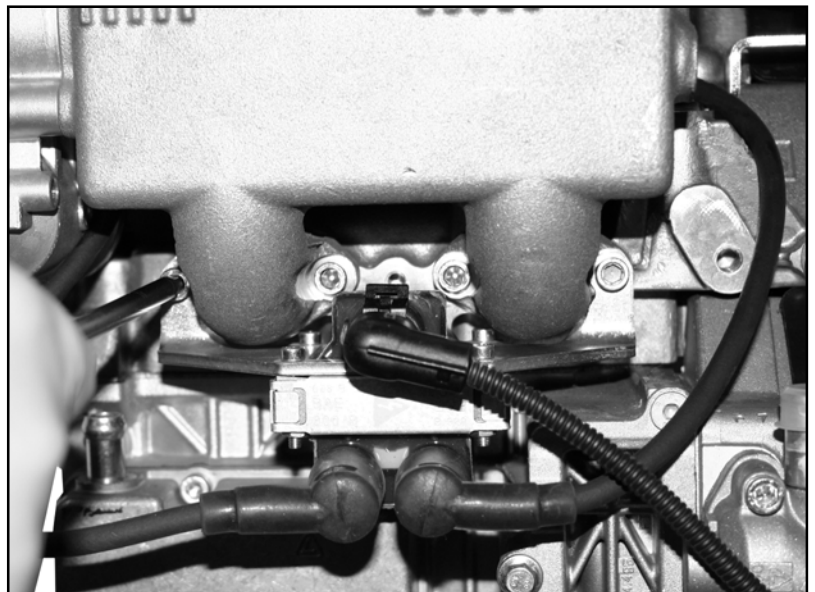

- 13** - Remove the gaskets between the cylinder head pipes and the intake manifold.
14 - Close the openings and ducts to prevent foreign bodies from entering.

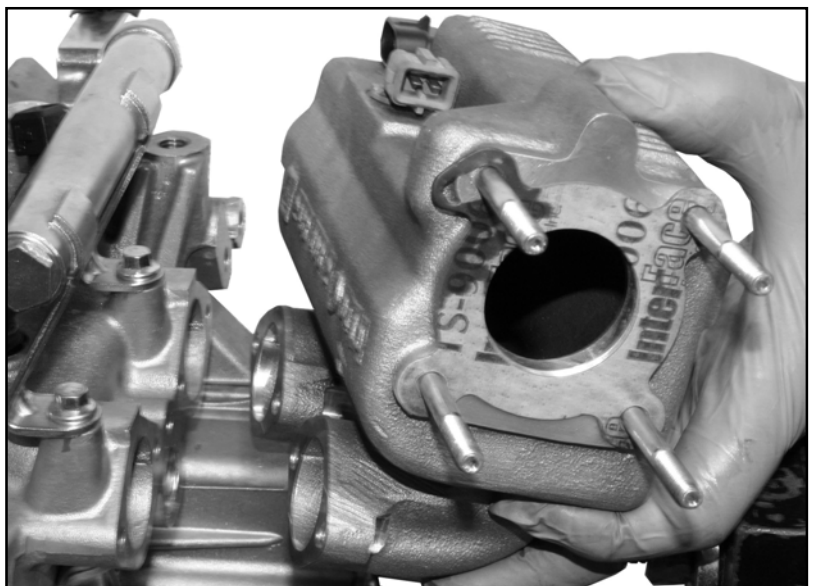

5.2.2 Disassembling the air flow sensors

- 1 - With a tool, remove the air temperature and pressure sensors from the intake manifold, taking good care not to damage them.



5.2.3 Disassembling the exhaust manifold

- 1 - Remove the case holding the dipstick.

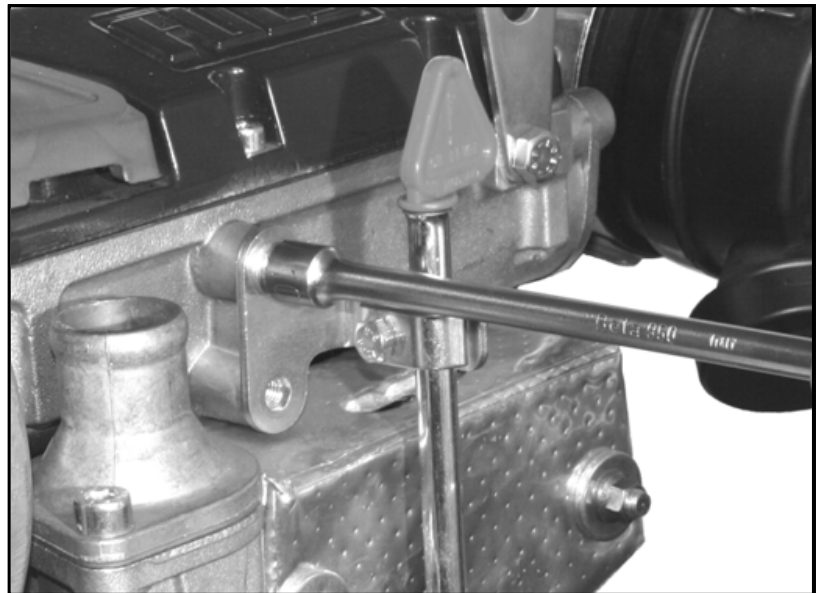

- 2 - Take off the thermal protection.

 **Caution – Warning**
Do not start the engine when the thermal protection is not in place.



- 3 - Using a 22mm spanner, loosen the nut holding the Lambda probe to the exhaust pipe. Unscrew the probe and remove. This operation should be carried out with extreme care to avoid damaging the probe or cables.

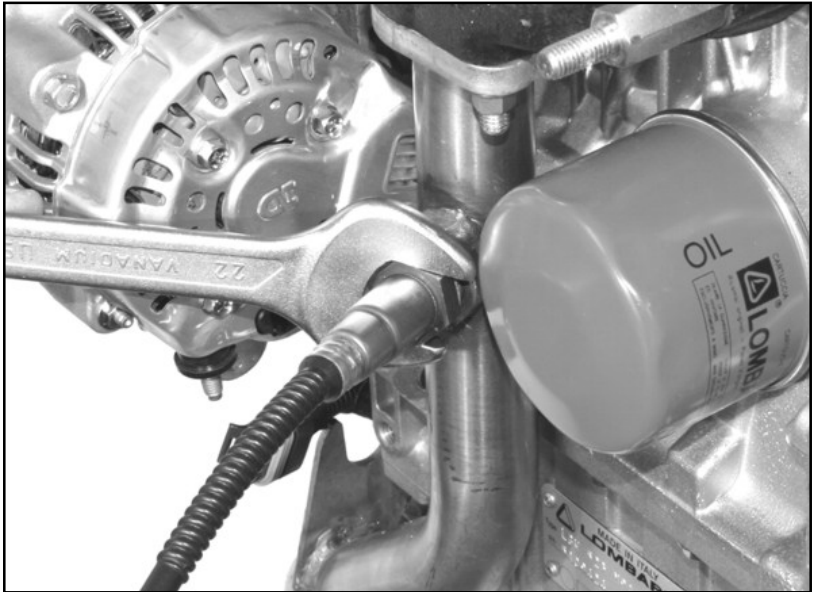

- 4 - Unscrew the fastening nuts and disassemble the exhaust manifold.
 5 - Remove the gaskets.
 6 - Close the openings and ducts to prevent foreign bodies from entering

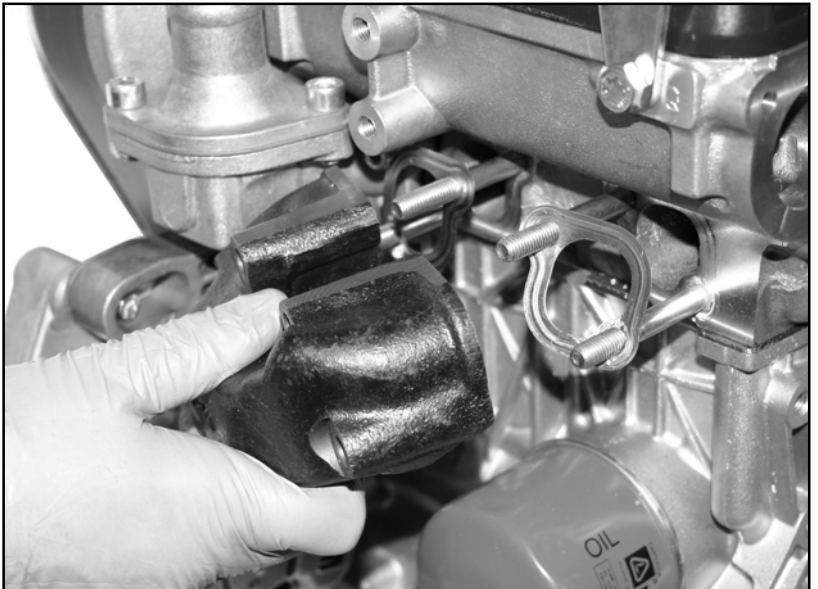

5.3 REMOVING THE COOLING FAN BELT DRIVE

 **Danger - Attention**

Before disassembling the cooling fan, isolate the positive battery cable to prevent accidental short-circuiting and, consequently, activation of the starter motor.

- 1 - Remove the cooling fan (A).

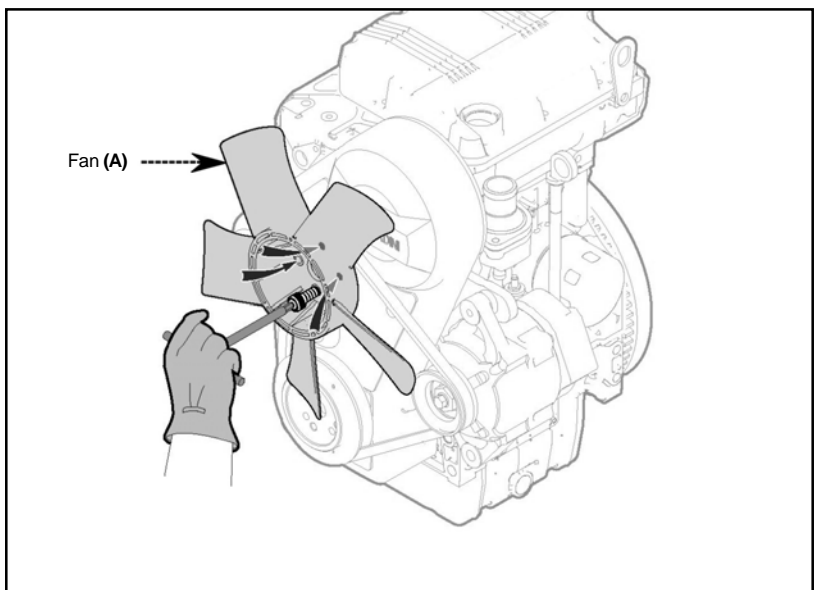

Important

The cooling fan belt drive may be for an external or internal alternator.

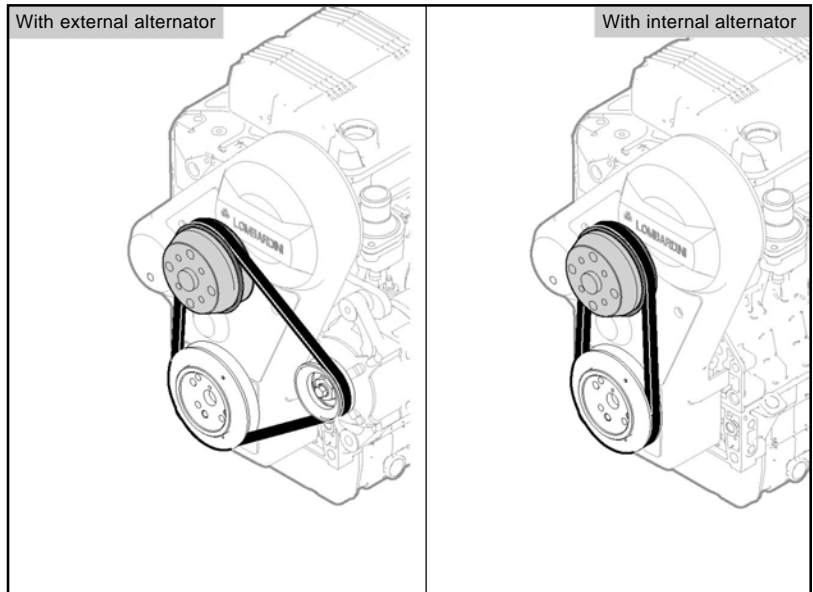

5.3.1 Disassembling the cooling fan belt (with external alternator)

- 1 - Loosen the nuts (**B - B1**).
- 2 - Loosen the belt (**D**) by adjusting the alternator (**C**) manually.
- 3 - Remove the belt (**D**).

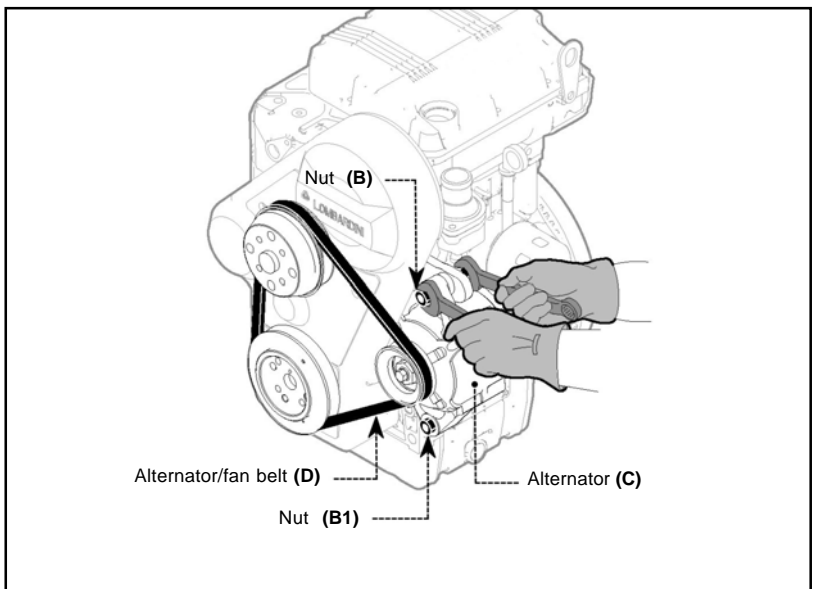

- 4 - Remove the fan hub (**E**) and flange.
- 5 - Remove the pulley (**F**), washers and spacer.

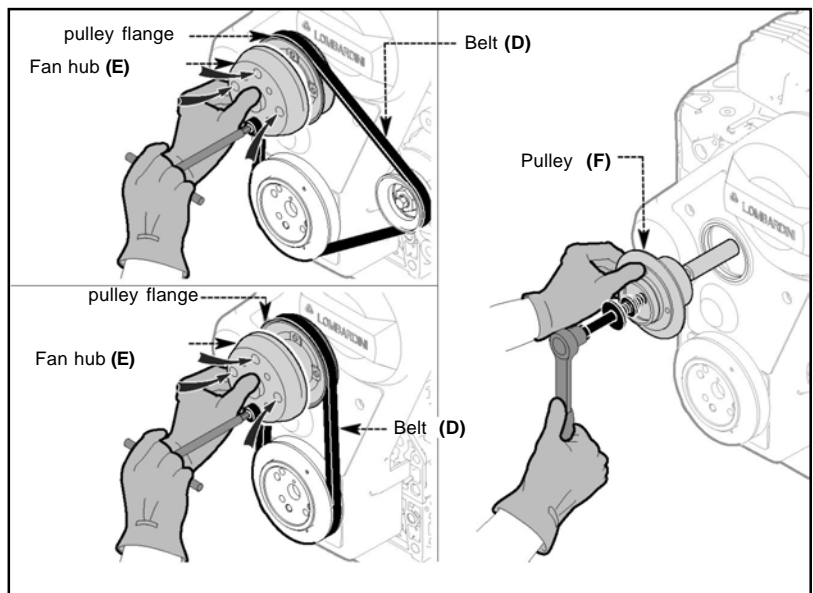

5.3.2 Disassembling the cooling fan belt (with internal alternator)

- 1 - Remove the fan hub (**E**) and flange.
- 2 - Remove the belt (**D**).
- 3 - Remove the pulley (**F**), washers and spacer

5.4 REMOVING THE TIMING BELT DRIVE

5.4.1 Disassembling the timing belt guard

- 1 - Disassemble the starter motor.
- 2 - Install tool «7107-1460-051» to inhibit rotation of the crankshaft.
- 3 - Loosen the screw **(G)**.

 **Caution – Warning**
The screw is left-handed. Turn clockwise to unscrew.

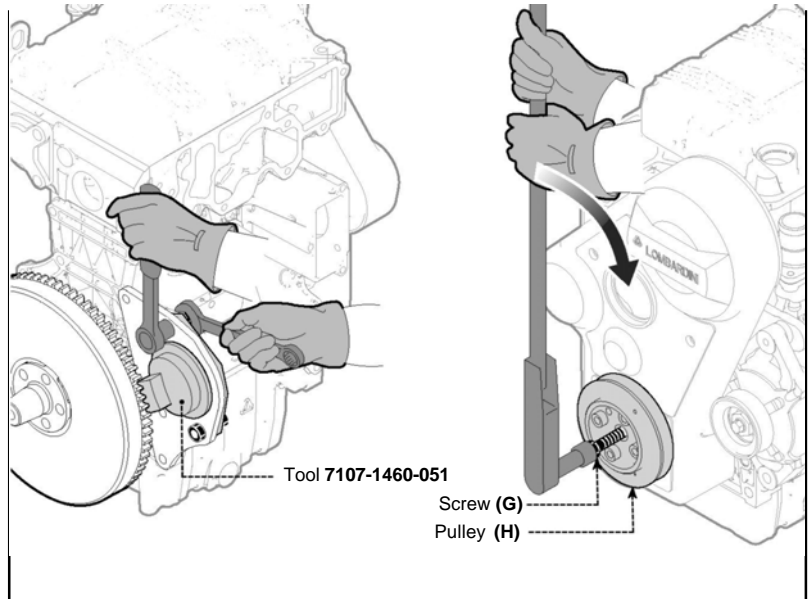

- 4 - Loosen the screw and remove the pulley **(H)**.
- 5 - Remove the guard **(L)**.

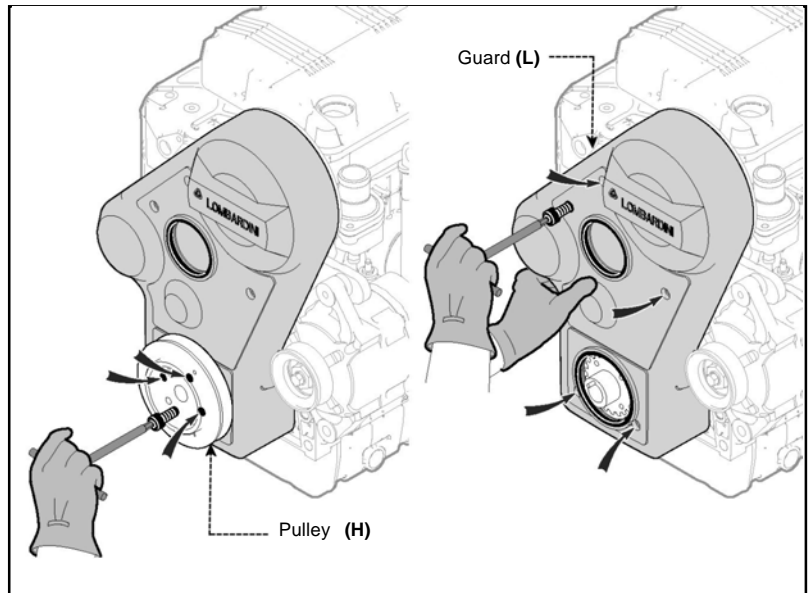

5.4.2 Timing belt and gears

Components:

- 1 Camshaft toothed pulley
- 2 Timing belt
- 3 Crankshaft toothed pulley
- 4 Coolant circulation pump gear
- 5 Sliding pulley and belt tightener
- 6 Speed sensor

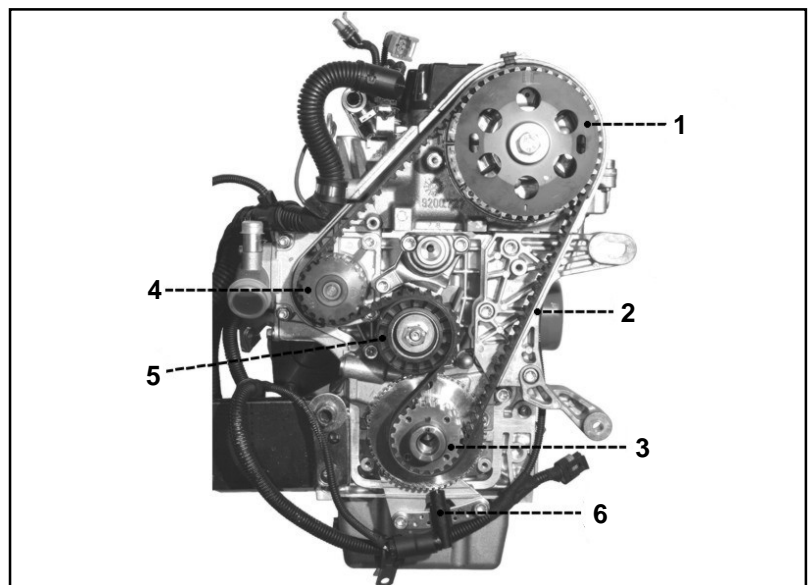

5.4.3 Removing the speed sensor

- 1 - Unscrew the fastening screws.
- 2 - Using a cutter slit the heat-shrink sleeve (A) to remove it.
- 3 - Disconnect the connector.



5.4.4 Disassembling the synchronous timing belt

- 1 - Twist the pulley nut (M) to fully loosen the belt (N).
- 2 - Remove the belt (N), working it away in sequence first from pulley (P) and then from the others.

Important

The timing belt must always be replaced with an original spare part whenever it is removed.

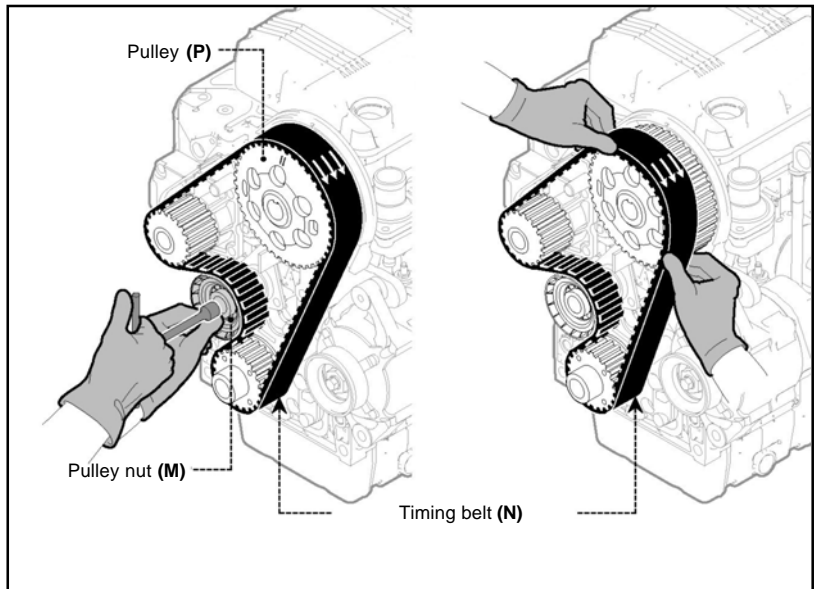

5.4.5 Sliding pulley and belt tightener

Components:

- 1 Nut
- 2 Washer
- 3 Belt sliding pulley
- 4 Ball bearing
- 5 Shaft axle
- 6 Base plane
- 7 Toothed belt tensioning lever

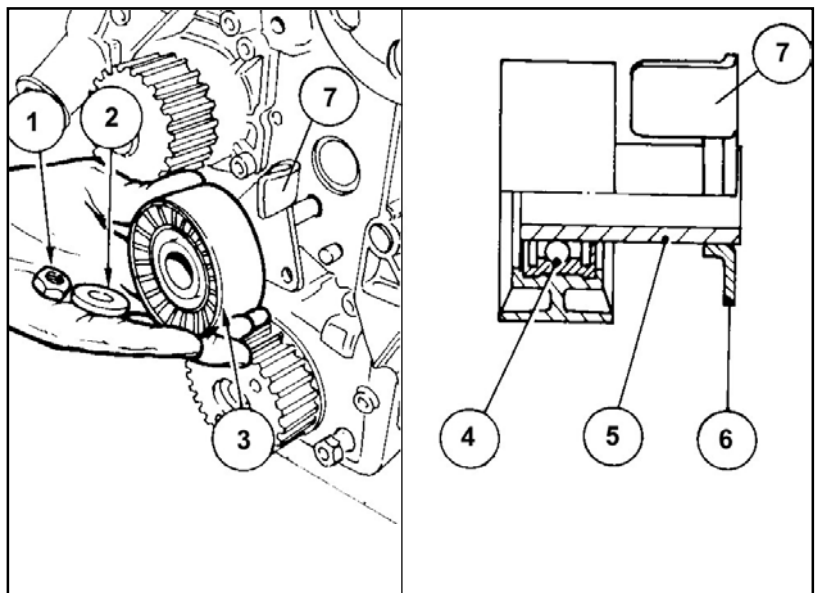

5.4.6 Disassembling the synchronous timing belt pulleys (camshaft and crankshaft)

- 1 - Remove pulley (P).
- 2 - Remove pulley (Q).

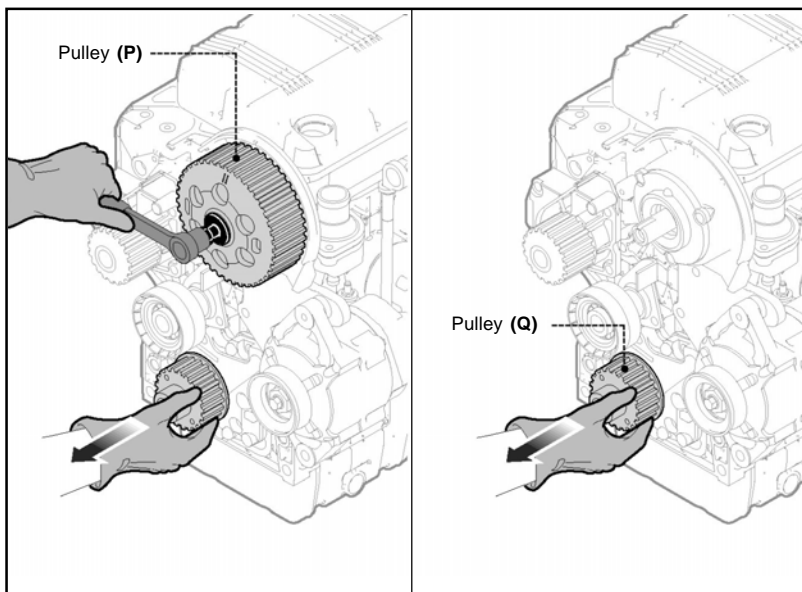

5.4.7 Disassembling the coolant circulation pump

- 1 - Unscrew the water pump fastening screws and nuts.

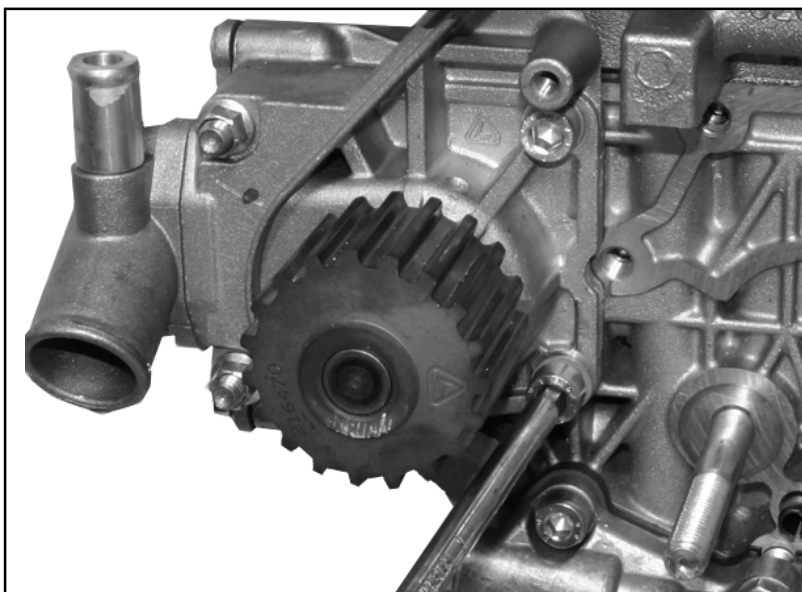

- 2 - Extract the water pump and its gasket.

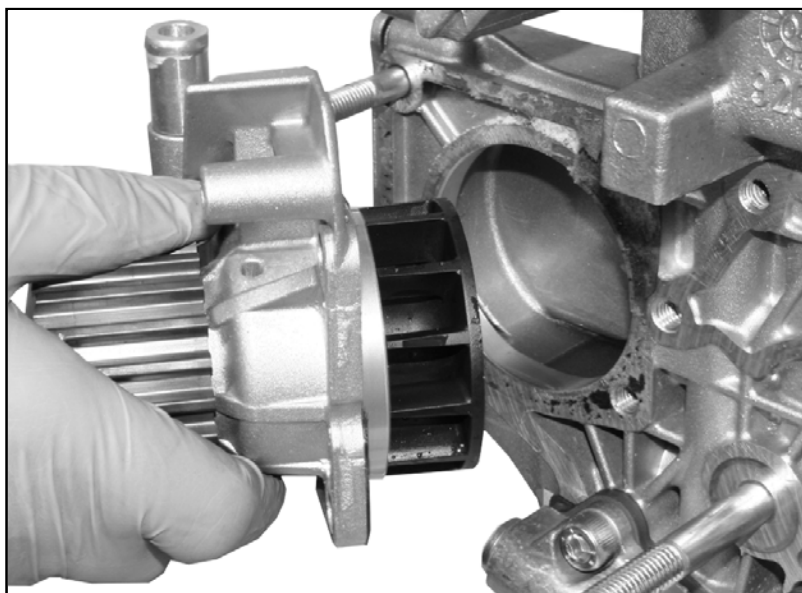

5.4.8 Disassembling the pump scroll

It is possible to disassemble the water pump scroll to inspect the cooling circuit.

1 - To dismount the water pump unscrew the fastening screws.

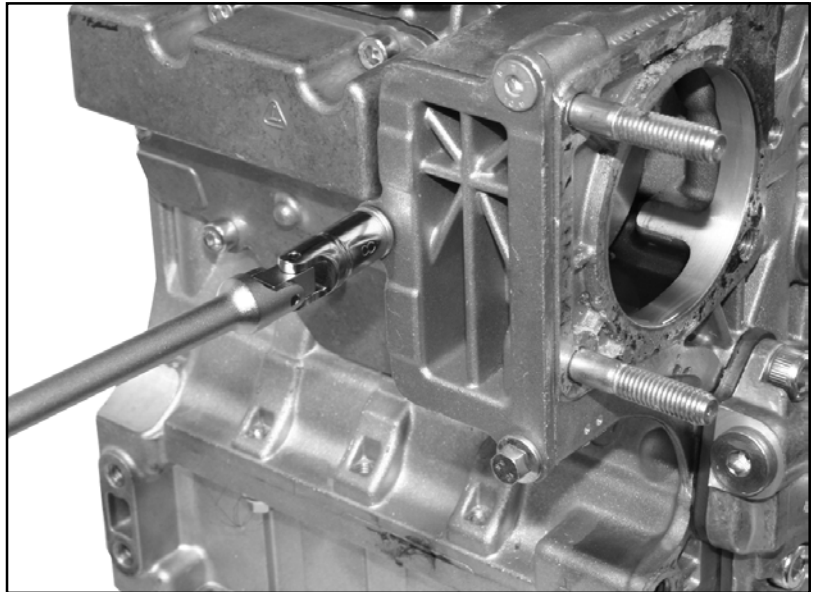

2 - Remove the scroll and the gasket.

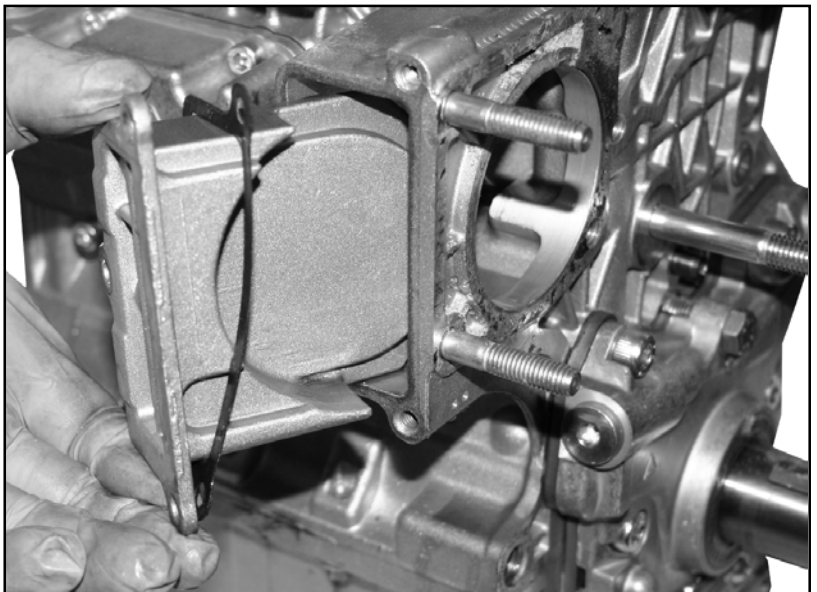

5.5 REMOVING THE CYLINDER HEAD AND COMPONENTS

5.5.1 Disassembling the spark plug

Important

The engine must always be cold before disassembling the spark plugs to avoid damaging the cylinder head thread.

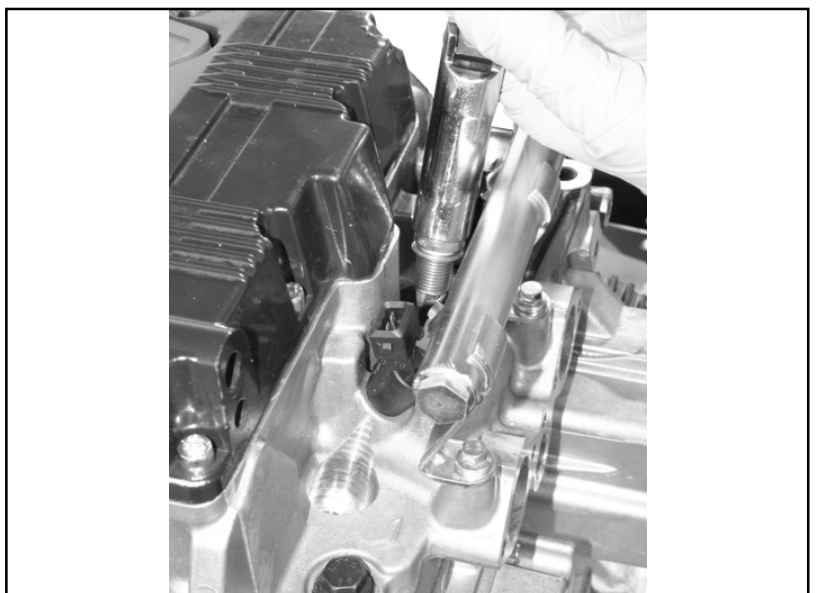

5.5.2 Disassembling the rocker arm cover

- 1 - Loosen the screws in the rocker arm cover.
- 2 - Remove the rocker arm cover.

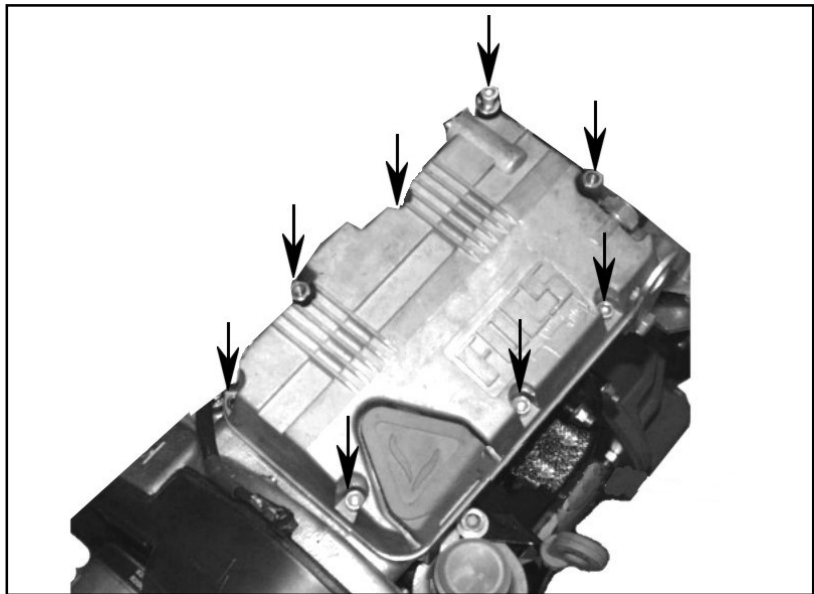

Rocker arm cover components:

- 1 Lubrication ducts of the camshaft and rocker arm pin.
- 2 Lubrication channels of the camshaft and rocker arm pin.
- 3 Rocker arm cover
- 4 Rocker arm cover gasket

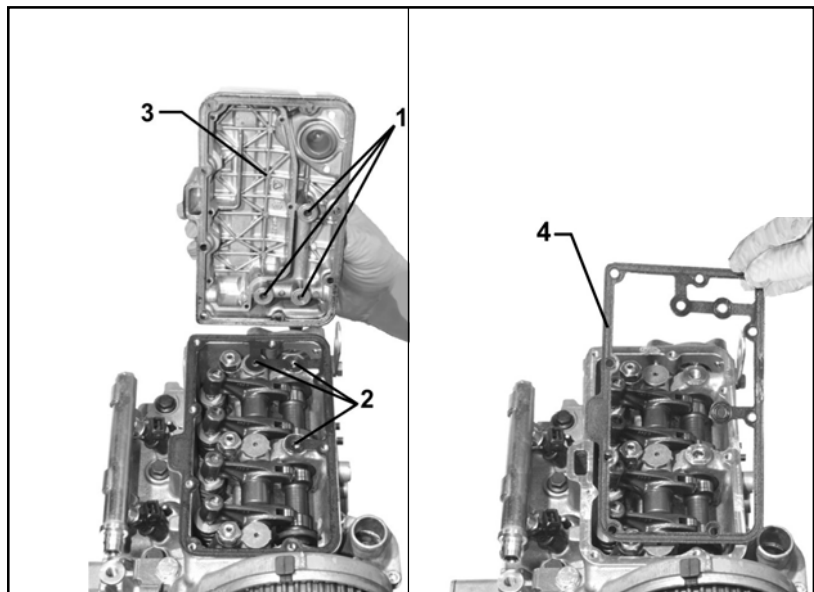

5.5.3 Disassembling the rocker arm assembly

- 1 - Loosen the nuts in the rocker arm supports.

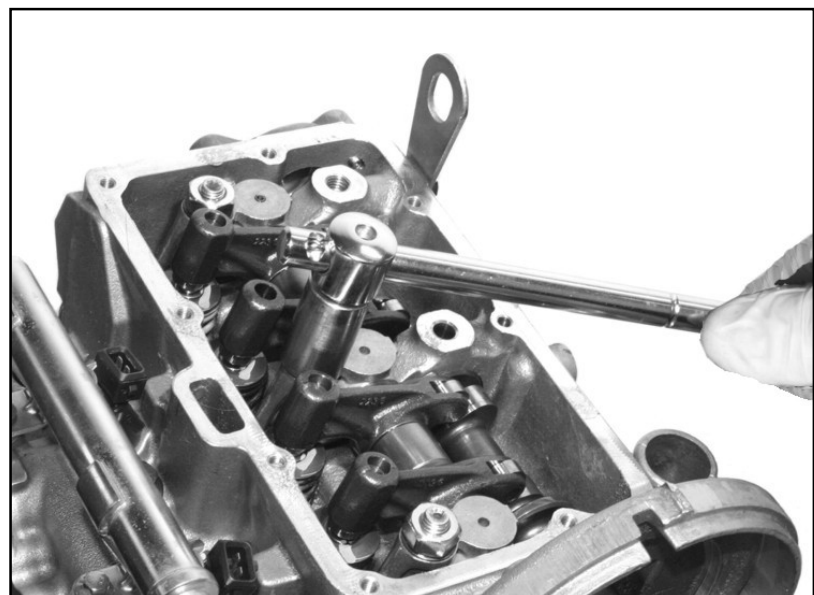

- 2 - Extract the rocker arm assembly along with pin and supports.

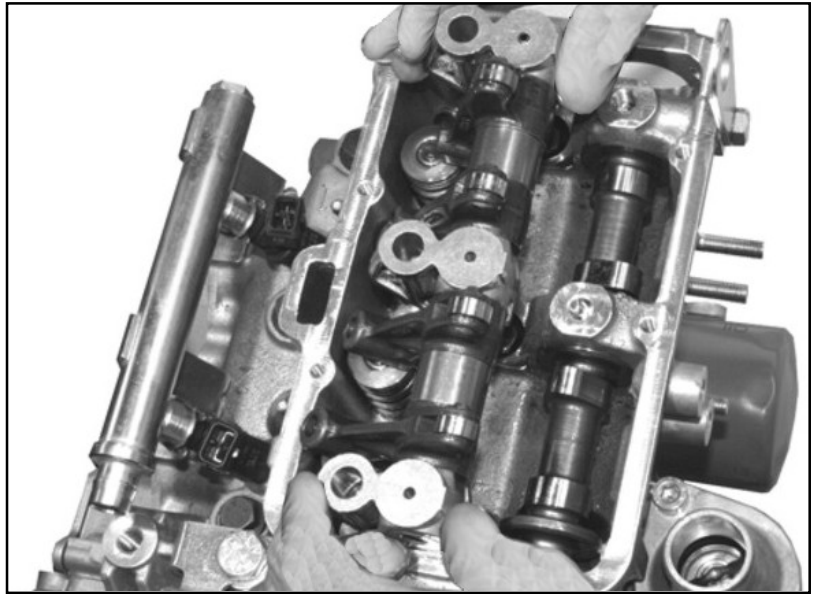

5.5.4 Disassembling the injectors

- 1 - Disconnect the electrical connections from the injectors by squeezing the check spring **(B)**.

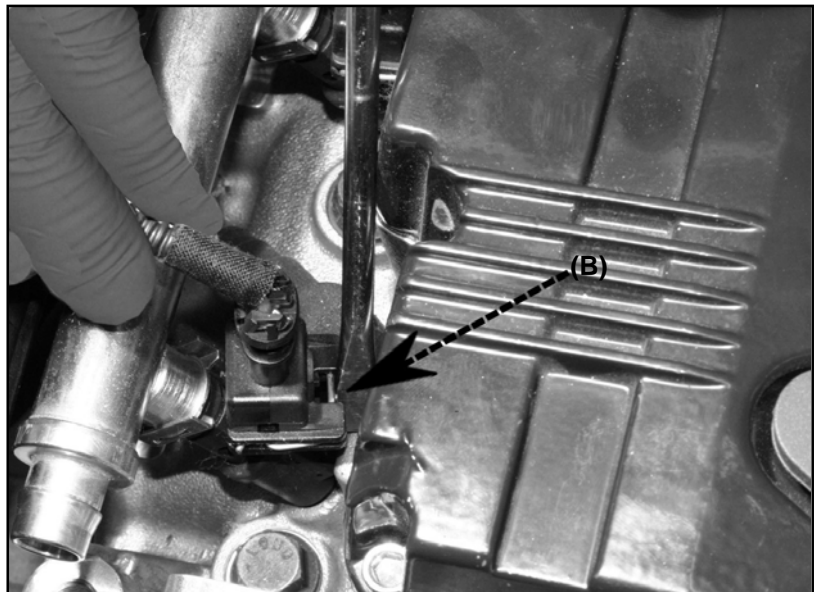

- 2 - Loosen the anchoring bracket screws on the injector supply pipe.



- 3 - Extract the injectors from the cylinder head complete with the mounted supply pipe.

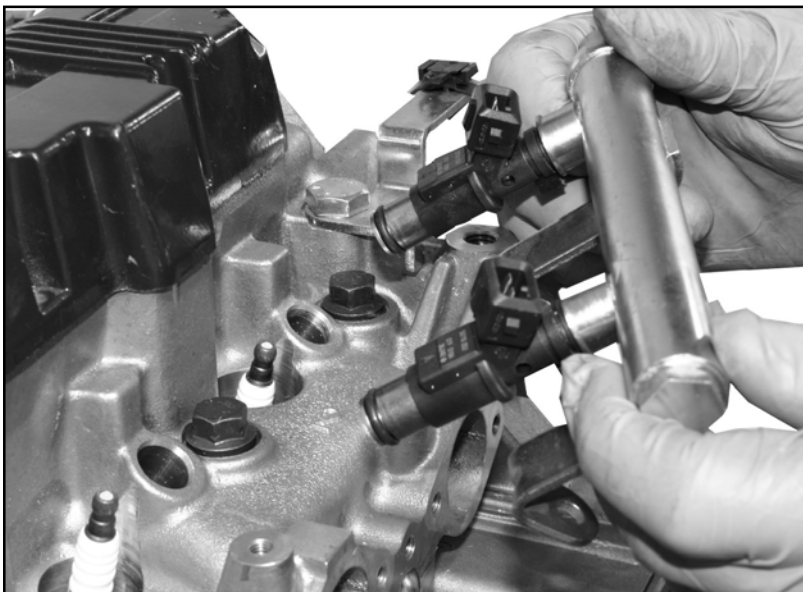

- 4 - With the aid of a screwdriver remove the injector check spring (A), then repeat the operation on the other injector.



- 5 - Disconnect the injectors from the fuel supply pipe.

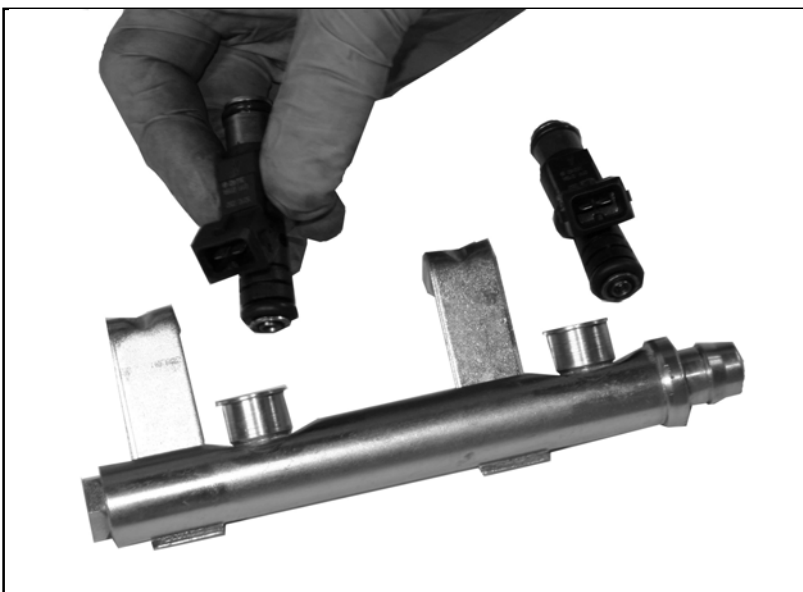

5.5.4 Disassembling the camshaft

- 1- Loosen the screws in the camshaft support.
- 2- Extract the support (A) and the spacer (B).

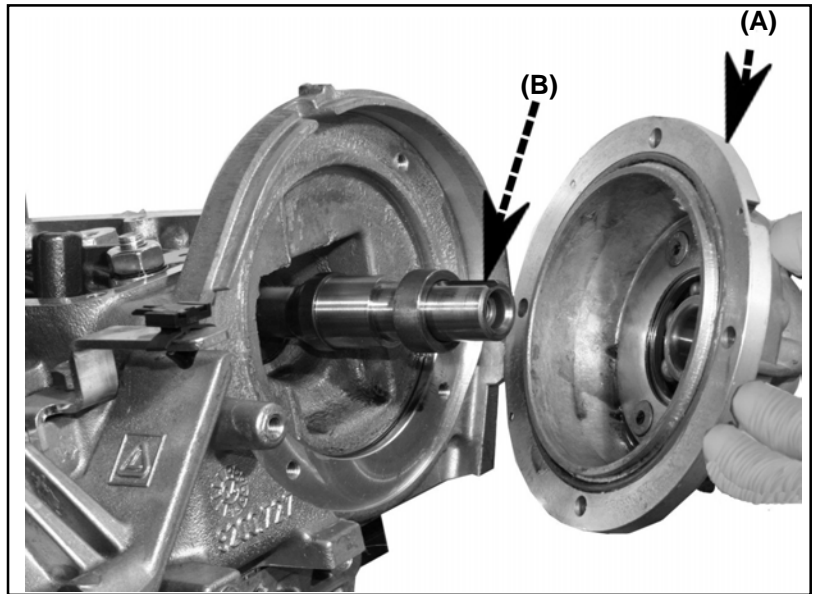

- 3- Remove the cover (X).
- 4- Extract the camshaft (Y) from the cylinder head.

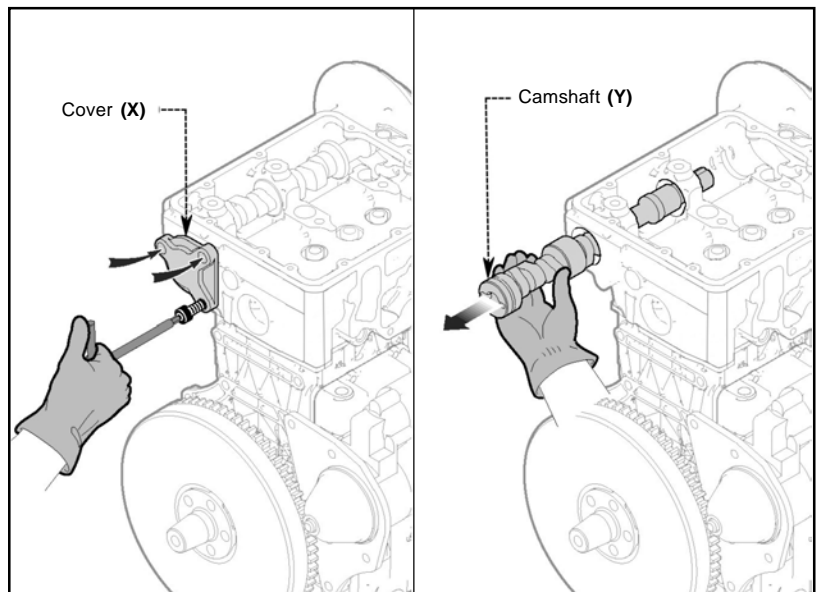

5.5.6 Disassembling the thermostatic valve body

- 1- Loosen the screws.
- 2- Remove the thermostatic valve body.

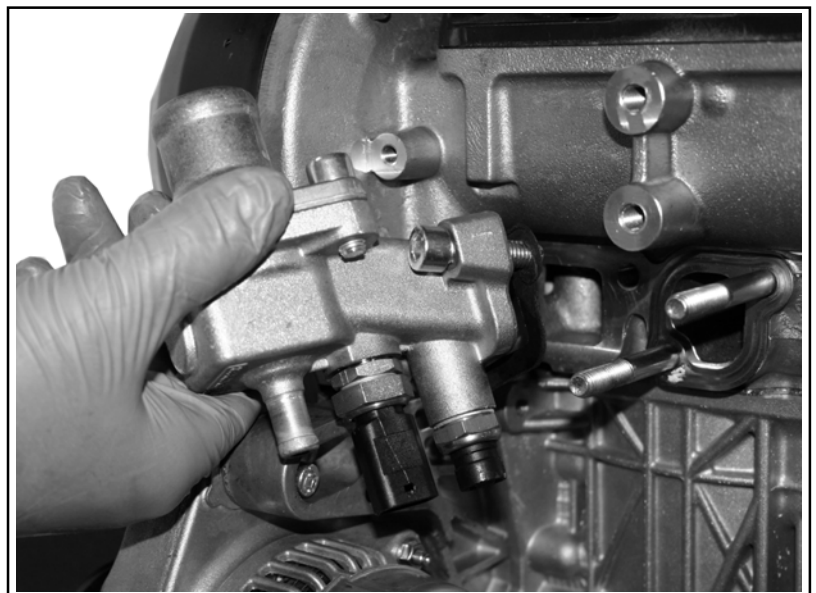

5.5.7 Removing the cylinder head

Important

Do not disassemble while hot to avoid distortion.

- 1 - Loosen the fastening bolts in the cylinder head following the number order shown in the photo.
- 2 - Remove the cylinder head and place it in a container to be washed.
- 3 - Remove the cylinder head gasket.

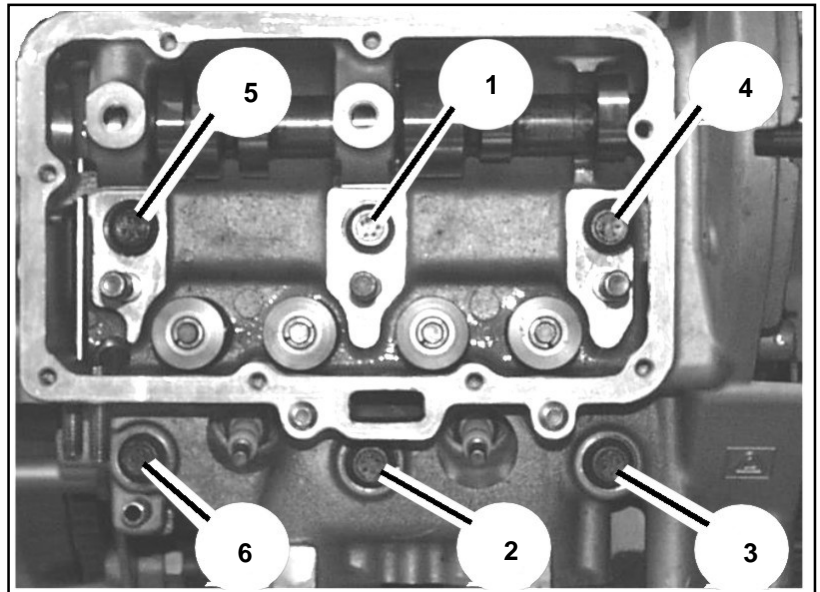

5.6 DISASSEMBLING THE VALVES

- 1 - Place the cylinder head on the workbench.
- 2 - Press down hard on the cup (A), using the special tool.
- 3 - Remove the half collets (B) blocking the cup (A), the spring (C), the collar (D) and the gasket (E).

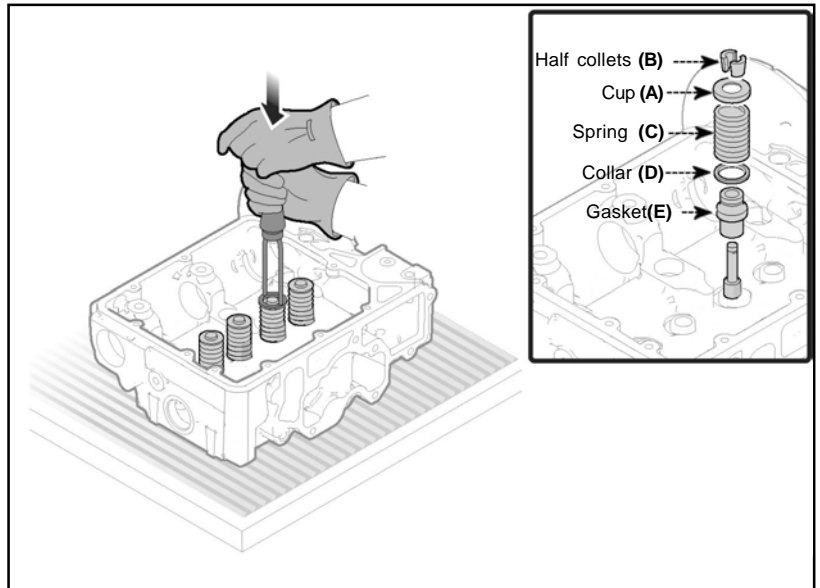

- 4 - Remove the valves (F).

Important

Keep components together during the disassembly phase, in order to be able to reassemble correctly.

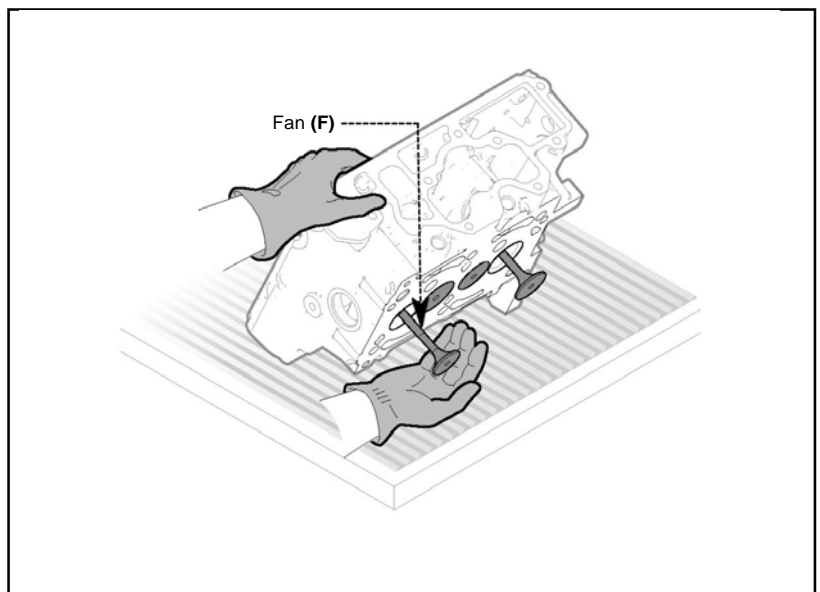

5.7 REMOVING THE CRANK GEAR AND CRANKCASE

5.7.1 Disassembling the flywheel

- 1 - Disassemble the starter motor **(A)**.
- 2 - Install tool «7107-1460-051» to inhibit rotation of the crankshaft.
- 3 - Remove the flywheel **(B)**.

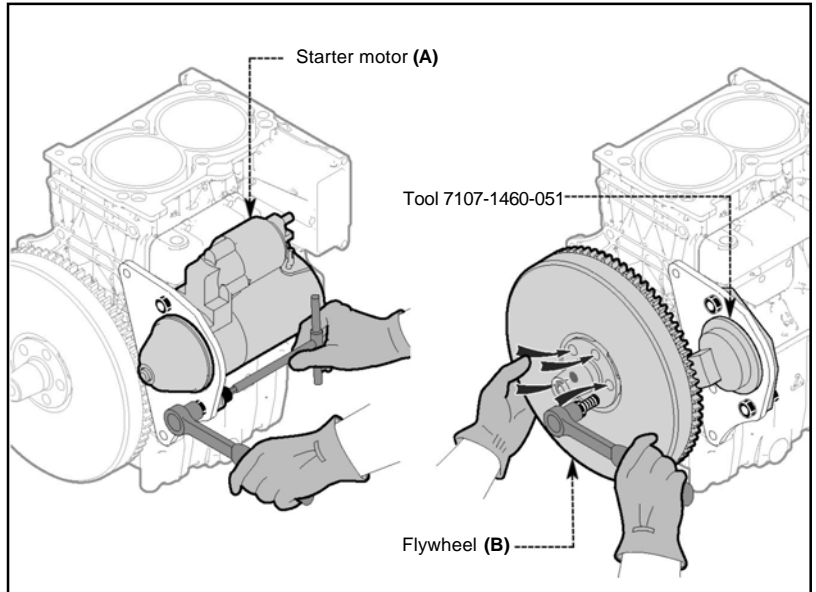

- 4 - Disassemble the starter motor support **(C)**.

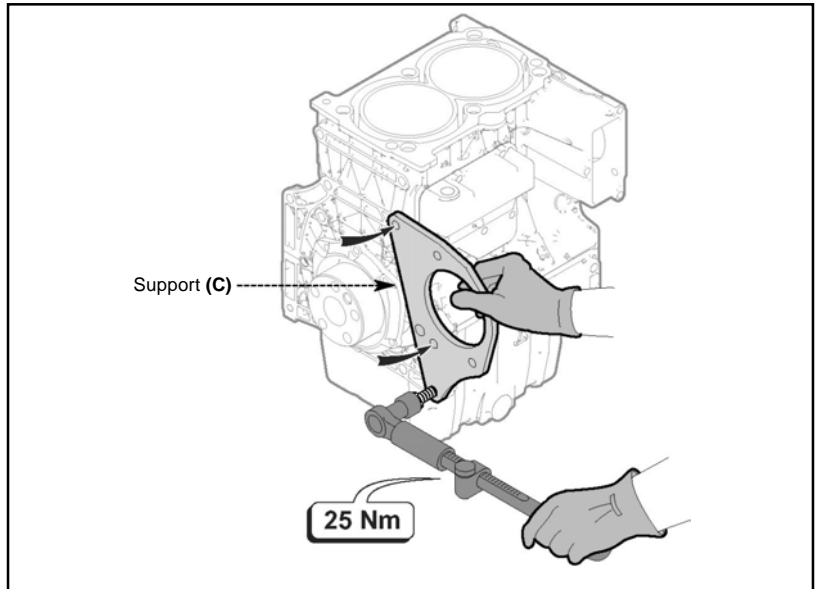

5.7.2 Disassembling the oil pump

Important

The oil pump has been tested before and after assembly. Therefore, do not open unless strictly necessary for reasons of malfunctioning.

- 1 - Remove the support **(D)**.
- 2 - In order to remove the pump the key **(A)** must be passed through the case **(B)**. To do this, position the first cylinder (on the flywheel side) at the top dead centre.

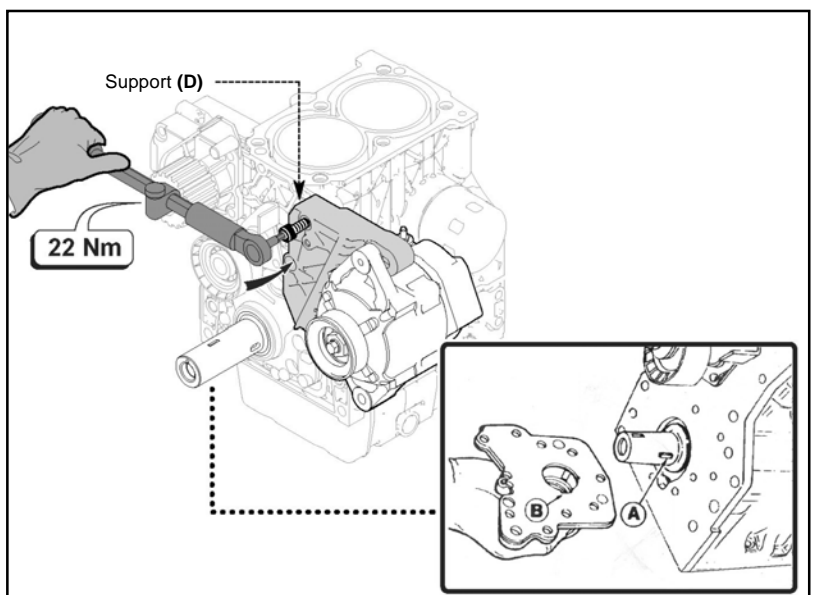

Important

You should in no way try to force removal of the pump, if its activation key is not lined up with the break in the flange.

- 4 - Remove the oil pump (F).
- 5 - Take off the gasket (G).

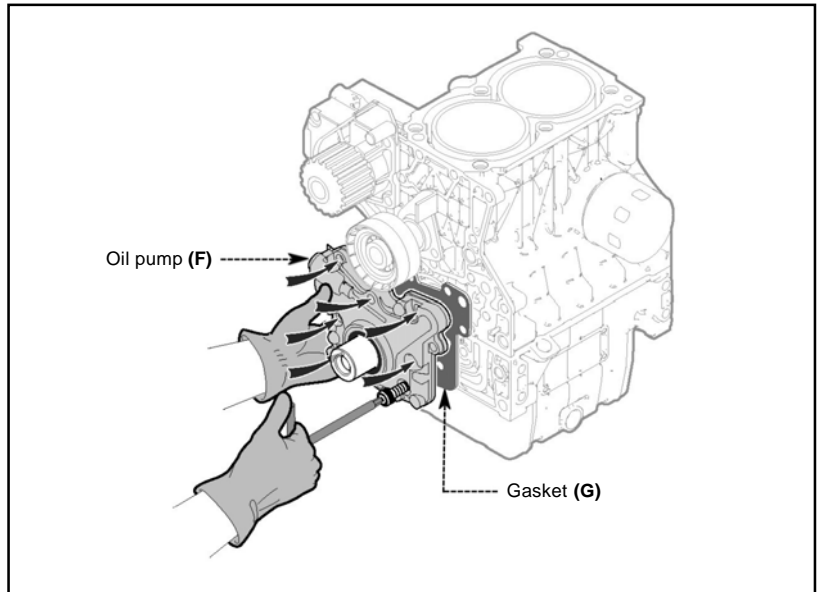

5.7.3 Disassembling the crankcase and crankshaft

- 1 - Remove the flange (H).
- 2 - Take off the gasket (L).

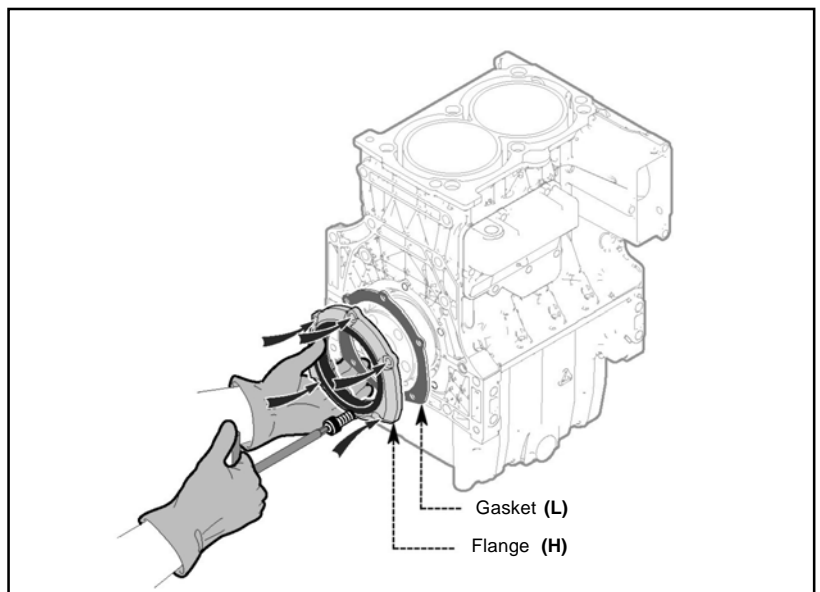

- 3 - Remove the crankcase (M).

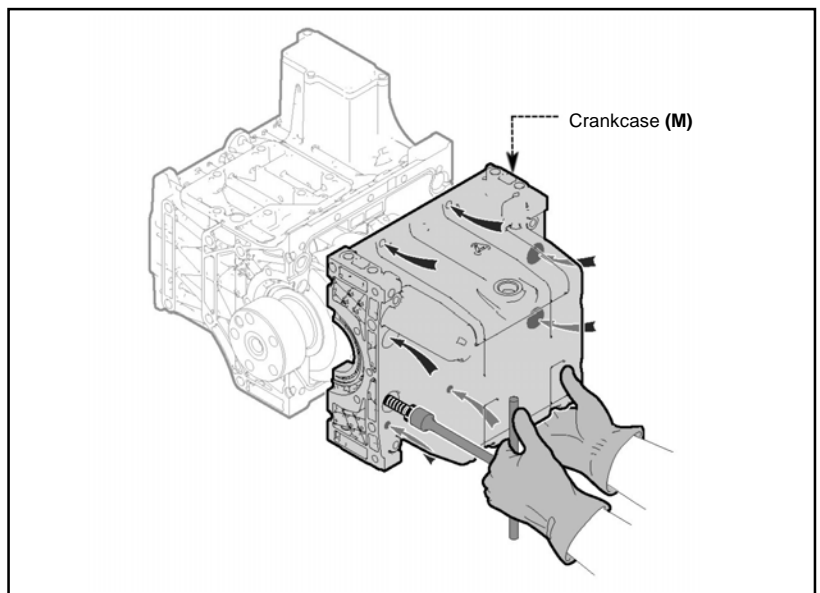

4- Remove the connecting rod cap (N).



Important

Keep all caps together with their own connecting rod.

5- Remove the crankshaft (P) and place it in a container to be washed.



Important

Be careful not to damage the shoulder half-rings during removal.

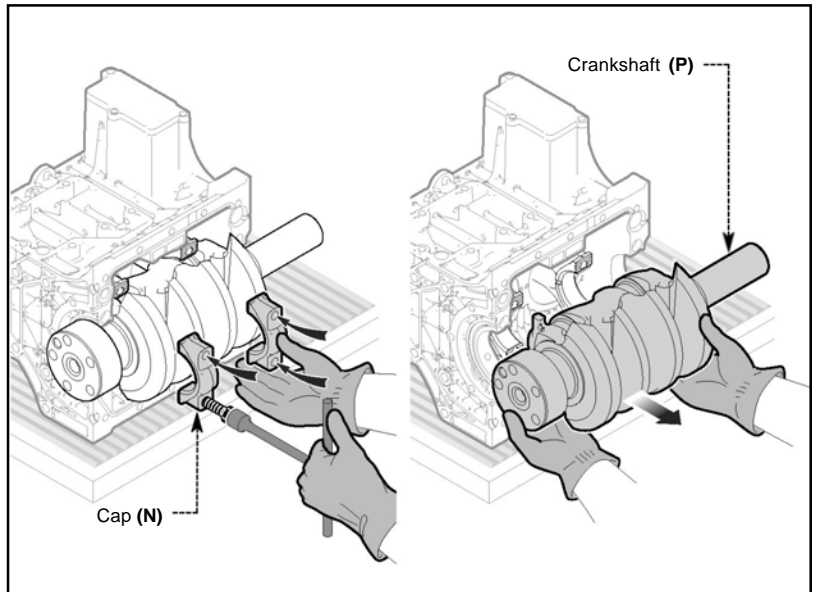

5.7.4 Disassembling the connecting rod and piston

- 1- Extract the connecting rod/piston assembly (Q).
- 2- Remove the crankshaft and connecting rod half bearings.



Caution - Warning

The crankshaft and connecting rod half bearings are made out of special lead-free material, and hence must strictly be replaced with new ones every time they are removed in order to prevent seizure.

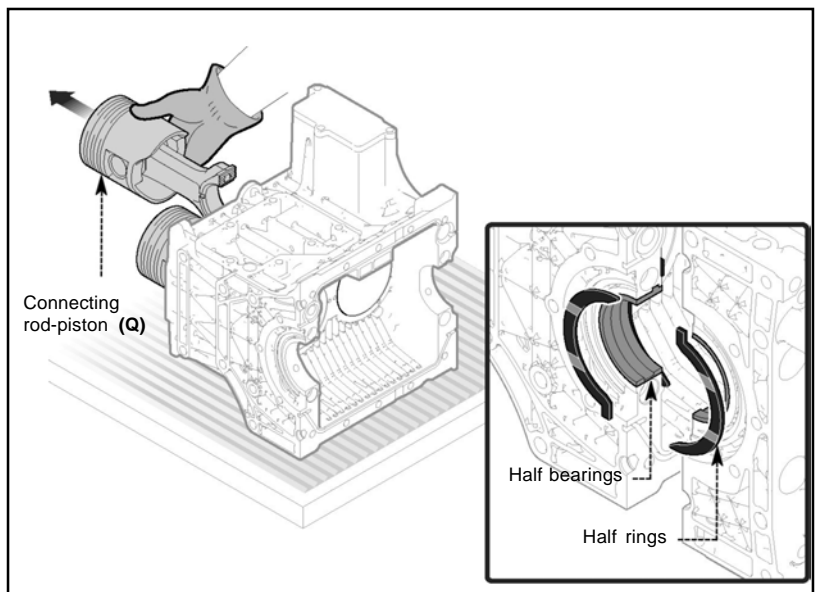

5.8 DISASSEMBLING THE PISTON

- 1- Remove the lock ring (B).
- 2- Extract the wrist pin (C) to separate the piston (D) from the connecting rod (E).



Important

Keep each connecting rod together with its piston and wrist pin.

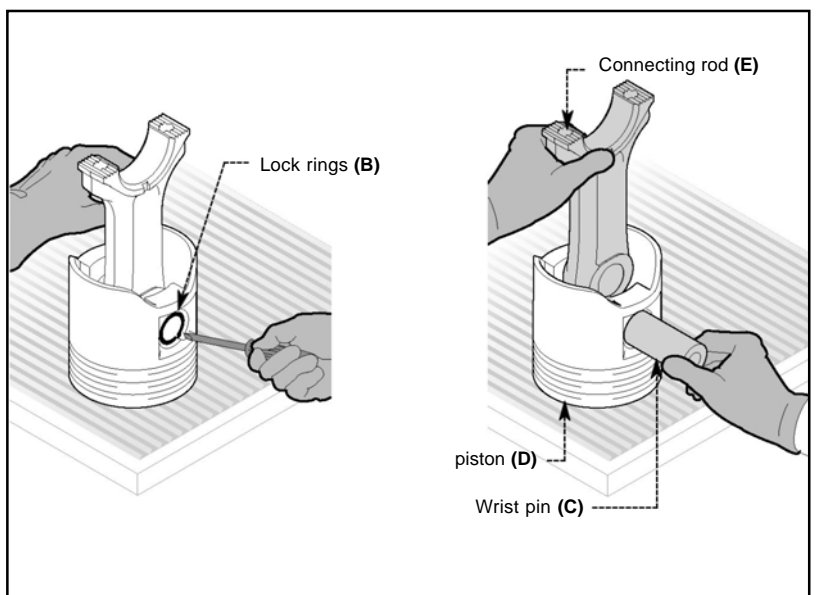

3 - Remove sealing rings (F).

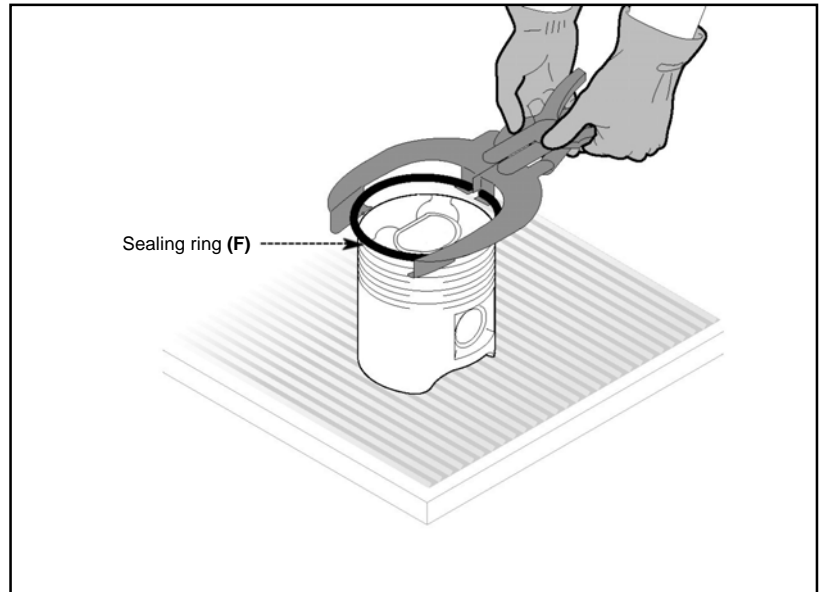

Notes :

.....
.....
.....
.....
.....
.....
.....
.....
.....
.....
.....
.....
.....
.....
.....
.....
.....
.....
.....
.....
.....
.....
.....
.....
.....
.....
.....
.....
.....
.....
.....
.....
.....
.....
.....
.....
.....
.....
.....
.....
.....
.....
.....
.....
.....

6.1 RECOMMENDATIONS FOR OVERHAULS AND TUNING

- Information is given in a logical order in terms of timing and sequence of operations. The methods have been selected, tested and approved by the manufacturer's technical experts.
 - This chapter describes procedures for checking, overhauling and tuning assemblies and/or individual components.
- 
Important
- To locate specific topics, the reader should refer to the index.**
- Before any intervention, the operator should lay out all equipment and tools in such a way as to enable him to carry out operations correctly and safely.
 - The operator must comply with the specific measures described in order to avoid errors that might cause damage to the engine.
 - Before carrying out any operation, clean the assemblies and/or components thoroughly and eliminate any deposits or residual material.
 - Wash the components with special detergent and do not use steam or hot water.
 - Do not use flammable products (petrol, diesel, etc.) to degrease or wash components. Use special products.
 - Dry all washed surfaces and components thoroughly with a jet of air or special cloths before reassembling them.
 - Apply a layer of lubricant over all surfaces to protect them against oxidation.
 - Check all components for intactness, wear and tear, seizure, cracks and/or faults to be sure that the engine is in good working condition.
 - Some mechanical parts must be replaced *en bloc*, together with their coupled parts (e.g. valve guide/valve etc.) as specified in the spare parts catalogue.

6.1.1 Shaft seals

- Clean the shaft thoroughly and make sure that it is not damaged or scored or become oval-shaped in the areas of contact with the seals.
- Lubricate the seal lips, and pointing them in the right direction, place them in their seat using a special pad.
- Do not use a hammer directly on the gaskets during assembly, to avoid damaging them.
- Be careful not to damage the gaskets while joining them to the shaft.

6.1.2 O-rings

- Lubricate the seal before introducing it to its seat.
- Avoid «rolling» the gasket during the attachment phase.

6.1.3 Bearings

- Use special extractors or plugs to remove bearings.
- Clean the bearings thoroughly. Check their condition and, if they are fully intact, lubricate all over, otherwise replace with original spares.
- Do not use a hammer directly on the bearings during assembly, to avoid damaging them.

6.2 OVERHAULING THE CRANK GEARS AND CRANKCASE

6.2.1 Overhauling cylinders and pistons

Before deciding what kind of overhaul needs to be done, it is important to carry out a dimensional check and verify the correspondence of cylinders, pistons, sealing rings, crankshaft and connecting rods.

6.2.2 Dimensional check and overhaul of cylinders

- 1 - Place the engine block on the workbench.
- 2 - Using a dial indicator, measure the diameter at points 1-2-3 (see figure).
- 3 - Rotate the dial indicator 90° and re-measure.
- 4 - Check the table to identify the class of the values detected. The class letter is engraved on the engine block surface (see figure). If ovalization or wear is greater than 0.05mm, the cylinder must be ground.

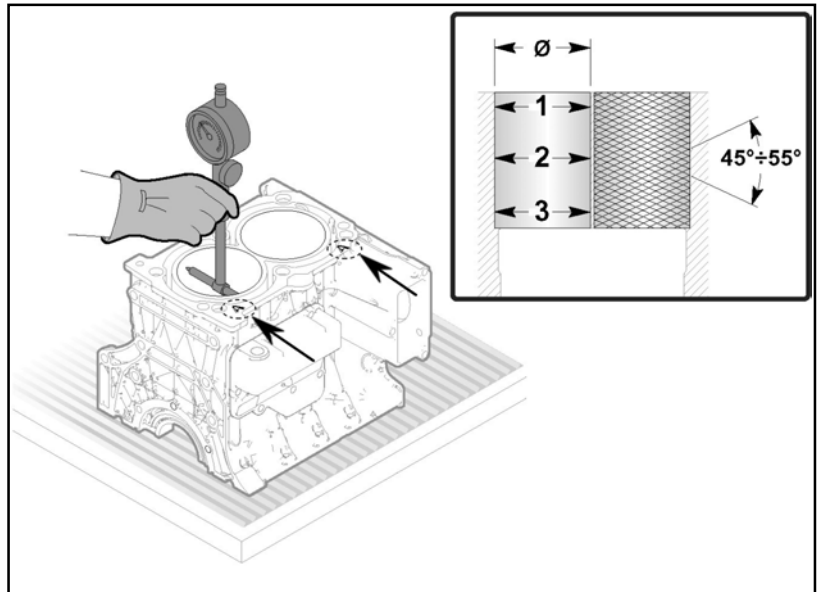

Important

- The increases recommended by the manufacturer for the cylinder head are 0.5 and 1mm.
- When grinding make sure that the working angle is 45-55° and that the average roughness is Ra=0.5-1.
- Do not sand the internal surfaces of the cylinders using emery cloth.
- Protect the contact surfaces with lubricant oil, to prevent them from rusting.

The table shows the reference values and their class (only applies to new engines).

Table of cylinder-piston classes and dimensions

Dimension class	Ø Cylinders (mm)	Ø Pistons (mm)	Clearance (mm)
A	71,990÷72,000	71,940÷71,950	0,04±0,06
B	72,000÷72,010	71,950÷71,960	

Important

Pistons with nominal diameter are supplied only in class (A) spares. Those uprated by 0.5 and 1mm have the uprating reference (ø72.5 and ø73) engraved on the upper part of the piston (crown).

6.2.3 Dimensional check and overhaul of pistons

- 1 - Clean the piston thoroughly.
- 2 - Using a micrometer, measure the piston 9mm from the base of the skirt.
- 3 - Check the table to identify the class of the values detected. The class letter is engraved on the piston crown. If clearance between cylinder and piston is greater than 0.06mm, the piston and sealing rings must be replaced.

Important

Before replacing the pistons, check that the weight difference between the two integral preassembled connecting rod-piston-rist pin assemblies does not exceed 6g to prevent weight imbalances.

Protect the contact surfaces with lubricant oil, to prevent them from rusting.

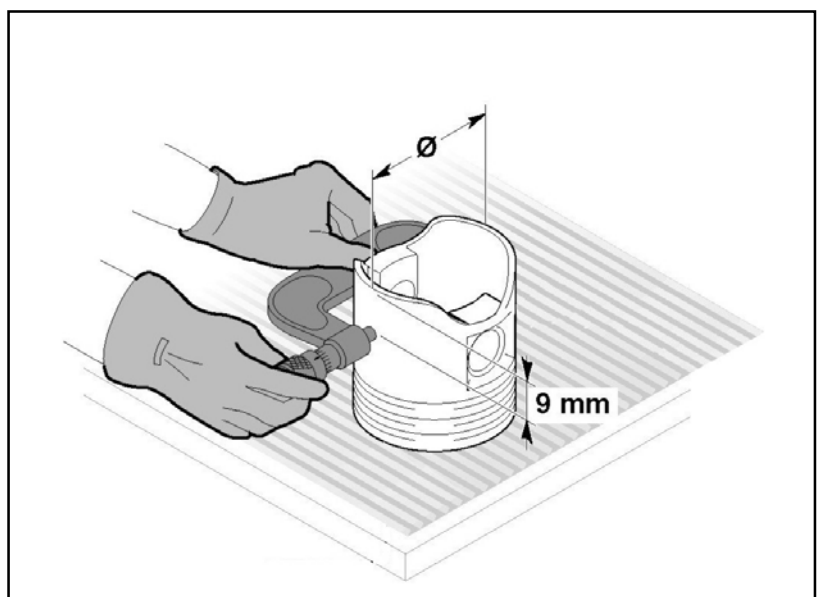

6.2.4 Dimensional check of sealing rings

- 1 - Place a sealing ring in the cylinder and measure the ring end gap using a thickness gauge (**H**).
- 2 - Repeat for all the sealing rings. If the ring end gap does not correspond to the values indicated in the table, replace the sealing ring with an original spare.

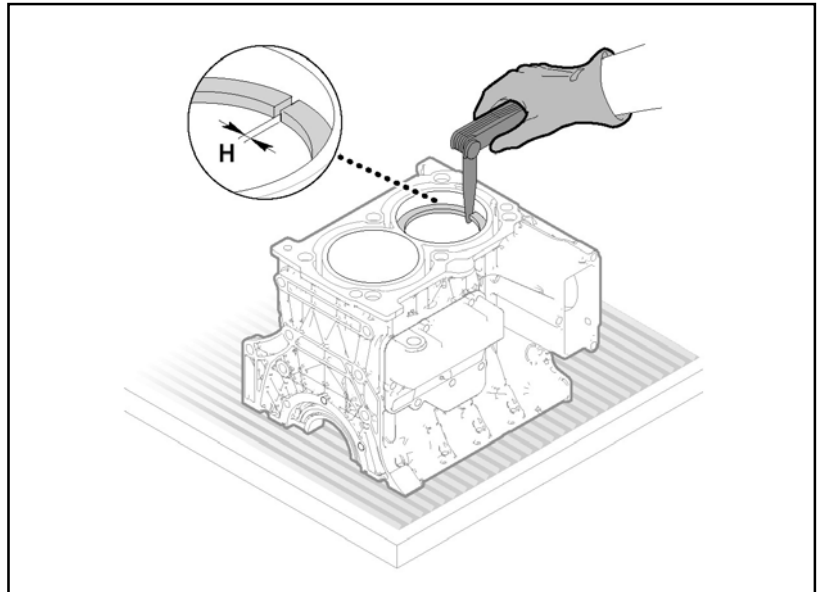

Dimensional table of sealing rings

Sealing rings	Ring end gap (mm)	Wear and tear limit (mm)
1°	0,25±0,45	1,0
2°	0,25±0,45	
3°	0,20±0,45	

- 3 - Put the sealing rings on the piston in the order shown in the figure.

Important

Place the sealing rings with the markings facing up towards the piston crown.

- 4 - Using a thickness gauge, measure the clearance of each sealing ring with its seat. If clearance does not correspond to the values shown in the table, replace the sealing rings with original spares.

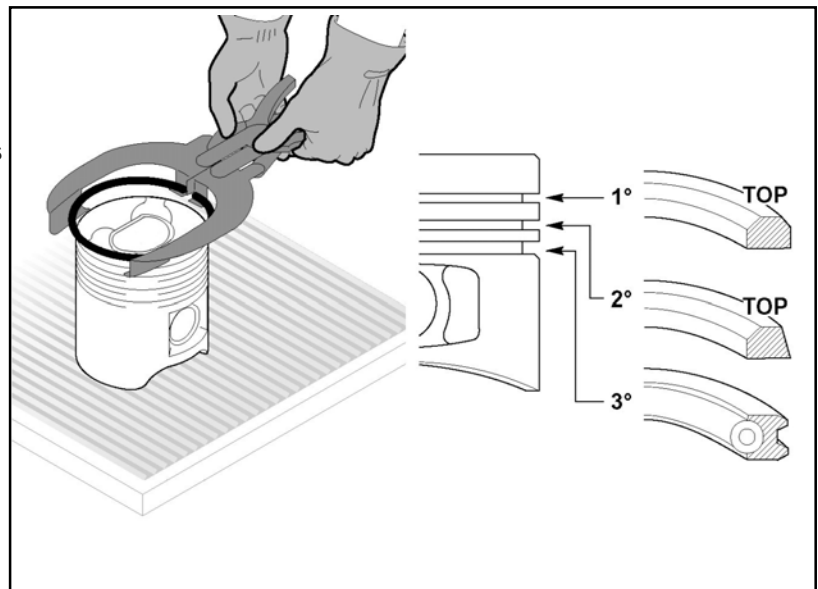
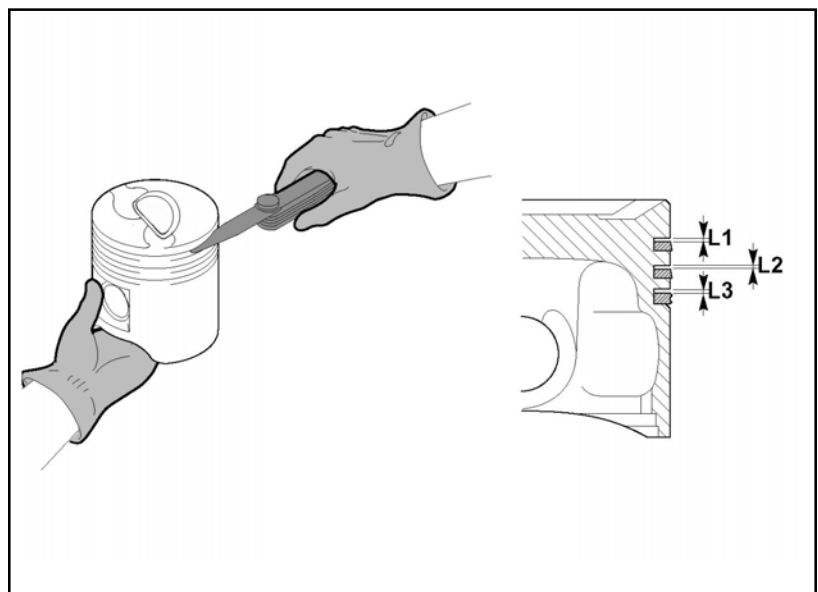

Table of sealing ring/piston clearance

Sealing rings	Clearance (mm)
1°	L1= 0,090±0,125
2°	L2= 0,050±0,085
3°	L3= 0,040±0,075

Important

- Sealing rings cannot be replaced separately.
- Protect the contact surfaces with lubricant oil, to prevent them from rusting.



6.2.5 Dimensional check and overhaul of crankshaft

- 1- Wash the crankshaft thoroughly using suitable detergent.
- 2- Introduce a pipe cleaner into the lubrication ducts to remove any residual dirt.
- 3- Blow compressed air into the points indicated to free the ducts from oil.
- 4- Check the surfaces of the main journals and crank pins for wear and tear to see whether grinding is necessary.
- 5- Using a micrometer, measure the diameter of the main journals (**A1**) and crank pins (**B1**).
- 6- Using a dial indicator, measure the inside diameters of the crankshaft (**A2**) and connecting rod (**B2**) half bearings .

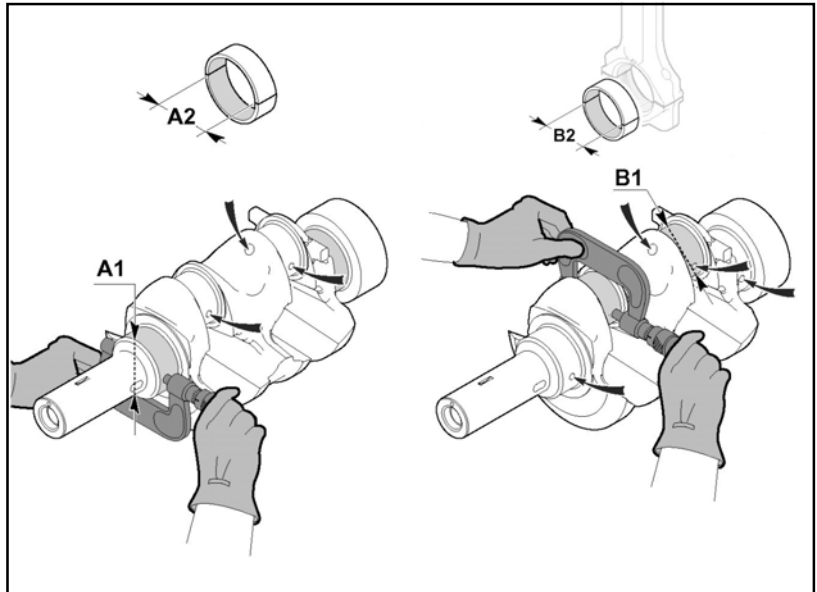

Table of diameters of crankshaft and connecting rod half bearings

Réf.	Dimensions (mm)	Wear and tear limit (mm)	Clearance (mm)	Max clearance (mm)
A 1	47,984÷48,000	47,95	A 2-A 1=0,025÷0,087	0,12
A 2	48,025÷48,071	48,1		
B 1	39,984÷40,000	39,95	B 2-B 1=0,021÷0,066	0,10
B 2	40,021÷40,05	40,08		

Tableau agrandissements demi-bagues d'épaulement

Half rings	Dimensions (mm)		Clearance
	A	B	
Standard	22,787÷22,920	23,050÷23,100	C = A - B 0,130÷0,313
1st increase	22,987÷23,120	23,250÷23,300	
2^a increase	23,087÷23,220	23,350÷23,400	
3^a increase	23,187÷23,320	23,450÷23,500	

Important

- Half bearings cannot be replaced separately.
- If the crankshaft needs to be ground, establish the diameters of the connecting rod and crank pins, in order to choose the matching measurements available of connecting rod and half bearing spare parts (see «Table of diameters of crankshaft and connecting rod half bearings»).
- When grinding the crankshaft it is possible to downrate the crankshaft and connecting rod pins by 0.25mm and 0.5mm.
- When grinding the crankshaft it is also necessary to consider grinding the sides (shoulder) to be able to choose uprated half-ring replacements (see «Table of uprated shoulder half-rings»).

Important

Protect the contact surfaces with lubricant oil, to prevent them from rusting.

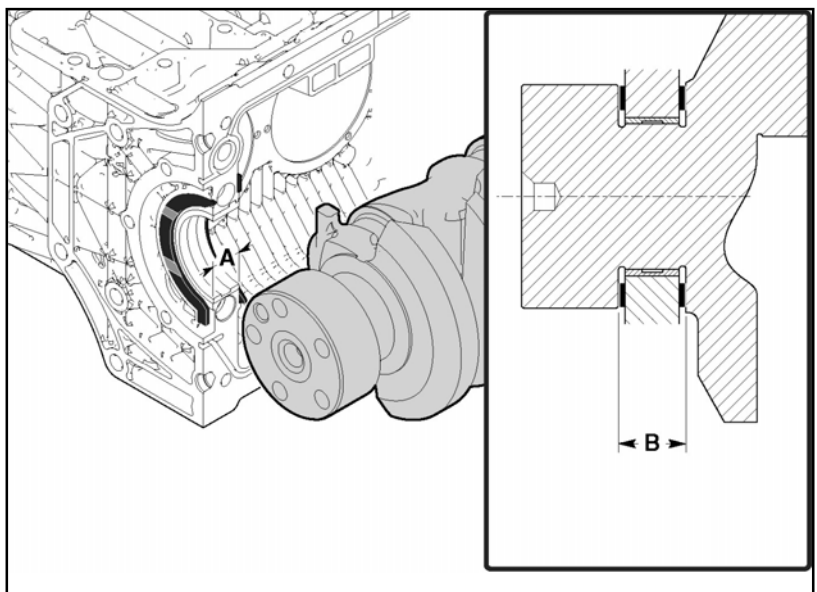

6.2.6 Dimensional check and overhaul of connecting rods

- 1 - Check that the contact surfaces are perfectly clean and intact.

Caution – Warning

The crankshaft and connecting rod half bearings are made out of special lead-free material, and hence must strictly be replaced with new ones every time they are removed in order to prevent seizure.

- 2 - Assemble the cap (N) onto the connecting rod big end together with the new half bearings and tighten the screws to a torque of 40 Nm.
- 3 - Using a dial indicator, measure diameters C - B.

Important

- Make sure that the connecting rod and crankshaft half bearings are properly matched (see «Table of crankshaft and connecting rod half bearing dimensions»).
- The half-bearings are supplied smaller than the nominal dimensions, by 0.25 and 0.5mm.
- If the diameter of the connecting rod small end (B) does not match the diameter of the wrist pin, the small end bearing must be replaced to achieve the correct fit (see «Table of connecting rod dimensions»).
- Protect the contact surfaces with lubricant oil, to prevent them from rusting.

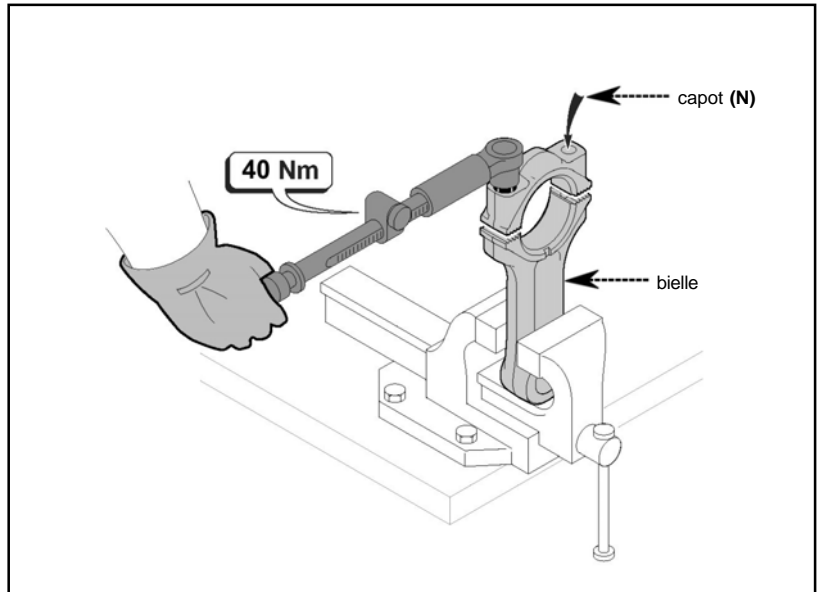
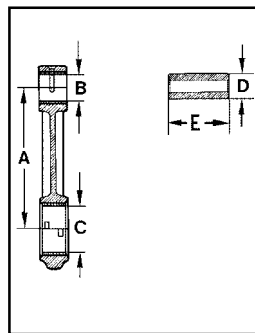

Table of connecting rod dimensions



Réf.	Dimensions (mm)	Clearance (mm)	Wear and tear limit (mm)
A	106,98±107,02	B-D 0,015±0,03	0,06
B	18,015±18,025		
D	17,995±18		
C	40,021±40,05		
E	50,9±51,1		

6.2.7 Checking parallelism of the connected rod axes

- 1 - Insert the wrist pin into the small end of the connecting rod.
- 2 - Use a dial indicator to check that there is parallelism between the small end and big end axes.

Parallel deviation, measured at the very tip of the wrist pin, must not exceed 0.015-0.03mm.

If parallel values do not correspond to those indicated, replace the connecting rod with an original spare.

- 3 - Before replacing the connecting rods, check that the weight difference between the two integral preassembled connecting rod-piston-wrist pin assemblies does not exceed 6g to prevent weight imbalances.
- 4 - After carrying out all checks and overhauls, remount the connecting rods, pistons and sealing rings (see «Pre-assembly of sealing rings - pistons» and «Pre-assembly of connecting rods - pistons»).

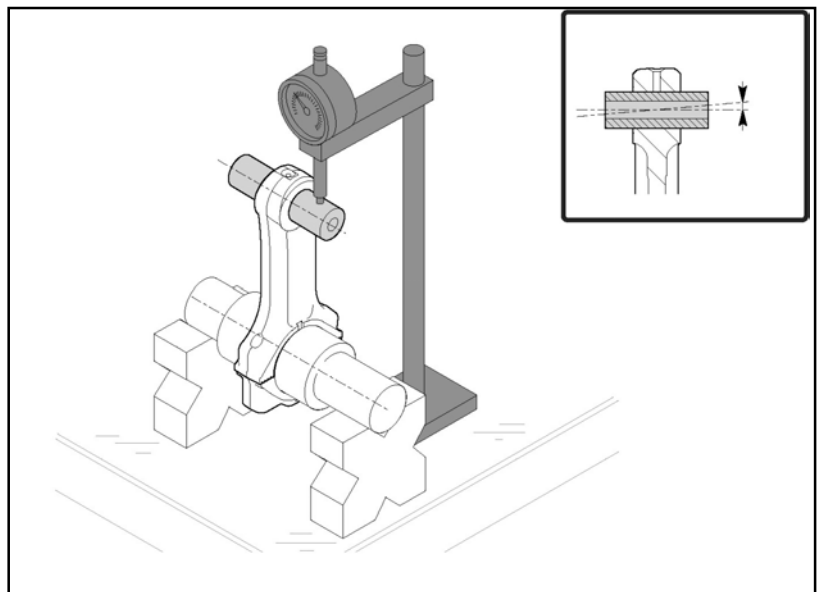

Important

Protect the contact surfaces with lubricant oil, to prevent them from rusting.

6.2.8 Checking and overhauling the oil pump

Disassemble the oil pump before checking or overhauling. See «Disassembling the oil pump» for the correct procedure.

- 1 - Remove the plate (A).
- 2 - Remove the O-ring (B).
- 3 - Remove the sealing ring (C) from the flange and clean the seat.
- 4 - Unscrew the plug (D) and extract the gasket (E), the spring (F) and the valve (G).
- 5 - Disassemble the rotors (H).
- 6 - Blow compressed air into the valve seat to clean it.
- 7 - Thoroughly clean all the components.
- 8 - Check that the rotor working surfaces (H) on the pump case are perfectly intact and clean and are not worn. If there is severe wear, replace the oil pump with an original spare.
- 9 - Mount the rotors (H) with the reference notches facing upwards so that they are visible.
- 10 - Using a thickness gauge, measure the clearance between the rotor teeth.
If clearance is above the 0.25mm limit for wear, replace the rotors with original spares.
- 11 - Check that the contact surfaces are perfectly clean, intact and not deformed.
- 12 - Mount a new O-ring (B).

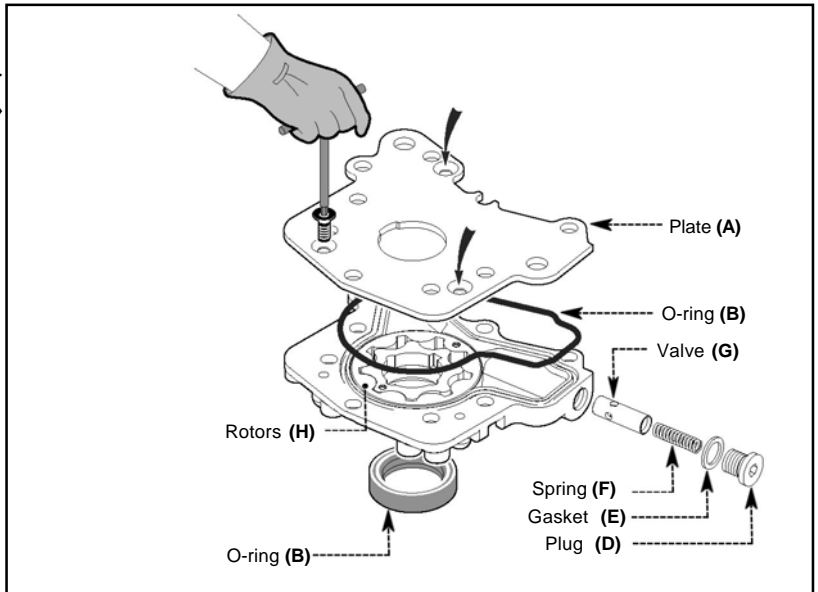

Important

The O-ring must always be replaced with an original spare part whenever the pump is disassembled.

- 13 - Replace the plate (A) and put in the screws (L).
- 14 - Tighten the screws (L) to a final torque of 10 Nm.
- 15 - Measure the length of the spring (F). If the length of the spring is not between 27.50 and 27.75mm, replace it with an original spare.
- 16 - Replace the valve (G), the spring (F), the gasket (E) and the plug (D).
- 17 - Fill the sealing ring (C) with grease and lubricate the rim with oil.
- 18 - Mount the new sealing ring (C) using a special tool.

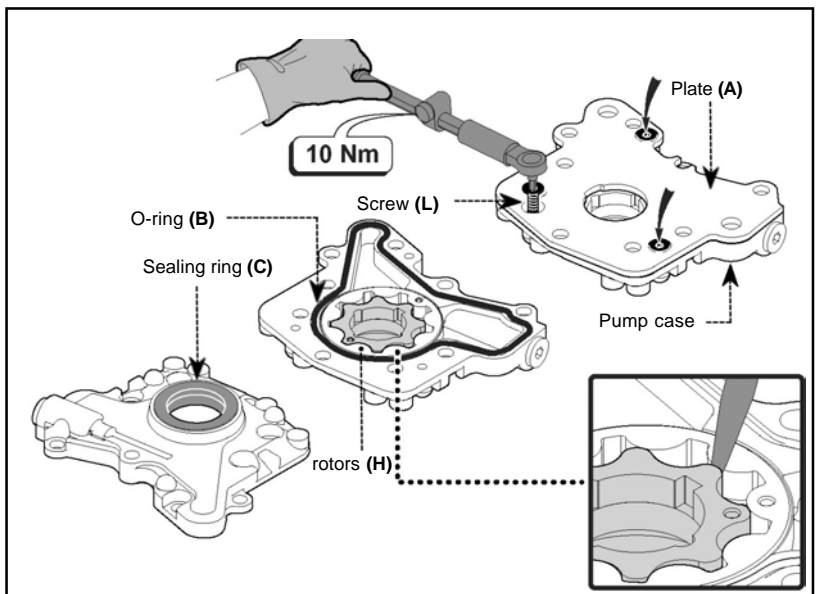

Important

Given the particular function played by this sealing ring, it is important to use only original spares.

6.2.9 Overhauling the decanting device

In order to overhaul the decanting device, it is necessary to disassemble the starter motor.

- 1 - Loosen the clamp and extract the pipe **(A)**.
- 2 - Remove the cover **(B)**.
- 3 - Thoroughly clean the inside of the cover and blow on compressed air to eliminate all residues.
- 4 - Check that the decanting device is intact and, if necessary, replace it with an original spare.
- 5 - Slip on a new gasket **(D)**.
- 6 - Replace the cover **(B)** and tighten the screws to a final torque of 10 Nm.
- 7 - Replace the pipe **(A)** and fasten it using the clamp.
- 8 - Install the starter motor and tighten the screws to a torque of 45 Nm.

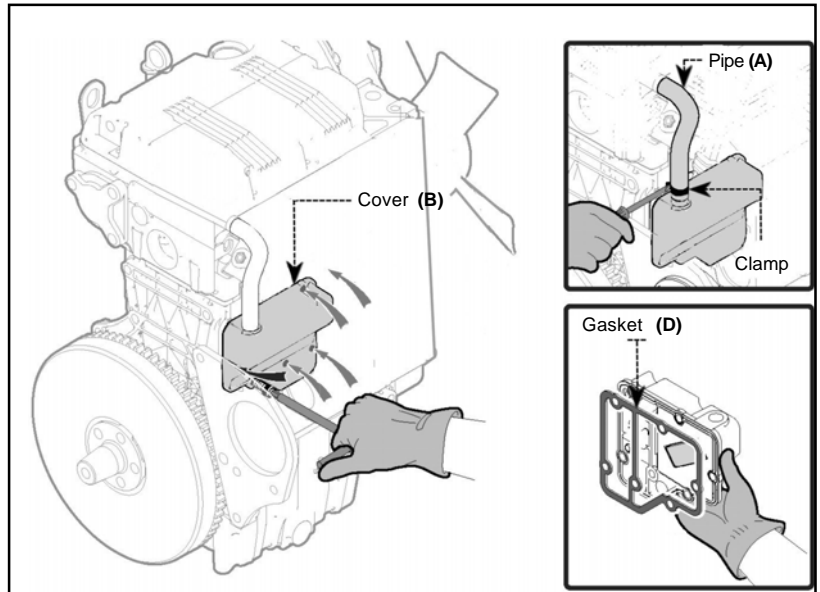

6.3.5.3 OVERHAUL OF CYLINDER HEAD AND COMPONENTS

6.3.1 Checking and overhauling the cylinder head

- 1 - Place the cylinder head on a surface plate and position it with the corners on the stud bolts.
- 2 - Using a dial indicator, make sure the cylinder head is level.

Important

If the level deviation is greater than 0.10mm, the cylinder head must be ground, removing no more than 0.2mm.

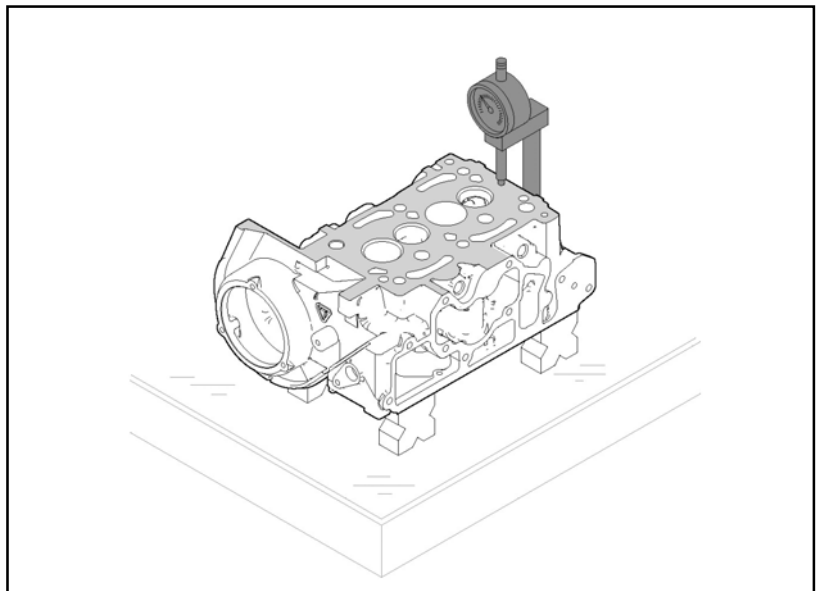

6.3.2 Checking and overhauling the valves

In order to carry out a control of the valves, it is necessary to remove them from the cylinder head. See «Disassembling the valves» for the correct procedure.

- 1 - Use a gauge to measure the length of the springs (see «Table of dimensions for springs – valve stems - valve guides»).

Table of dimensions for springs – valve stems – valve guides

Réf.	Dimensions (mm)	Clearance (mm)	Wear and tear limit (mm)
Ø x	7,005÷7,020	X - Y 0,015÷0,06	0,10
Ø y	6,960÷6,990		
Z	37,5÷39,8		
W	0,5÷0,8		
J	1,6÷1,7		

If the length does not correspond to the value shown, replace the springs with original spares.

- 2 - Use a micrometer to measure the diameters of the valve stems and a dial indicator to measure valve guide diameters (see «Table of dimensions for springs – valve stems – valve guides»). If the diameters do not correspond to the values show, replace the valves and guides with original spares.



Important

Take measurements in several places in order to detect possible ovalization and/or severe wear.

- 3 - Thoroughly clean the valves and their seats.
- 4 - Measure the width of the seal (**J**) for each valve and the indentation (**W**) from the flat part of the cylinder head (see «Table of dimensions for springs – valve stems – valve guides»). If the dimensions do not correspond to the values shown, replace with original spare parts.
- 5 - Use a pointed tool to take out the valve seats.
- 6 - Remove any debris, clean the valve seat holder carefully and scrape the mouth.
- 7 - Lubricate the new valve seats and put them into the holder manually.
- 8 - Use the special tool to put the valve seats into the holder.
- 9 - Slide the valves into their seats.

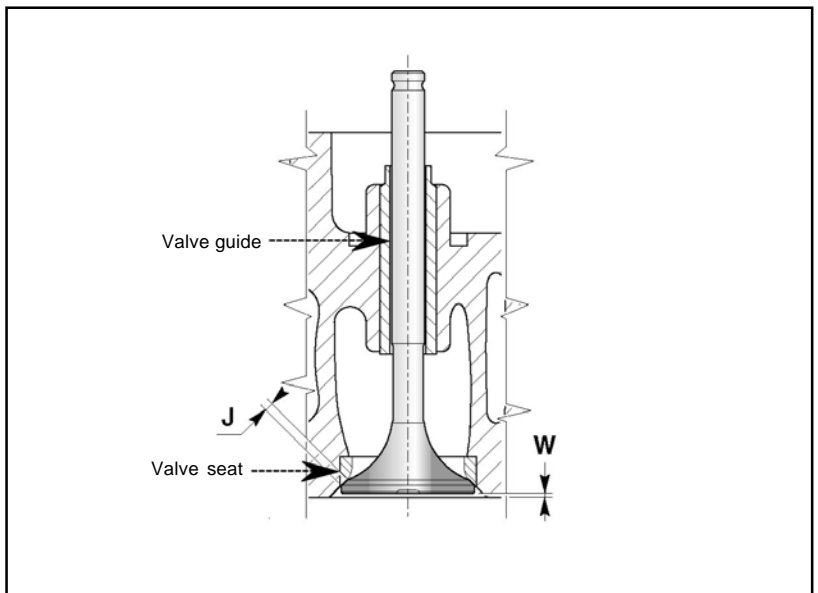
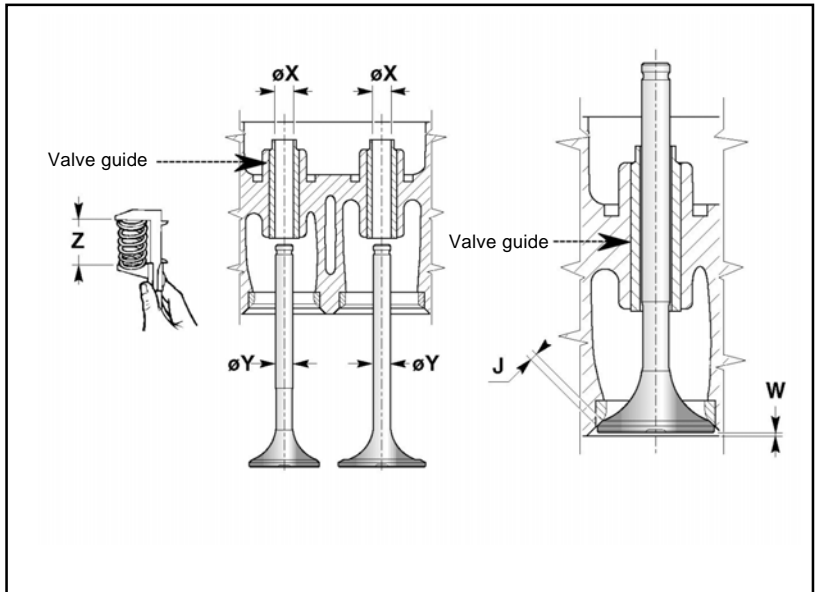

- 10 - Measure the degree of indentation of each valve from the flat part of the cylinder head (see «Table of dimensions for springs – valve stems – valve guides»). If the dimensions do not correspond to the values shown, grind each valve into its seat.



Important

Protect the contact surfaces with lubricant oil, to prevent them from rusting.

- 11 - Assemble the valves (see «Assembling the valves»).

6.3.3 Checking and overhauling the rocker arm pin

- 1 - In order to carry out a control of the rocker arm assembly, it is necessary to disassemble the cylinder head. See «Disassembling the rocker arms» for the correct procedure.
- 2 - Bore a hole in the blocking pin (A), using a 4mm bit, to remove it.
- 3 - Enlever les supports et les culbuteurs du goujon (B).
- 4 - Thoroughly clean the components.

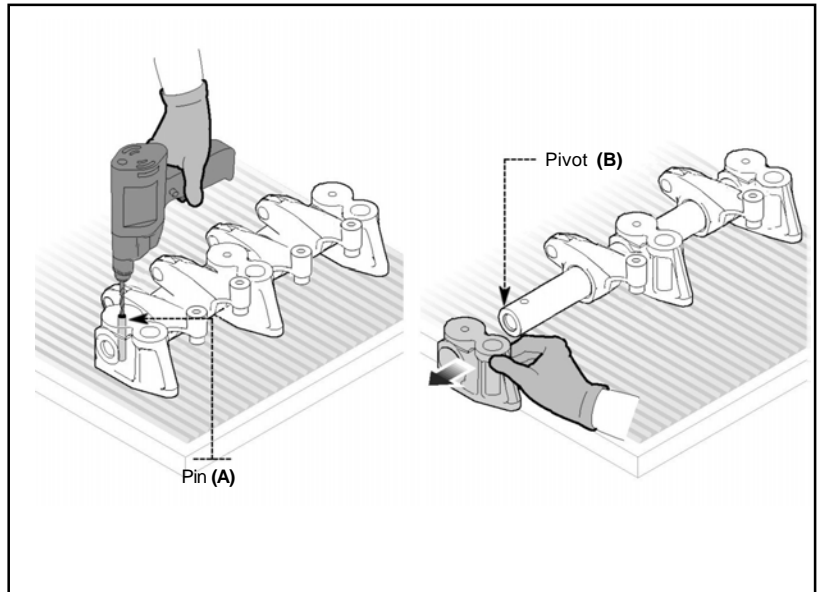

- 5 - Using a micrometer measure the diameters of the pivot pin and the rocker arms (see «Table of pin-rocker arm dimensions »).

Table of pin-rocker arm dimensions

Réf.	Dimensions (mm)	Clearance (mm)	Wear and tear limit (mm)
$\varnothing a$	17,989÷18,000	$\varnothing a - \varnothing b =$	0,090
$\varnothing b$	18,015÷18,030		

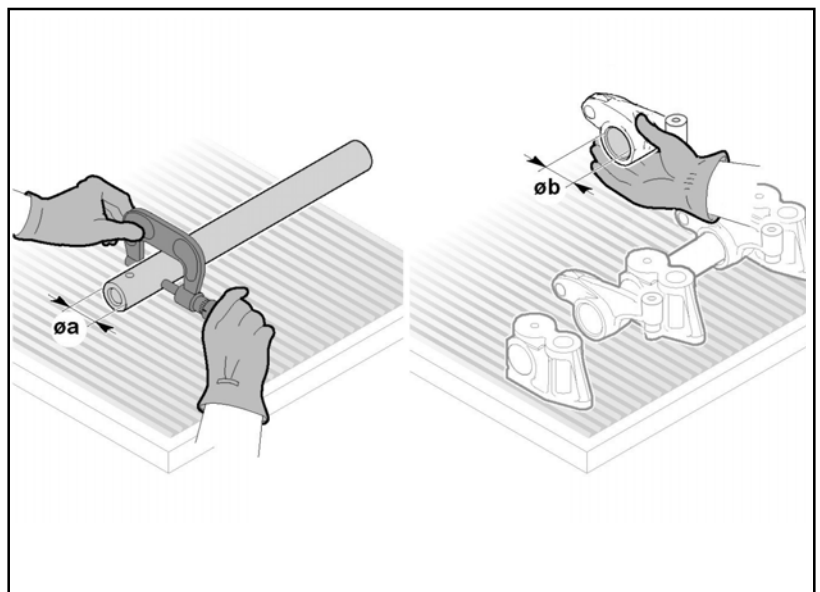

If the diameters do not correspond to the values shown, replace the pin and, if necessary, the rocker arms with original spares.

If the pin can be re-used, remove the plugs and clean the inside carefully, to eliminate residual dirt.

- 6 - Place the new plugs in the pin.
- 7 - Carefully clean and lubricate the supports and rocker arms and remount on the pin.

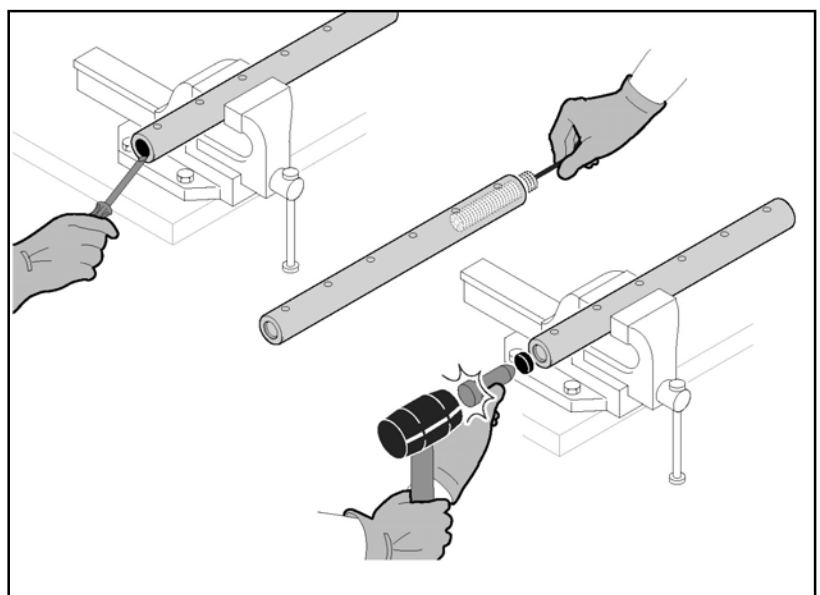

- 8 - Insert a new pin (E) and drive it in 0 - 1mm from the flat part of the support.
- 9 - Reassemble the rocker arm assembly in the cylinder head (see «Assembling the rocker arms»).

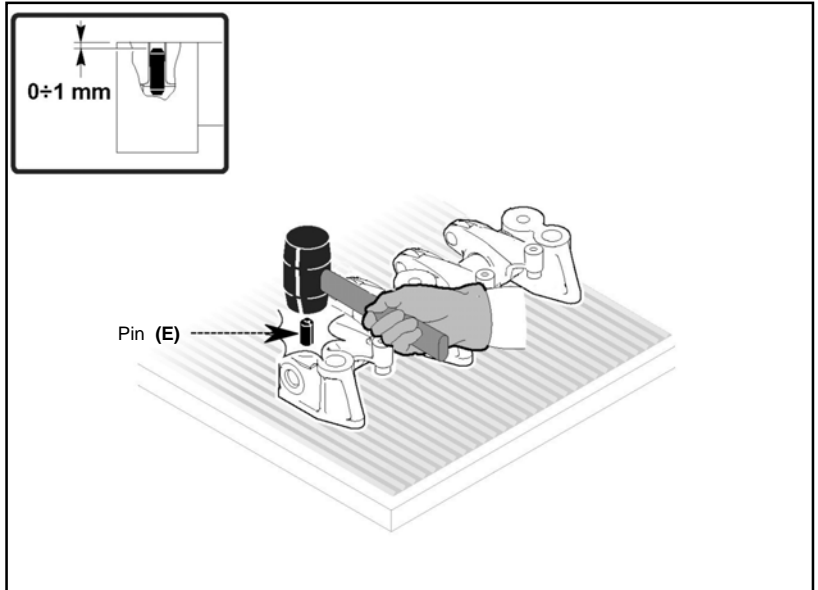

6.3.4 Hydraulic tappets

Hydraulic tappets functioning diagram

Components:

- 1 Hydraulic tappet
- 2 Rocker arm
- 3 Rocker arm pin
- 4 Camshaft
- 5 Valve
- 6 Cylinder head

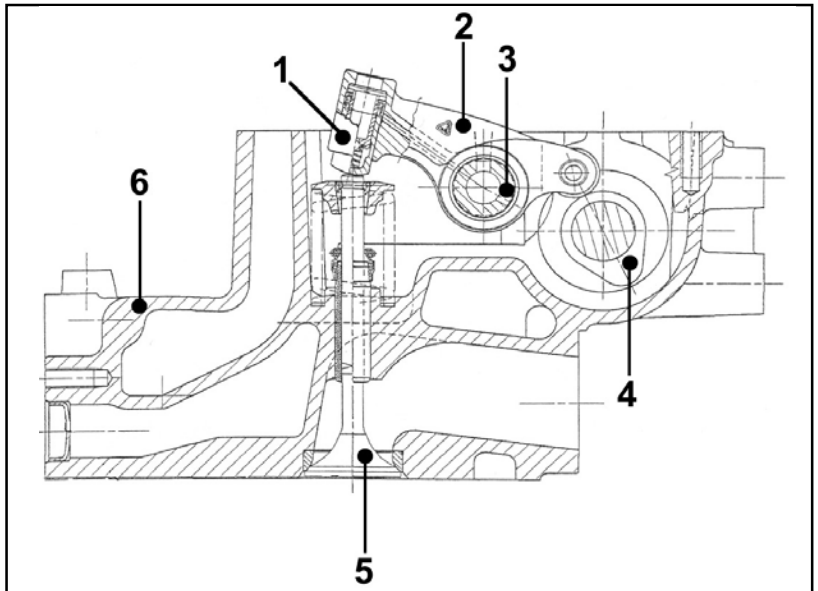

The hydraulic tappet is a device that enables elimination of clearance between timing system components and provides the following advantages:

- Reduces noise levels during operation.
- Reduces wear of the timing system components, thanks to there being no collisions at the opening with consequent breaking of the oil film.
- No maintenance.

Hydraulic tappet components:

- 1 Pad
- 2 Non-return valve
- 3 Plunger
- 4 Tappet body
- 5 Spring
- A Low-pressure chamber
- B High-pressure chamber

The operating principle of the hydraulic tappet is based on the uncompressibility of liquids and on controlled leakage. From the rocker arm and through pad **1** the oil gets into the tappet in chamber **A** on the downward stroke, maintaining a constant flow of oil in the low-pressure chamber. The oil can only enter the high-pressure chamber **B** through the non-return valve **2** and leave via the clearance between the plunger **3** and the tappet body **4** (controlled leakage).

Chamber **B** is filled when the rocker arm is on the bottom of the camshaft and the spring **5** keeps the plunger **3** pressed against the valve stem, thereby eliminating clearance in the system. The lengthening of the spring causes the tappet to «extend», creating a slight depression in chamber **B** and causing the non-return valve **2** to open, thus allowing the oil in chamber **A** to flow into chamber **B** re-establishing the amount of oil needed to maintain zero clearance in the valves.

Difficult operating conditions:

For correct functioning of the hydraulic tappets the pressure chamber of plunger **3** must always be filled with oil.

However, this is not possible in some conditions in that, when the engine is not running, oil leakages may cause partial emptying of the tappets. This situation will cause excessive clearance which will make itself apparent through an unusual ticking sound that is not to be confused with the normal ticking of the injectors.

- 1 - Starting from cold: the engine has not been used for some time and oil may have leaked out of the pressure chamber of the tappets. Moreover, lubricant flows with greater difficulty at low temperatures, and hence several seconds may go by before the tappets are once again supplied with oil.

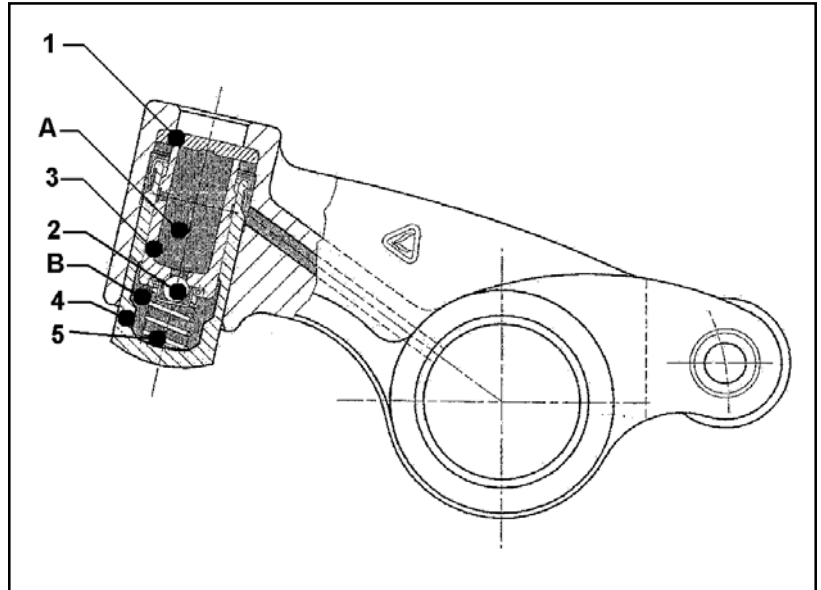

- 2 - Engine very hot: at minimum speed, the oil pressure is low and tiny air bubbles may form inside it (more than 5% of its volume). This causes the lubricant to become compressible and the tappet is squeezed slightly creating clearance and, thus making a noise.
- 3 - Starting and stopping the engine repeatedly (very rare): in this situation the tappets may empty temporarily.

In all three cases the ticking should not last too long. If this is not the case, the problem is definitely due to a manufacturing fault, wear and tear or dirt, which can be drawn in by the oil and get between the non-return valve and its seat inside the plunger, thus compromising the functioning of the tappets. In this case the hydraulic tappets must be replaced.

6.3.5 Checking and replacing the camshaft

In order to carry out a control of the camshaft, it is necessary to disassemble it from the cylinder head. See «Disassembling the camshaft» for the correct procedure.

- 1 - Using a dial indicator, measure the diameters of the seats (X) and, with a micrometer, find the diameters of the camshaft (Y) (see «Table of camshaft dimensions»).

Table of camshaft dimensions

Réf.	Dimensions (mm)	Clearance (mm)	Wear and tear limit (mm)
Ø X	37,035÷37,060	Ø X - Ø Y =	0,170
Ø Y	36,975÷37,000		

If the diameters do not correspond to the values shown, replace the camshaft with an original spare.

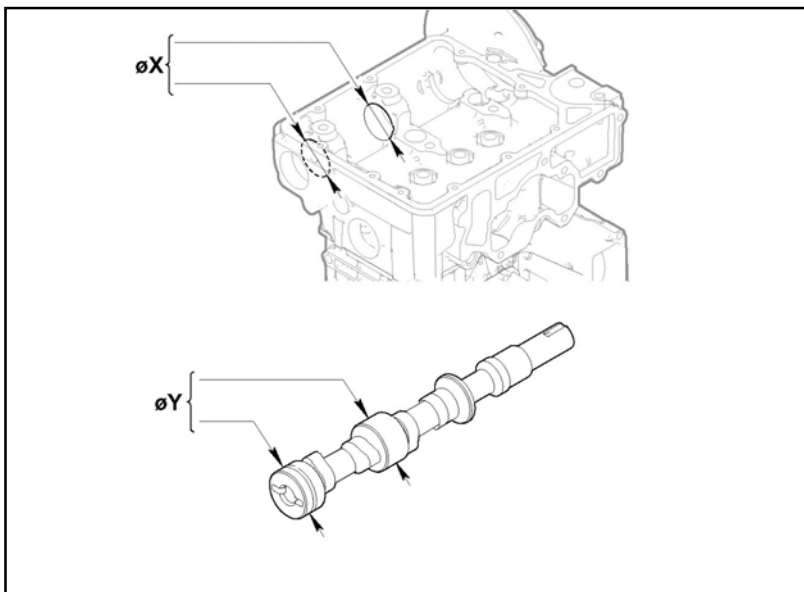

- 2 - Use a micrometer to measure the maximum dimensions of the involutes of the intake and exhaust cams (see «Table of cam dimensions»).

Table of cam dimensions

Réf.	Dimensions (mm)
H	29,578÷29,63

If the dimensions of cam involutes are lower than the values shown by 0.1mm (maximum dimension), replace the camshaft with an original spare.

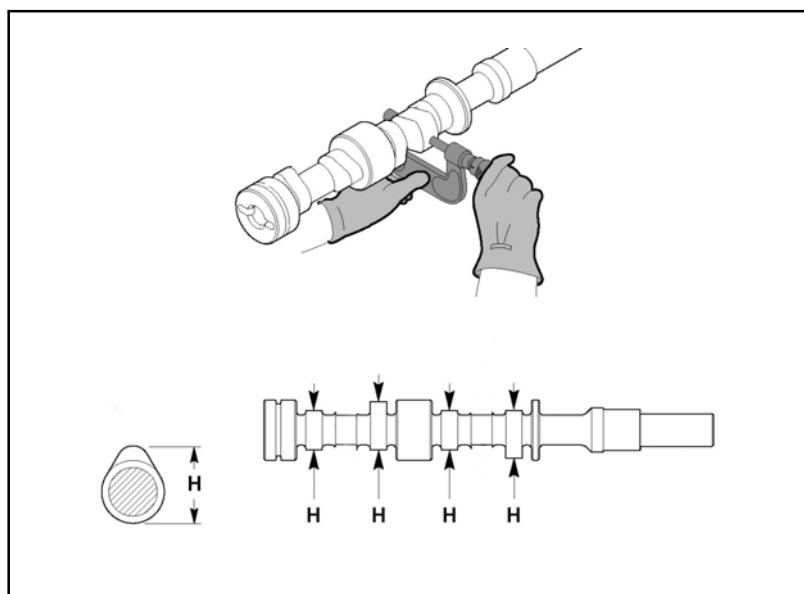

Important

Protect the contact surfaces with lubricant oil, to prevent them from rusting.

- 3 - Mount camshaft (see «Assembling the camshaft»).

6.4 DIAGRAM OF TIMING RATES

Important

Timing rate values are provided below in the timing diagram for information. Please note that, in practice, these values cannot be checked, owing to the presence of the hydraulic tappets.

Timing belt operating angles

- $\alpha = 5^\circ$ before S (top dead centre)
- $\beta = 59^\circ$ after I (bottom dead centre)
- $\gamma = 57^\circ$ before I (bottom dead centre)
- $\delta = 7^\circ$ after S (top dead centre)

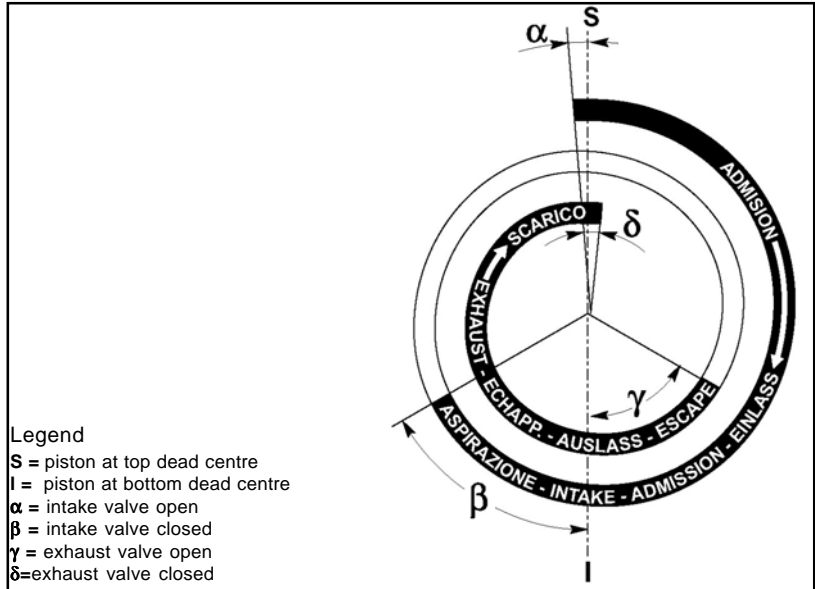

6.5 CHECKING THE SPARK PLUG

The distance between the electrodes must be 0.9-1 mm.

If necessary, clean the electrodes with a bronze bristle brush and blow with compressed air.

If the ceramic insulation is chipped or if the electrodes are worn away, replace the spark plug.

Important

Only replace with the proper spark plugs. Do not use other types of spark plugs with this engine.

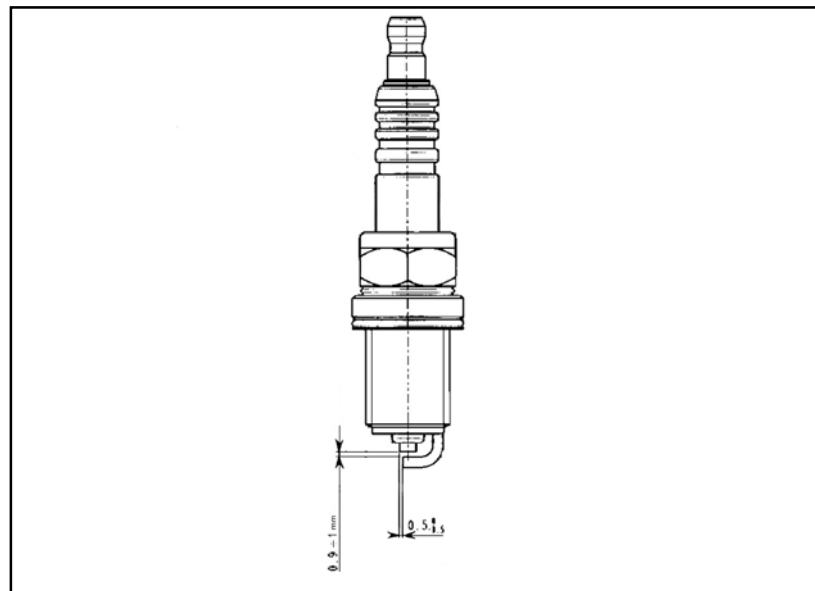

6.6 REPLACING THE FLYWHEEL RING GEAR

In order to replace the ring gear, it is necessary to disassemble the flywheel.
See «Disassembling the flywheel» for the correct procedure.

- 1- Cut the ring gear **(A)** in several places using a chisel and remove it.



Important

Remove any debris and thoroughly clean the ring gear seat holder.

- 2- Heat the new ring gear uniformly and keep it at a temperature of 300°C for 15-20 minutes.



Danger - Attention

Risk of burning: be careful of hot surfaces.

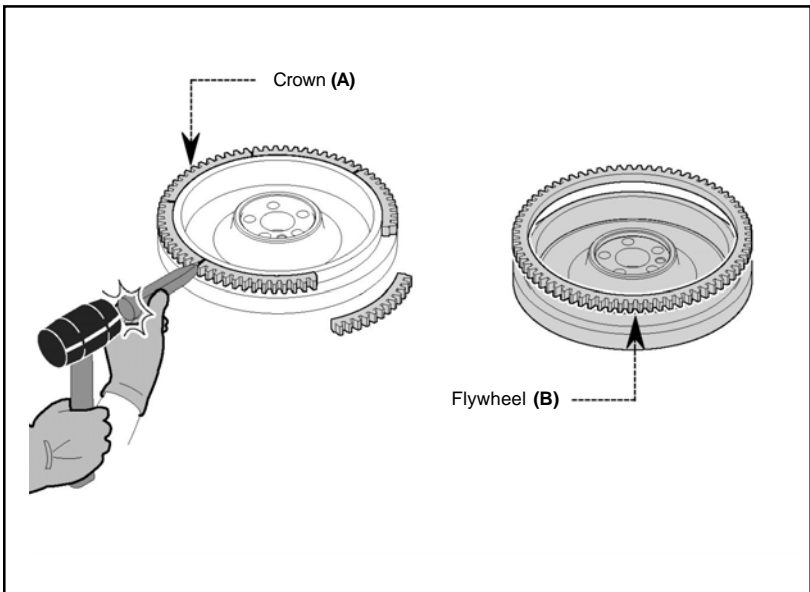

- 3- Insert the ring gear into its seat while still hot and place it carefully on the rim of the flywheel **(B)**.

7.1 RECOMMENDATIONS FOR INSTALLING THE ASSEMBLIES

- Information is given in a logical order in terms of timing and sequence of operations. The methods have been selected, tested and approved by the manufacturer's technical experts.
- This chapter describes procedures for installing assemblies and/or individual components that have been checked, overhauled or replaced with original spare parts.

Important

To locate specific topics, the reader should refer to the index.

- The operator must wash, clean and dry components and assemblies before installing them.
- The operator must make sure that the contact surfaces are intact, lubricate the coupling parts and protect those that are prone to oxidation.

- Before any intervention, the operator should lay out all equipment and tools in such a way as to enable him to carry out operations correctly and safely.
- For safety and convenience, you are advised to place the engine on a special rotating stand for engine overhauls.
- Before proceeding with operations, make sure that appropriate safety conditions are in place, in order to safeguard the operator and any persons involved.
- In order to fix assemblies and/or components securely, the operator must tighten the fastening parts in a criss-cross or alternating pattern.
- Assemblies and/or components with a specific tightening torque must initially be fastened at a level lower than the assigned value, and then subsequently tightened to the final torque.

7.2 INSTALLING VALVES

7.2.1 Montage soupapes

Important

- Make sure that the cylinder head is perfectly clean and dry.
- Check that all components are intact and, if necessary, replace them with original spares.

- 1- Lubricate the valve stem sealing ring (A), insert it into tool «717-1460-047», and mount it right into the seat of the valve guide.
- 2- Lubricate the valve stem (B).
- 3- Slip the valve into its seat.

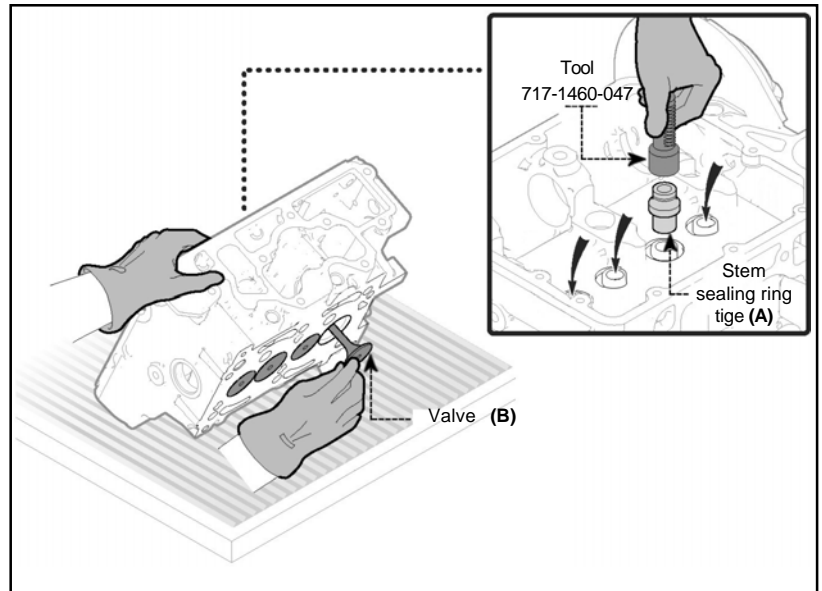

- 4 - Mount the collar (C), the spring (D), the cup (E) and the half collets (F).
- 5 - Press down hard on the cup (E), using the special tool to insert the half collets (F) into the valve stem groove.
- 6 - Release the tool and check that the half collets are positioned correctly.
- 7 - Repeat the same operation on the other valves.

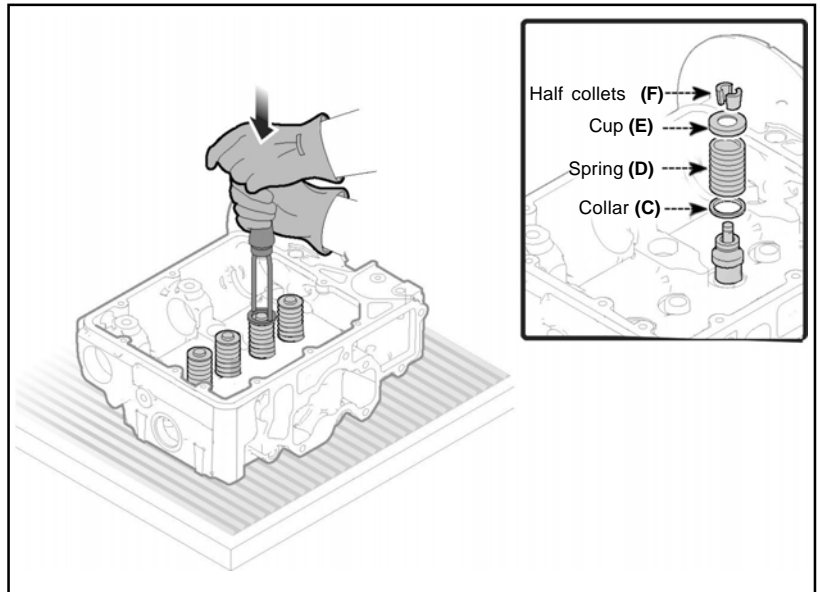

7.3 PREASSEMBLY OF SEALING RINGS - PISTONS

- 1 - Thoroughly clean the pistons and lubricate the coupling areas.
- 2 - Put the sealing rings on the piston in the order shown in the figure.

i Important

- Place the sealing rings with the markings facing up towards the upper part of the piston (crown).
- Keep the pistons together with their own connecting rods and wrist pins.

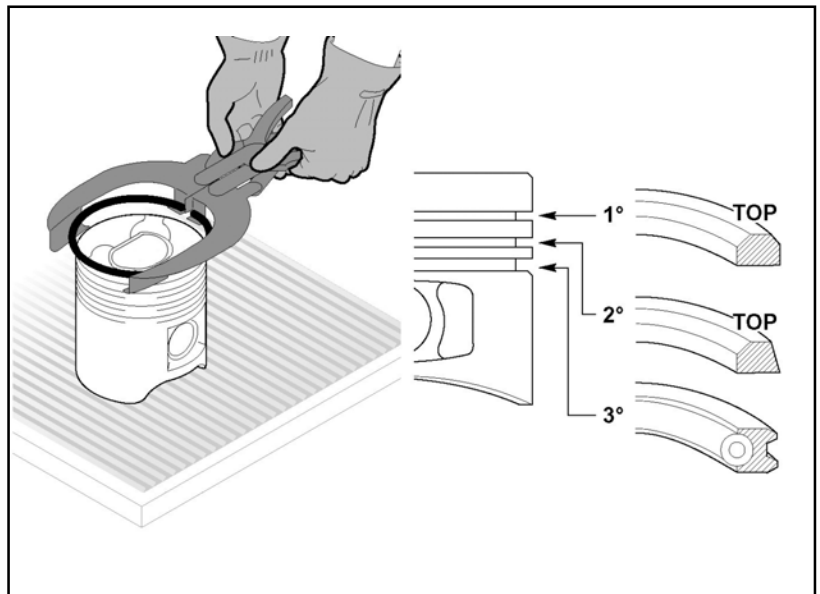

7.4 PRE-ASSEMBLY CONNECTING RODS – PISTONS

Important

Before pre-assembly, check that the weight difference between the two connecting rod-piston-wrist pin assemblies does not exceed 6g to prevent weight imbalances.

- 1 - Lubricate the wrist pin (A) and the seat of the small end of the connecting rod (B).
- 2 - Place the lock ring (C) on the piston complete with sealing rings (D).

Important

Insert the lock rings with the tips pointing towards the base of the piston with a tolerance of 15°.

- 3 - Make sure the lock rings are positioned correctly in their seats.
- 4 - Lubricate the coupling parts and those that are prone to oxidation.

Important

- Make sure the lock rings are positioned correctly in their seats.
- Lubricate the coupling parts and those that are prone to oxidation.

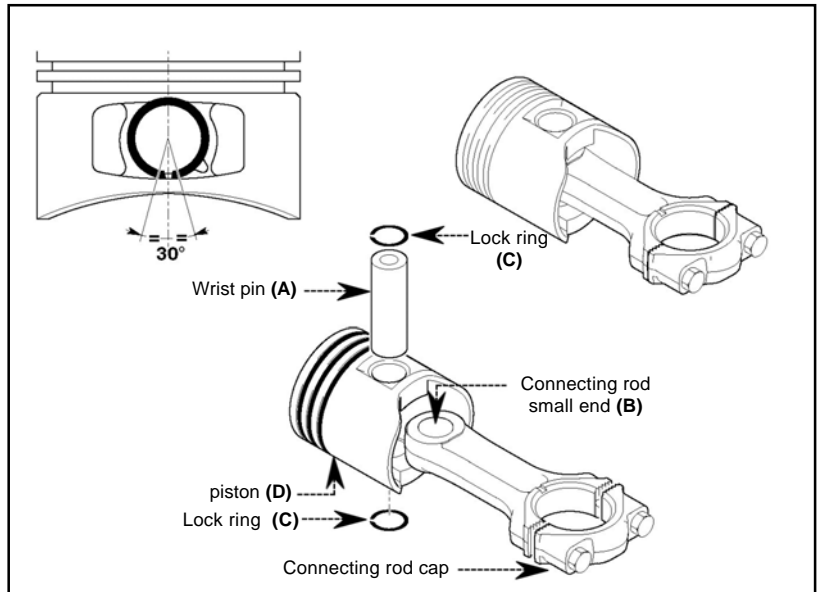

7.5I INSTALLATION OF CRANK GEAR AND CRANKCASE

7.5.1 Installing piston/connecting rod - engine block

Important

Make sure that the engine block and crankcase are perfectly clean and dry.

- 1 - Assemble the pipe (A) with the oil suction filter.
- 2 - Mount the new O-rings (A1).
- 3 - Apply a film of Loctite Q3-7091 adhesive on the oil passage surfaces (A2) as in the figure.
- 4 - Carefully clean and lubricate the cylinders and the connecting rod-piston-snap ring assembly.
- 5 - Rotate the sealing rings so that the cuts have a displacement of about 120° between them.

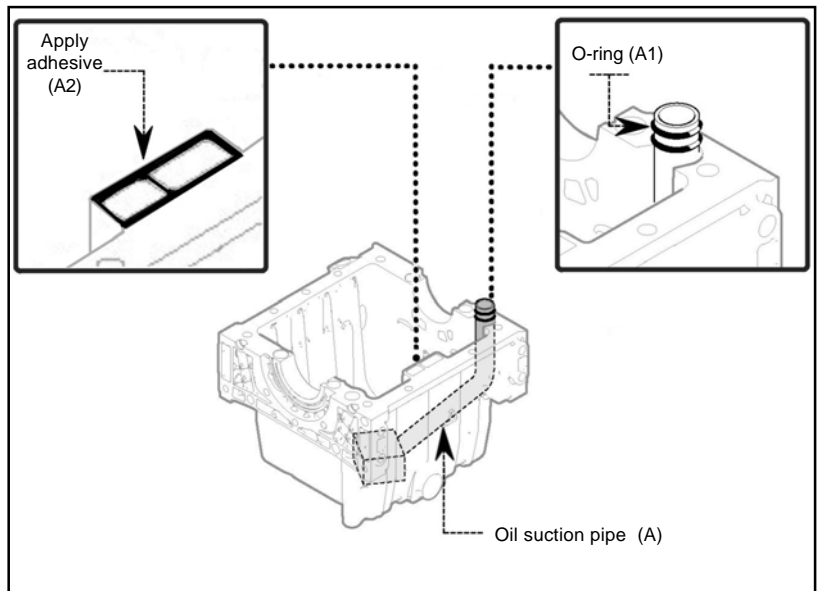

Important

In order not to damage the sealing rings and the contact areas while inserting the piston into the cylinder, use the special containment device.

- 5 - Mount the connecting rod-piston assembly (B) onto the engine block and position the connecting rod big ends along the axis of the crankshaft.

Important

The intake valve impression on the piston crown (larger than on the exhaust valve) must face the timing belt side.

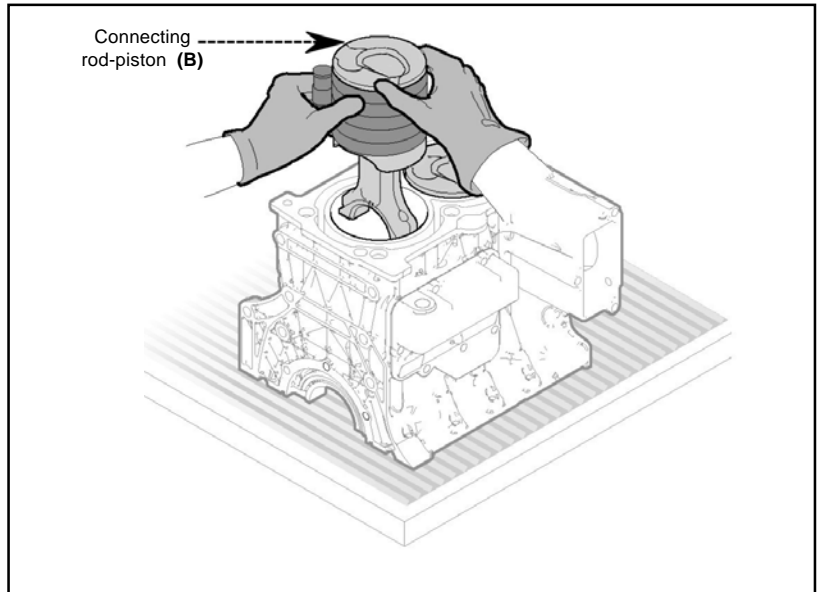

7.5.2 Assembling the crankshaft

Caution – Warning

The crankshaft and connecting rod half bearings are made out of special lead-free material, and hence must strictly be replaced with new ones every time they are removed in order to prevent seizure.

- 1 - Mount the half-bearings (C) and the shoulder half-rings (E) (flywheel side only).

Important

The shoulder half-rings must be placed with the lubrication grooves facing outwards of the support.

- 2 - Lubricate the crankshaft half bearings (C), the connecting rod half bearings on the big ends (D) and on the connecting rod caps (F).
- 3 - Carefully clean and lubricate the crankshaft main journals and crank pins.
- 4 - Install the crankshaft (G).
- 5 - Install the connecting rod caps (F) complete with half bearings and put in the screws.
- 6 - Tighten the connecting rod cap screws to a temporary torque of 25Nm.
- 7 - Tighten the connecting rod cap screws to a final torque of 50Nm.
- 8 - Assemble the crankcase (see «Assembling the crankcase»).
- 9 - Measure the axial clearance of the crankshaft (see «Measuring crankshaft axial clearance»).

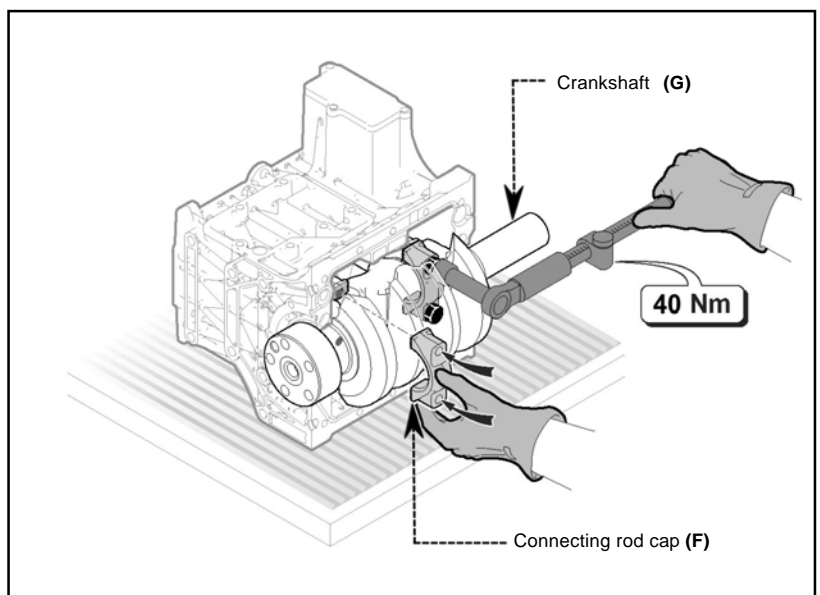
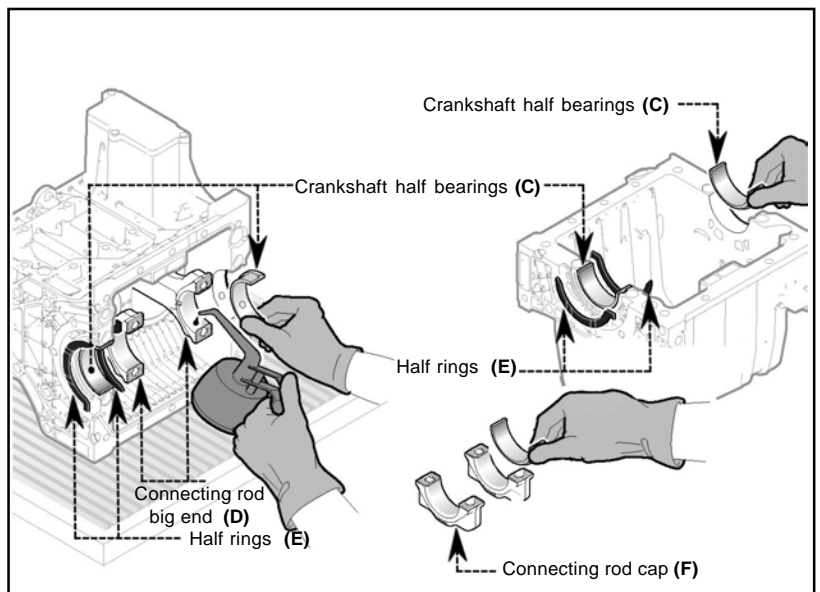

7.5.3 Assembling the crankcase

Important

- Make sure that the contact surfaces and related pins are perfectly intact and clean.
- Make sure there are no foreign bodies or residual material in the engine block and crankcase.

- 1 - Mount the new gaskets (**H1-H2**) for the engine block contact surface with the crankcase.
- 2 - Replace the crankcase (**H**) and put in the screws (**L-M**).
- 3 - Tighten the screws (**L**) temporarily in a crisscross pattern.
- 4 - Tighten the screws (**M**) temporarily in an alternating pattern.
- 5 - Tighten the screws (**L**) in a crisscross pattern to a final torque of 50Nm.
- 6 - Tighten the screws (**M**) in an alternating pattern to a final torque of 10Nm.

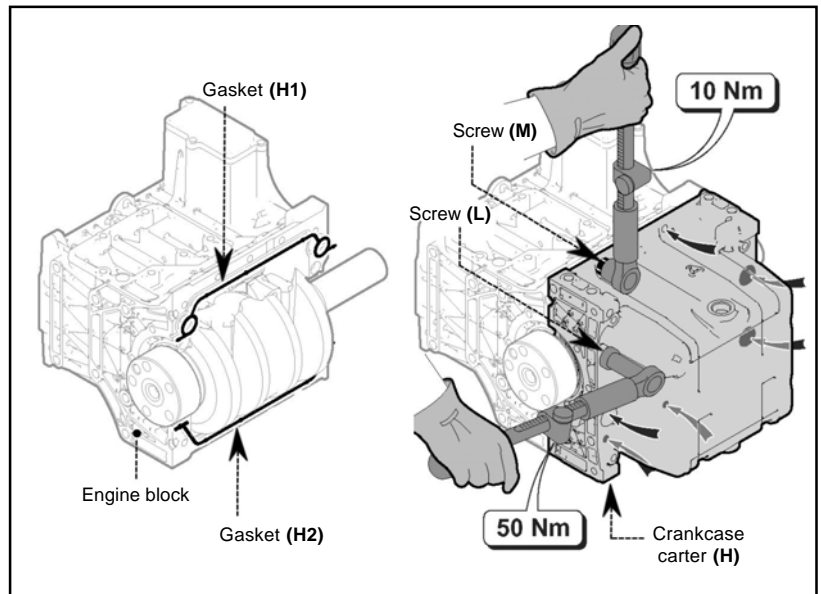

7.5.4 Checking crankshaft axial clearance

To measure the axial clearance of the crankshaft, it is necessary to assemble the shaft complete with crankcase.

See «Assembling the crankcase» for the correct procedure.

- 1 - Using a dial indicator, measure the axial shift of the crankshaft. Axial shift must be between 0.13 and 0.313mm. If axial shift is above these values, it is necessary to insert uprated shoulder half-rings and once again disassemble the crankcase (see «Dimensional check and overhaul of crankshaft»).

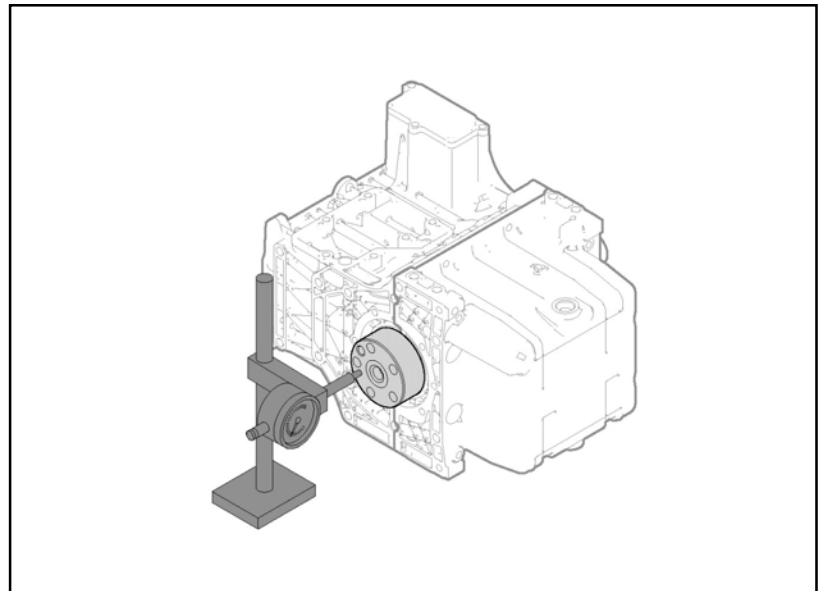

7.5.5 Assembling the crankshaft flange (flywheel side)

- 1 - Clean the flange and the sealing ring seat **(N)**.
- 2 - Using the special pad, insert a new sealing ring **(N)** into the flange **(Q)**.

Important
 Given the particular function played by this sealing ring, it is important to use only original spares.

- 3 - Check that the contact surfaces are perfectly clean and intact.
- 4 - Slip on a new gasket **(P)**.
- 5 - Install the flange **(Q)** and put in the screws **(R)**.

Importante
 Be careful not to damage the sealing rings during this operation.

- 6 - Tighten the screws **(R)** in a crisscross pattern to a final torque of 12Nm.

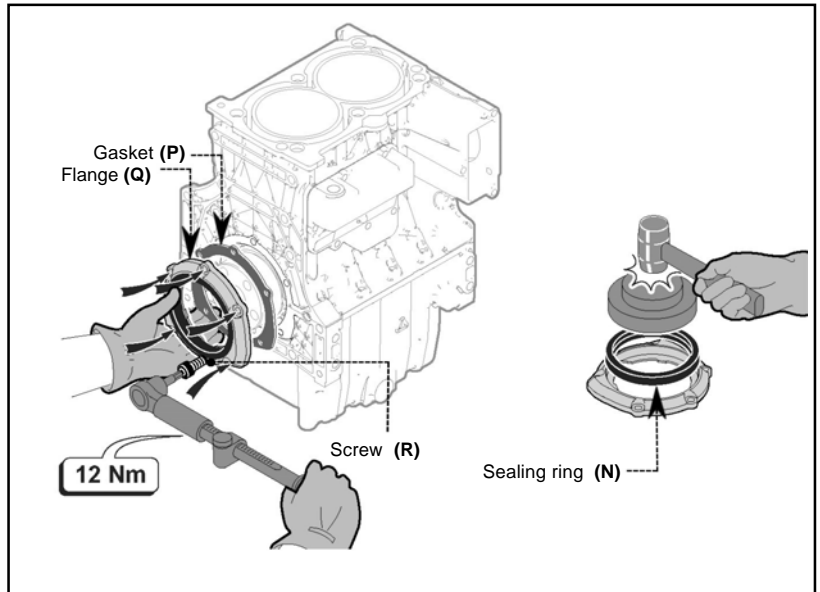

7.5.6 Installing the pump scroll

- 1 - Clean the flange and the pump scroll seat.
- 2 - Slip on a new gasket **(A)**.
- 3 - Install the pump scroll and put in the screws.

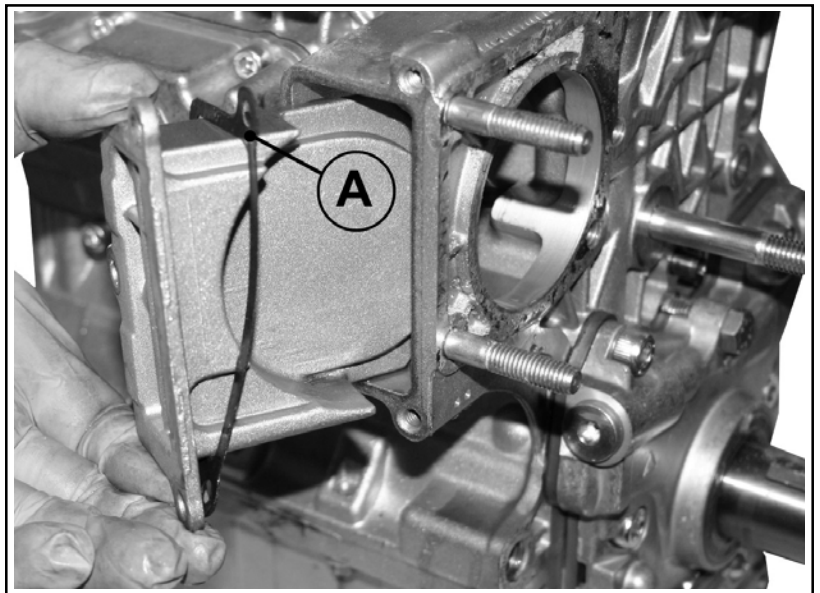

4 - Tighten the screws to 6 Nm.

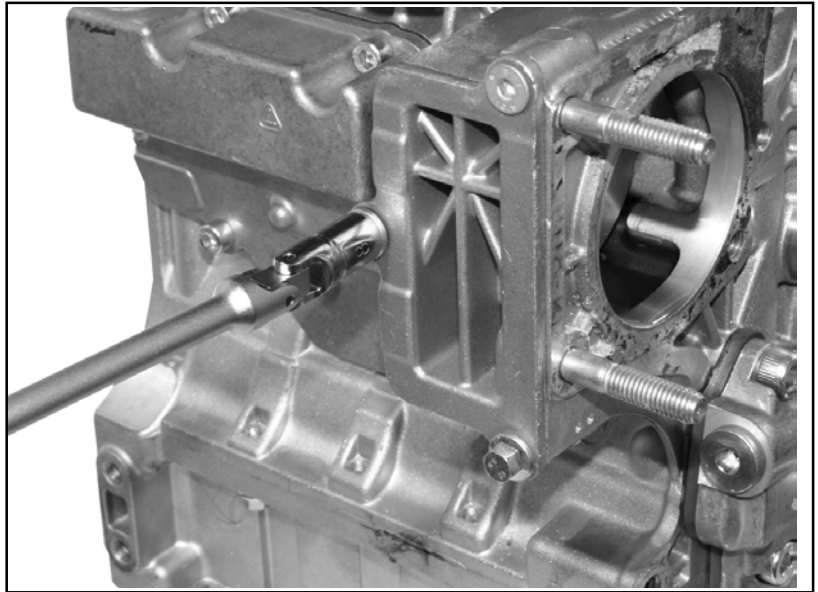

7.5.7 Installing the coolant circulation pump

- 1 - Clean the flange and the water pump seat.
- 2 - Slip on a new gasket.
- 3 - Install the pump and tighten the screws and nuts to 20 Nm.



Important

Following a failure, the coolant pump cannot be repaired and must be replaced with an original spare.

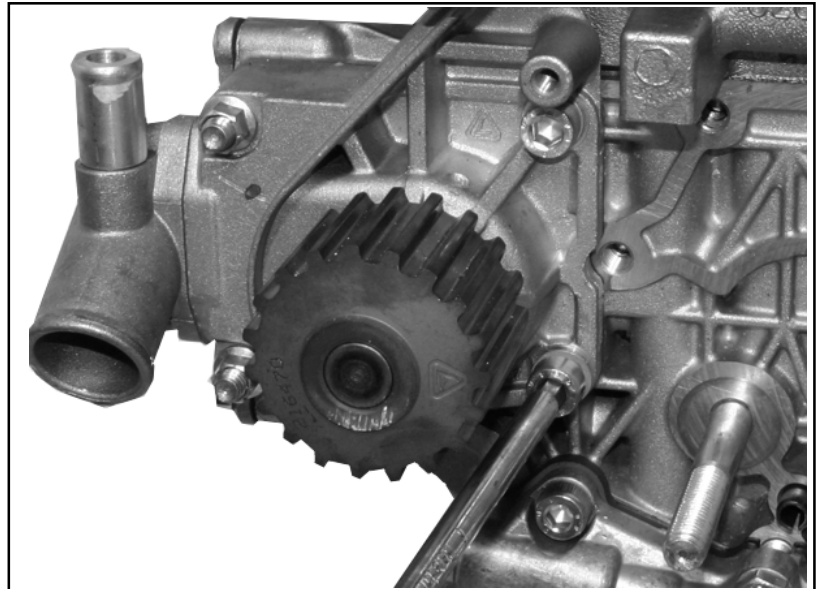

7.5.8 Assembling the oil pump

Before installing the oil pump, make sure there are no malfunctions (see «Checking and overhauling the oil pump»).



Important

Check that the contact surfaces are perfectly clean and intact.

- 1 - Slip on a new gasket (A).
- 2 - Insert the oil pump activation key into the crankshaft.
- 3 - Bring the pistons to the top dead centre with the oil pump activation key in line with break in the flange, in order to be able to assemble the pump.
- 4 - Install the pump (B) and put in the screws (C).



Important

Be careful not to damage the sealing rings during this operation.

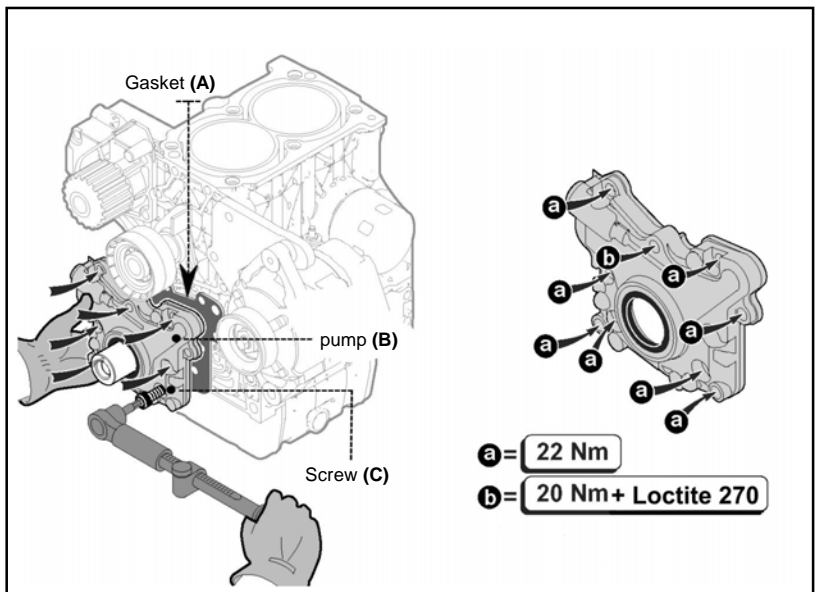

- 5 - Tighten the screws in a crisscross pattern, and tighten each of them to their respective final torques (see figure).

- 6 - Insert the key (D) into the crankshaft.
- 7 - Install the alternator support (E) and tighten the screws to a torque of 22Nm.

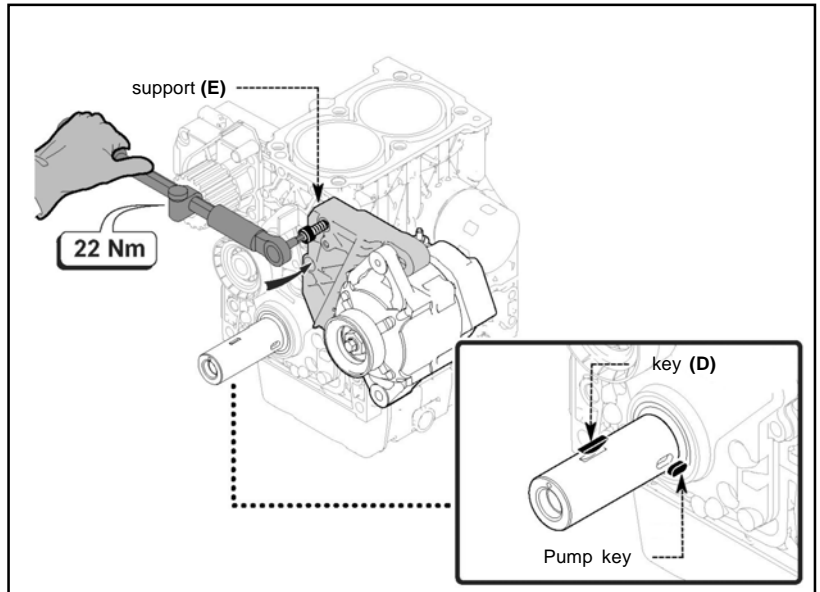

7.5.9 Assembling the flywheel

- 1 - Install the starter motor support (F) and tighten the screws to a torque of 25Nm.

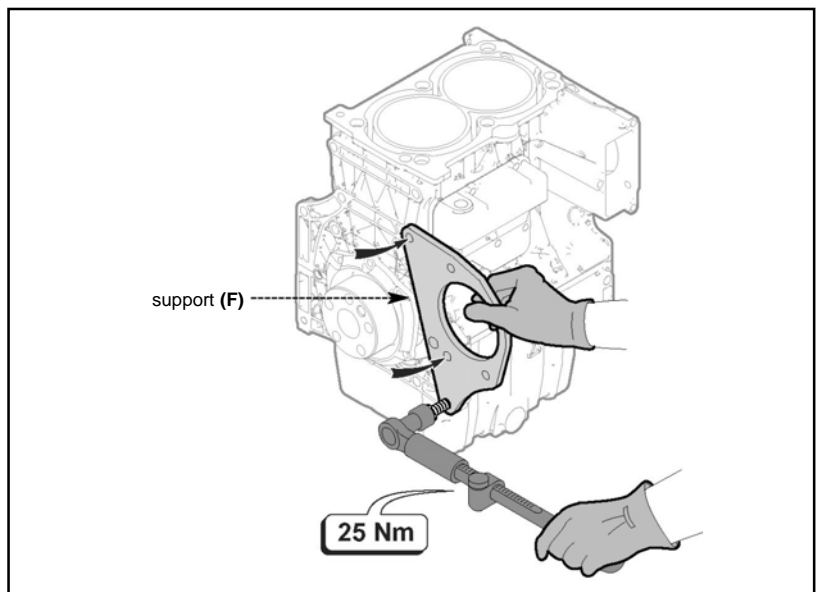

- 2 - Install the flywheel (G) and put in the screws (H).
- 3 - Tighten the screws temporarily in crisscross order.
- 4 - Tighten the screws in crisscross order to a final torque of 80Nm.



Important

Turn the flywheel manually to check the movement of the mechanical parts.

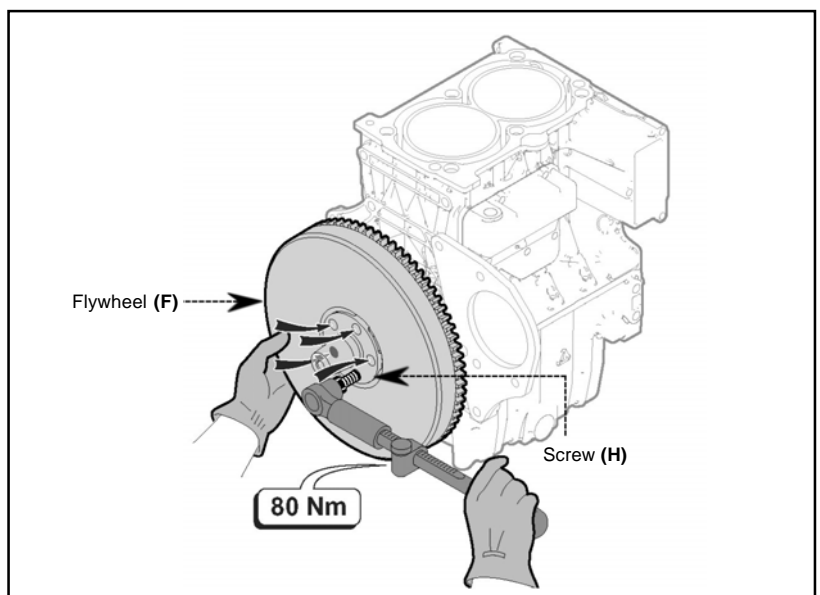

7.5.10 Determining clearance volume

- 1 - Position the pistons at the top dead centre.
- 2 - Measure the distance from the piston crown to the crankcase surface in four diametrically opposite points.
- 3 - Repeat the operation on all pistons.
The maximum value determines the measurement **(A)** which must be between 0.95 and 1.2mm.

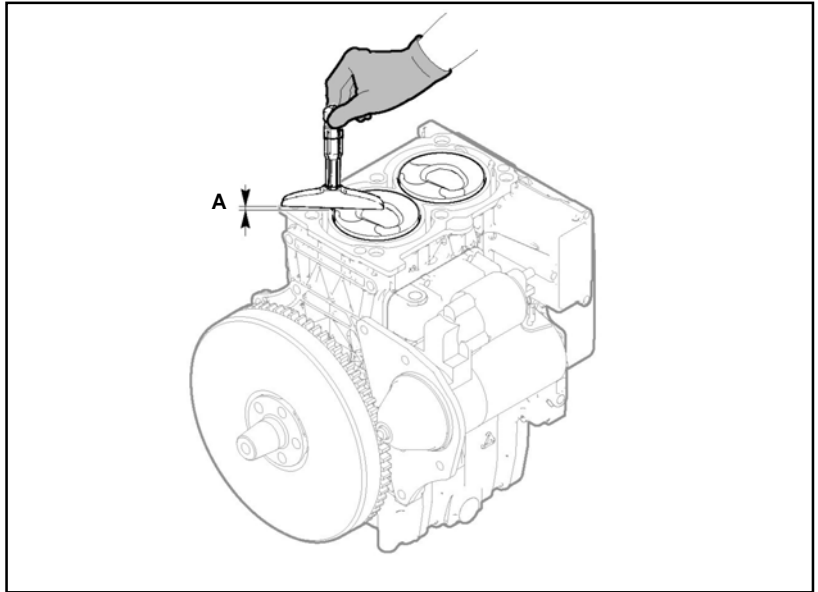

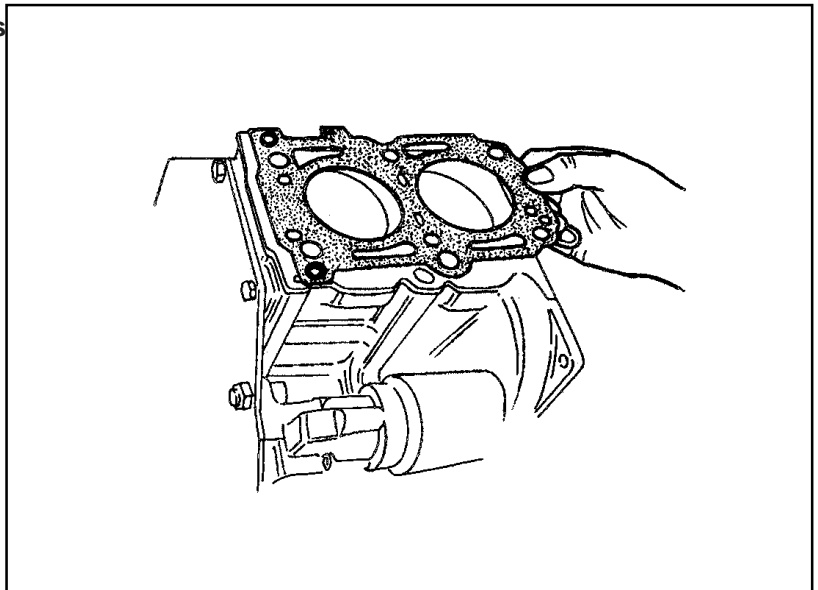

Table of gasket and clearance volume values

A (mm)	Number holes of	Clearance volume(mm)
0,95÷1,20	2 	0,45÷0,70

Important

The two-hole head gasket is rigorously to be installed on engine LGW 523 MPI.



7.6 INSTALLATION OF CYLINDER HEAD AND COMPONENTS

7.6.1 Assembling the cylinder head

Important

- Make sure there are no foreign bodies or residual material in the cylinder head cavity.
 - Check that the contact surfaces are perfectly clean and intact.
- 1- Install a new gasket whose thickness has been determined previously (see «Determining clearance volume»).

Important

Make sure that the length of screws (1), (2), (3), (4) and (5) does not exceed 92mm, whereas screw (6) should be no longer than 66.5mm, otherwise replace them.

- 2- Lubricate the screws copiously.
- 3- Mount the cylinder head and put in the screws.
- 4- Tighten the screws in sequence (see diagram) to a torque of 40Nm.

Important

Use a torque wrench with an angle torque tool to tighten the screws.

- 5- Tighten the screws further clockwise, rotating 90° according to the sequence shown in the figure.
- 6- Tighten the screws to their final torque, rotating 90° more.

Important

If the screws belong to 10.9 class, the tightening torque is 60Nm and it is not necessary to tighten them further

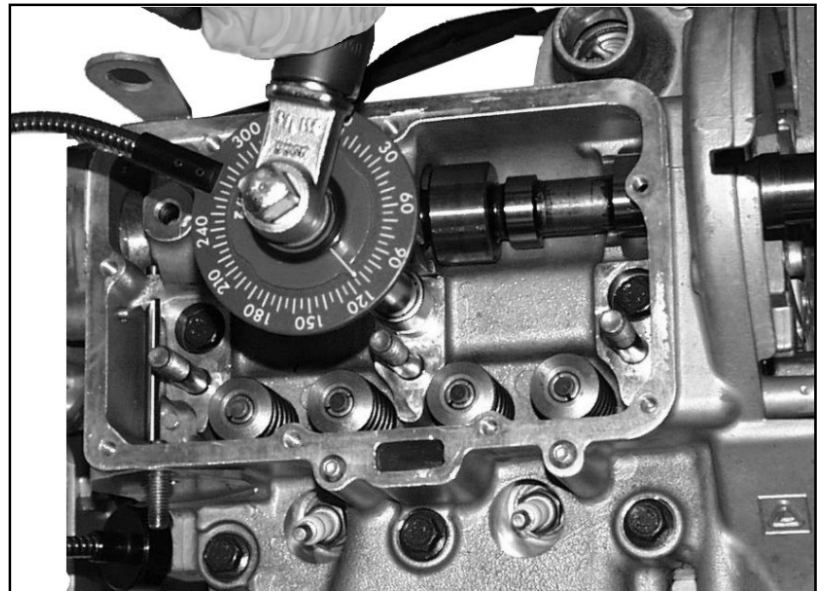
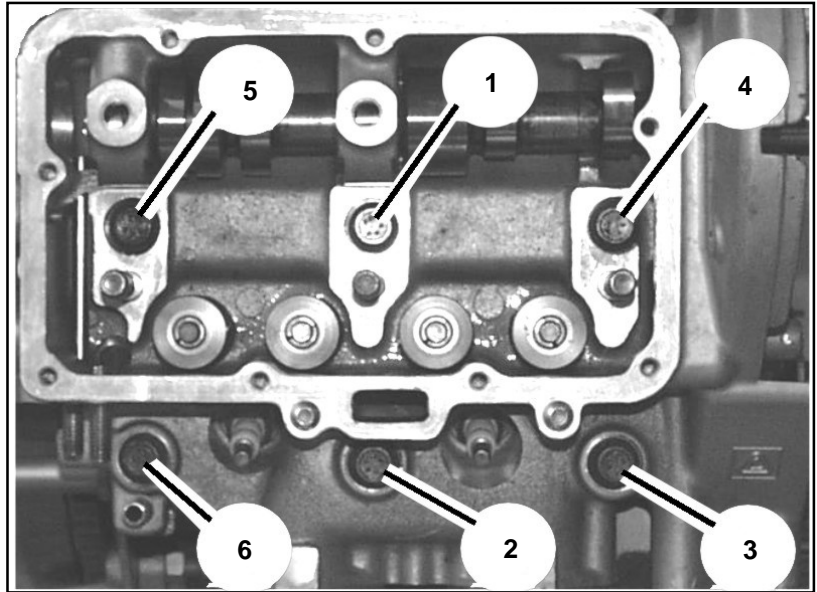

7.6.2 Assembling the camshaft

Important

Make sure that the camshaft and its housing are perfectly intact and clean.

- 1- Lubricate the camshaft (A) and its housing.
- 2- Insert the camshaft into its housing.
- 3- Mount a new O-ring onto the cover (B).
- 4- Mount the cover (B) and tighten the screws to a torque of 10Nm.

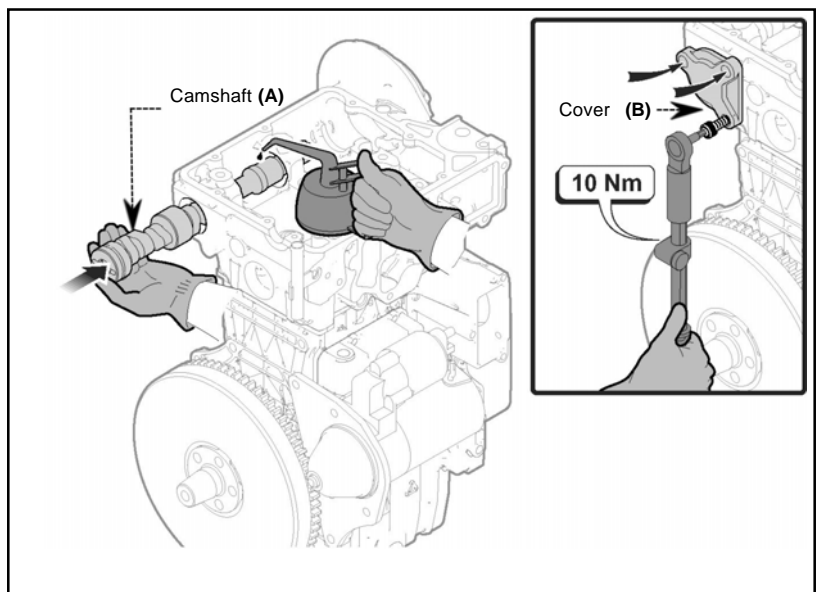

7.6.3 Installing the camshaft support and timing belt pulley

Components:

- 1 Timing pulley
- 2 Camshaft support flange
- 3 Oil seal
- 4 Bearing seal plate
- 5 Spacer
- 6 Bearing

- 1 - Install the spacer (5) and the camshaft support (2) complete with bearing (6), oil seal ring (3) and O-ring.
- 2 - Tighten the screws on the camshaft support to a torque of 10 Nm.

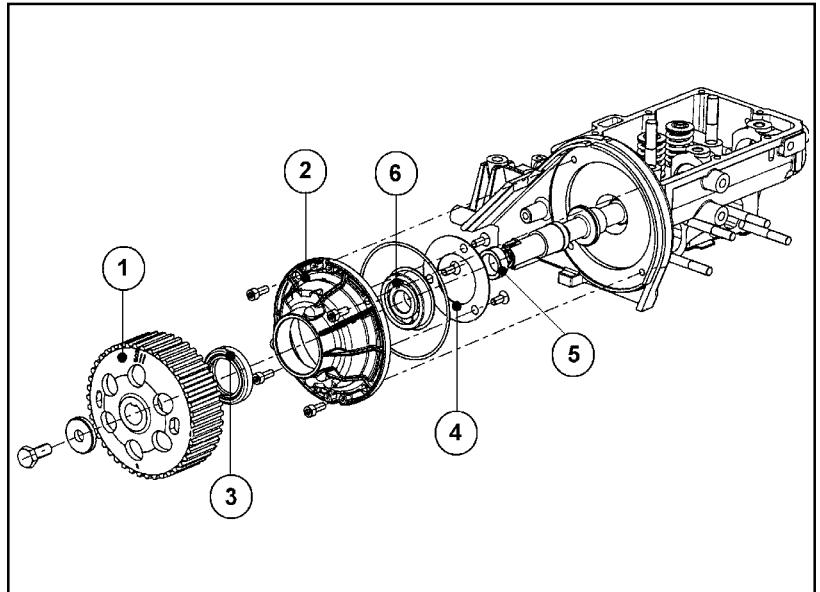

7.6.4 Installing the rocker arm assembly



Important

Position the crankshaft at between 75° and 90° after the TDC timing reference mark, in that the presence of the hydraulic tappets may cause a collision between the valves and the pistons, when these are at top dead centre.

Lay the complete rocker arm support on the cylinder head and screw in the support nuts to a torque of 40 Nm, following the sequence in the figure.

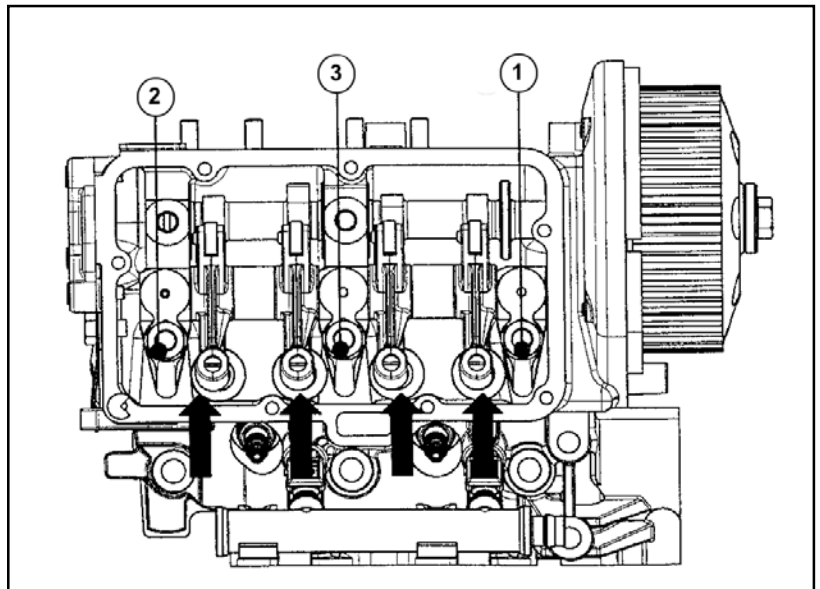

Caution - Warning

Do not run the engine for ~ 30 minutes with an ambient temperature of 20°C to prevent the piston from colliding with the valves.



Important

Before starting the engine, allow it to make a few complete rotations to make sure that the valves do not collide with the pistons.

7.6.5 Installing the rocker arm cover

The rocker arm cover gasket ensures sealing of the camshaft lubrication circuit with the rocker arm pin, hence it is important to replace it every time that it is removed, and to take particular care when reinstalling it.

Any damage or breakage of the gasket may cause a drop in pressure in the lubrication circuit.

On reassembly of the cover, tighten the screws to 9Nm.

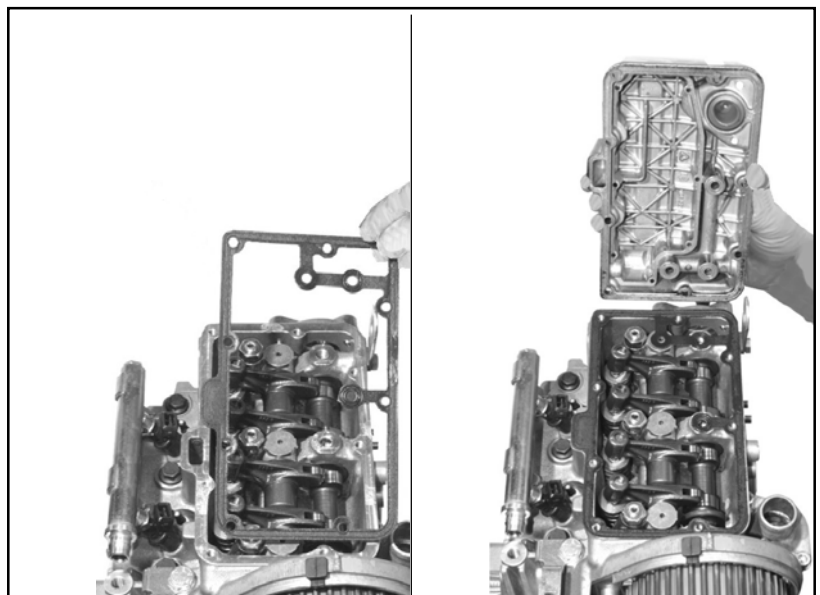

7.6.6 Installing the spark plug

Assemble the spark plugs by tightening manually up to the rim.
 The final torque reading must be 30 Nm or a wrench angle of 90°.
 If the ceramic insulation is chipped or if the electrodes are worn away, replace the spark plug (the new spark plug must be identical to the old one).

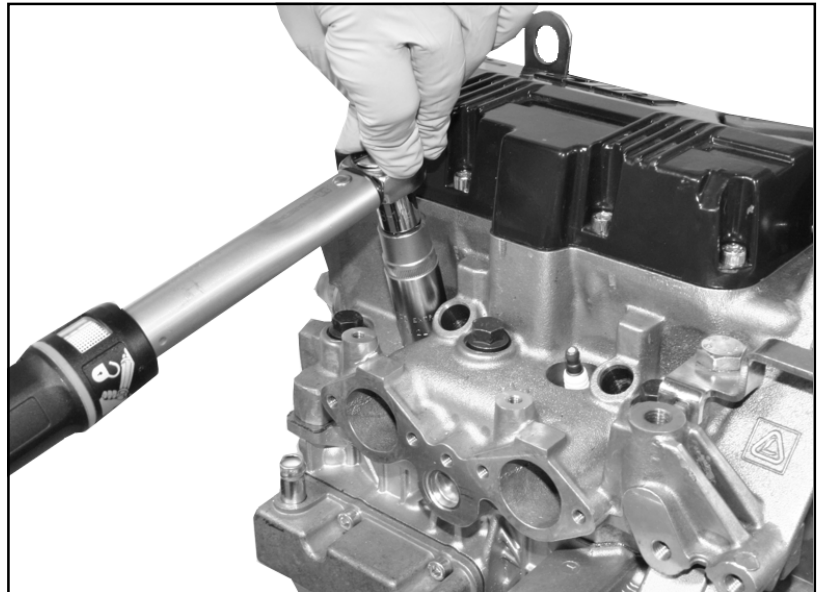

7.6.7 Installing the injectors

Injectors cannot be repaired. In the event of malfunctioning or failure, replace them.



Important

Given the particular function played by this sealing ring, it is important to use only original spares.



Important

Before installation, thoroughly oil the injector O-rings.

- 1 - Insert the injectors into their seat on the fuel supply pipe, being careful not to damage the O-rings.
- 2 - Insert the check spring to block the injector on the fuel supply pipe. Repeat this operation on the other injector.

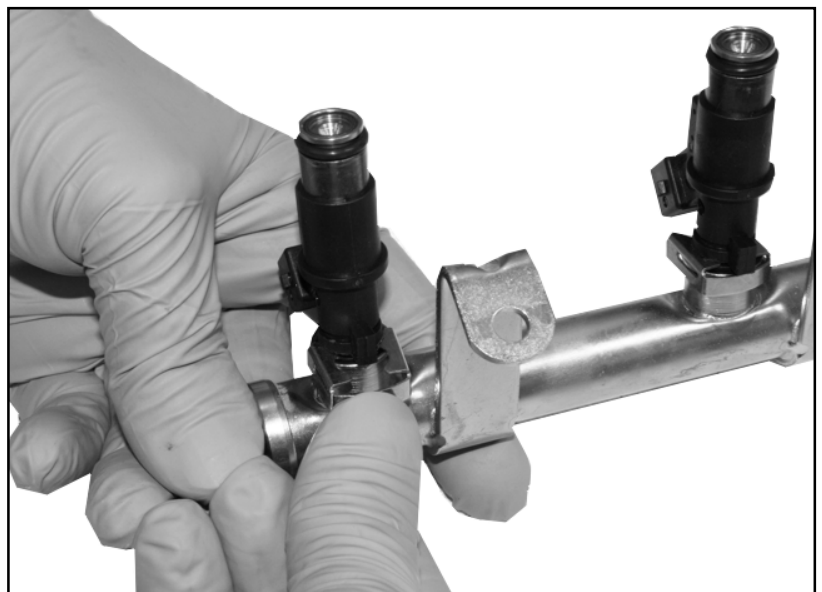
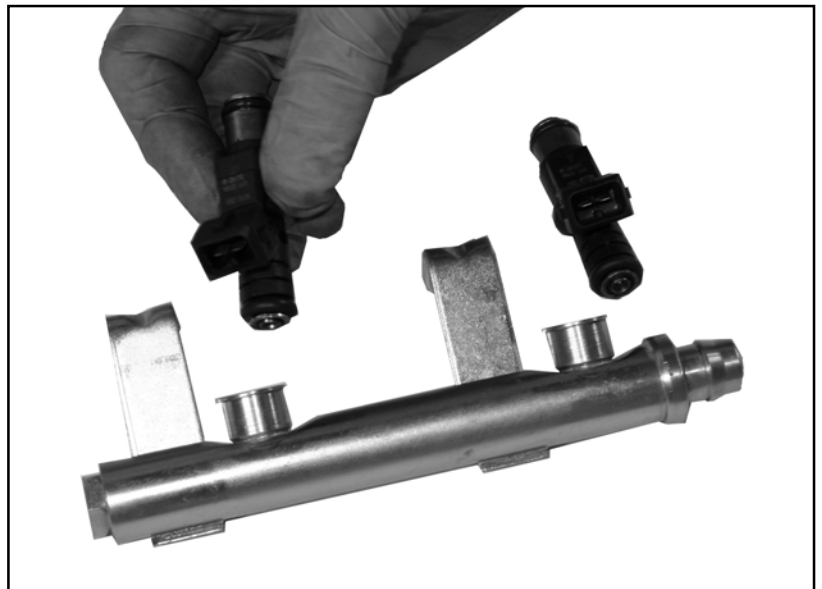

- 3- Insert the injector/fuel supply pipe assembly into the cylinder head, positioning the injectors so that the electrical connector sockets are facing the rocker arm cap (see figure). Be careful not to damage the oil seal rings.



Important

Before installation, thoroughly oil the injector O-rings.

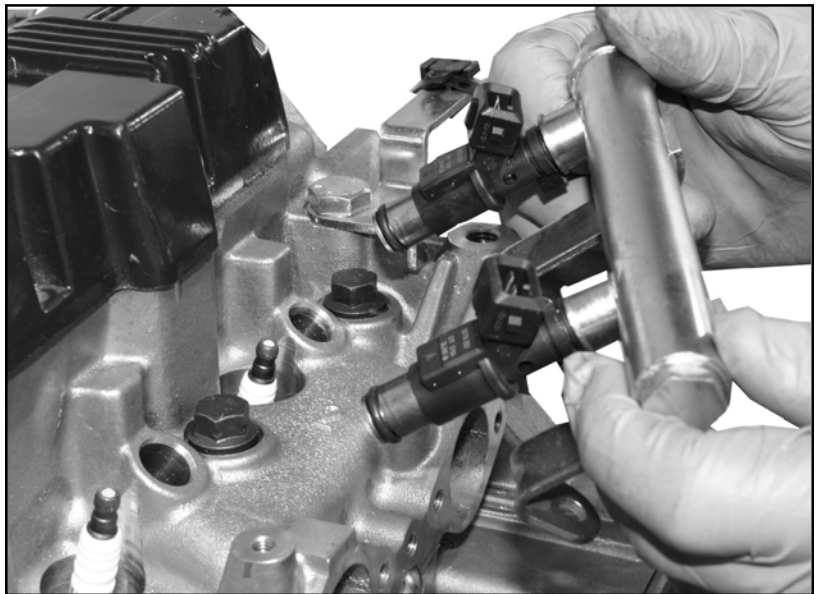

- 4- Insert the screws into the fixing brackets of the fuel supply pipe and tighten to 10 Nm.



7.6.8 Installing the thermostatic valve body

- 1- Carefully clean the seat and flange of the thermostatic valve support.
- 2- Slip on a new gasket.
- 3- Put in the screws and tighten to 20 Nm.

The thermostatic valve body holds the coolant temperature sensors **(A)** and the coolant thermometer sensor **(B)**.

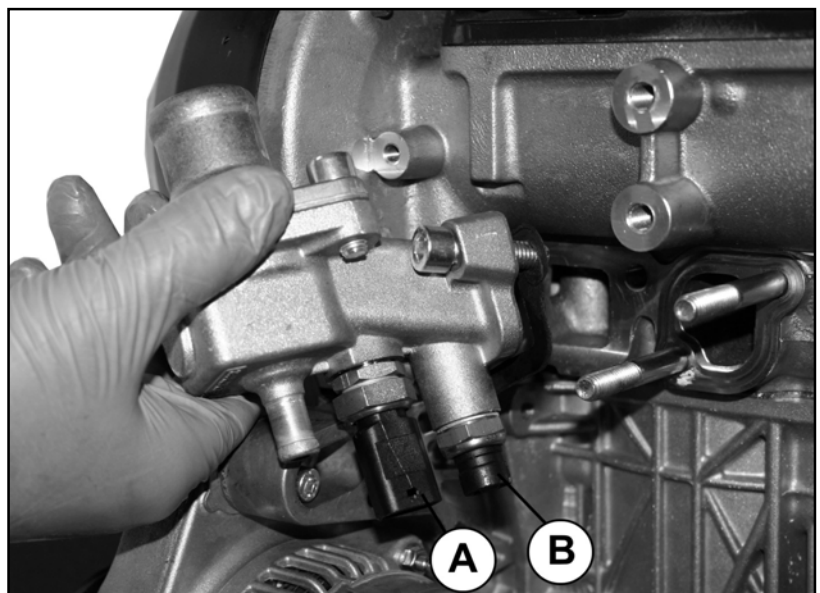

Important

Replacement may be carried out with the engine installed on the machine.

- 1 - Switch off the engine and leave to cool.
- 2 - Remove the cover.
- 3 - Remove the valve and make sure it is working properly.

Important

The valve must be heated in order to check whether it is functioning correctly.

- Dip the thermostatic valve in a metal container of water.
- Use a thermometer with a full scale of 150°C to monitor the temperature of the water in the container.
- Heat the water and, using the thermometer, make sure that the temperature at which the valve begins to open is between 78 and 82°C.
- If the thermostatic valve opens at a different temperature, it must be replaced.
- Maintaining the conditions described above, heat the water to 94°C and check whether or not the valve is completely open at this temperature, i.e. that it has lifted to 7mm.

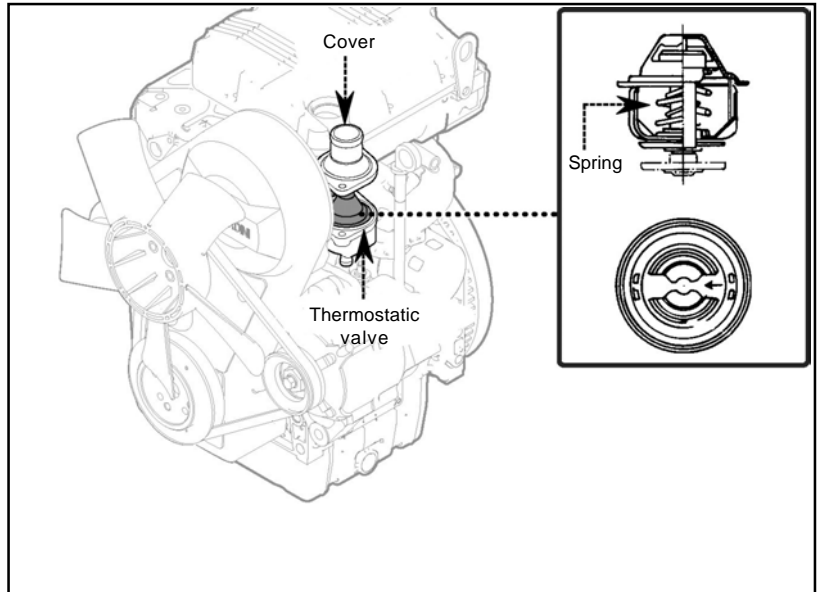

- Check whether the valve is completely shut once it has cooled down.

If the length does not correspond to the value shown, replace the valve spring with an original spare.

- 4 - Mount the cover and fasten the screws.

7.7 INSTALLATION OF THE TIMING BELT DRIVE

7.7.1 Assembling the phase sensor

- 1 - Install the phase sensor support onto the oil pump case. Tighten the screws to 10 Nm.

Caution - Warning

When installing, be careful not to damage the phonic wheel by knocking it against the oil pump.

- 2 - Install the phase sensor onto the support and tighten the screws temporarily.

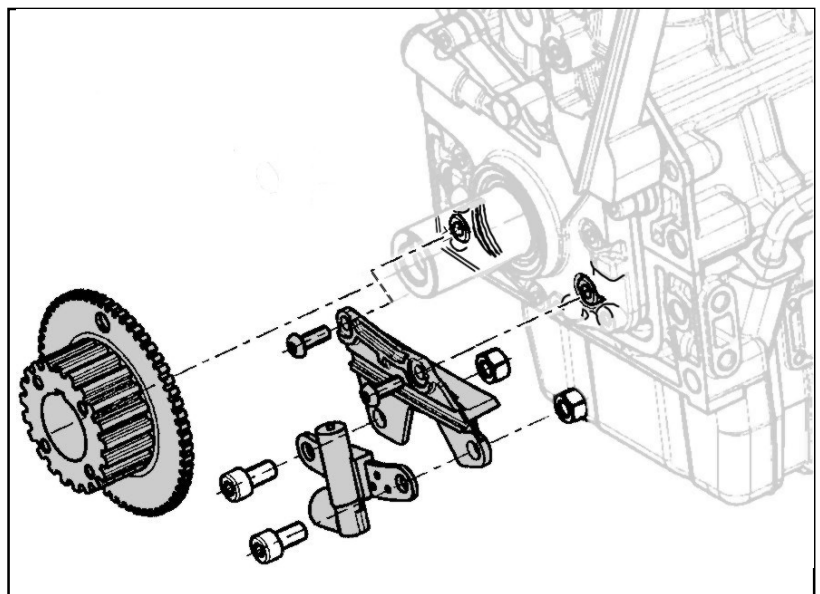

7.7.2 Assembling the timing belt pulleys (camshaft and crankshaft)

- 1 - Insert the key (B) into the crankshaft.
- 2 - Install the pulley (A).
- 3 - Mount the pulley (C) and tighten the screw to a torque of 80Nm.

Important

To ensure the correct timing, line up the reference notches on the pulley (A-C) with the respective gear timing notches (X-Y).

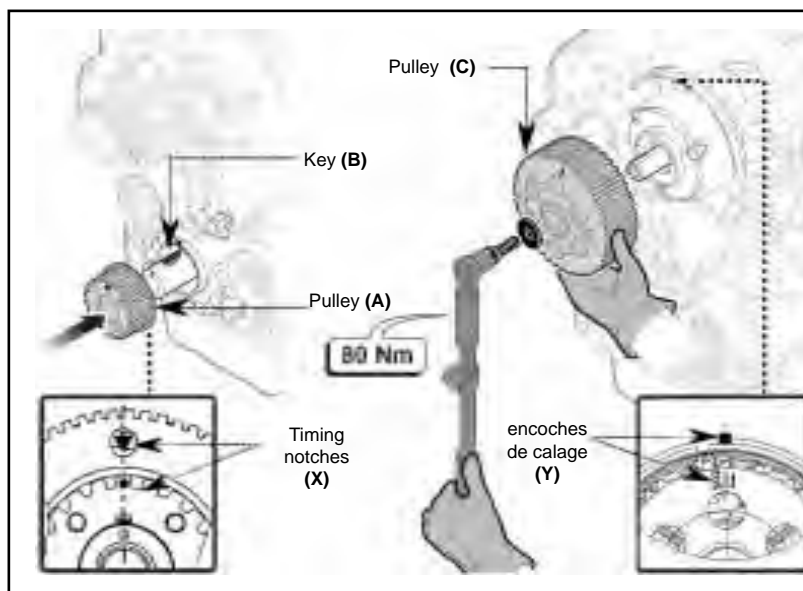

7.7.3 Adjusting the phase sensor

- 1 - Regulate the distance with the phonic wheel (installed on the timing control pulley), to 0,45±0,55.

Important

The air gap (0.5) between the speed sensor and the phonic wheel must be adjusted on the largest tooth.

- 2 - Tighten the speed sensor's fastening screws to a final torque of 10Nm.
- 3 - Connect the cabling and secure with a heat-shrink sleeve.
- 4 - Heat the heat-shrink sleeve using an air heater to ensure that the connections are totally waterproof.



7.7.4 Assembling the synchronous timing belt

- 1 - Insert the belt into the pulley (C). Keeping it taut, insert into pulley (A).

Important

Keep reference arrows directed as shown in the figure.

– The timing belt must always be replaced with an original spare part whenever it is removed.

- 2 - Keep the belt inserted into the two pulleys and then mount it onto the pulley nut (F) and the pulley (E).
- 3 - Tauten the belt using the pulley nut (F) and fasten temporarily.

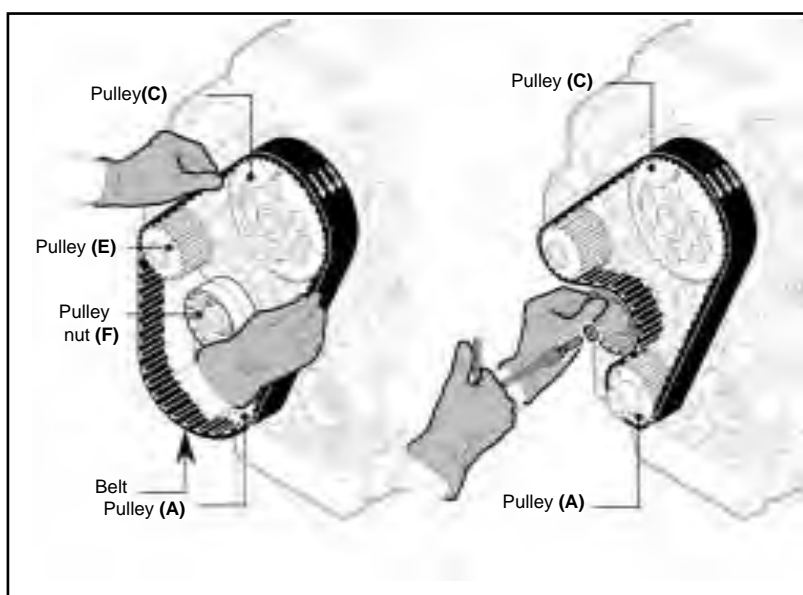

Important

To maintain engine timing while the timing belt is being installed, keep it slotted onto the two pulleys (A-C), which must remain lined up with their timing notches.

- 4 - Insert tool «7107-1460-049» into the lever on the pulley nut support.
- 5 - Set the torque wrench to 20 Nm and insert it into the tool, with the lever perpendicular to the belt.
- 6 - Loosen the nut slightly (D).
- 7 - Turn the tool clockwise to a torque of 20 Nm. Maintaining this torque, lock the nut (D) to 40 Nm.

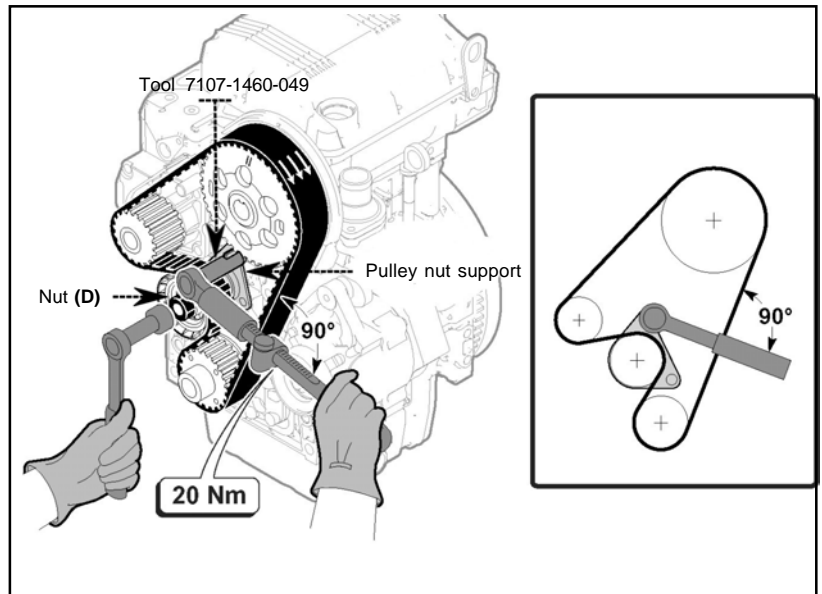

- 8 - Tighten the nut (D) to a final torque of 40Nm.
- 9 - Install the pulley (G1).
- 10 - Rotate the crankshaft a few times to settle and position the belt correctly.
- 11 - Before doing so, make sure that the pulley notches (crankshaft and camshaft) are lined up with their respective timing notches.
- 12 - If belt tension is not satisfactory, repeat the operations described above .
- 13 -Disassemble the pulley (G1).

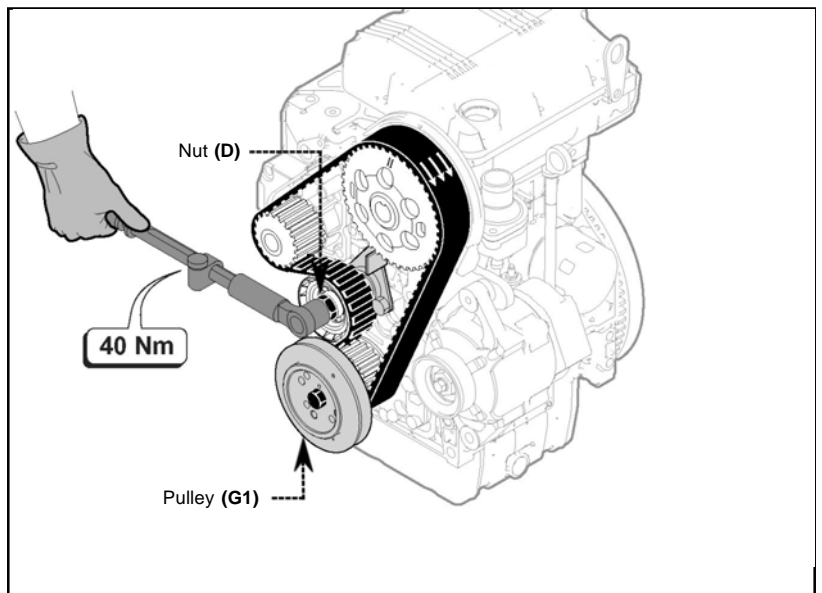

Important

If checking with a ND Denso tension gauge (halfway along the longest branch of the belt) the cold engine value should be 15±2Kg.

7.7.5 Assembling the timing belt guard

- 1 - Mount the guard (G) without tightening the screws completely
- 2 - Tighten the screws in alternating order to a final torque of 10Nm.

Important

If replacement of the optional dust guard rings (H-H1) and the peripheral sleeve becomes necessary for technical or construction reasons, please request the pre-assembled guard (G) complete with rings and gaskets.

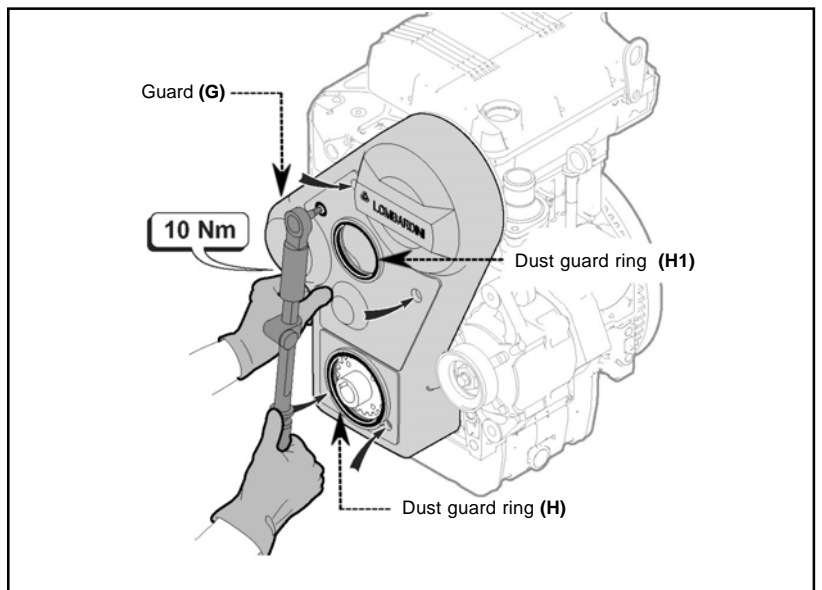

7.8 INSTALLATION OF THE COOLING FAN BELT DRIVE
7.8.1 Assembling the cooling fan belt drive pulleys

- 1 - Check that all components are intact and, if necessary, replace them with original spares.
- 2 - Mount the pulley **(G1)** and fasten the screws **(4)** without tightening them.
- 3 - Tighten the screws in crisscross order to a final torque of 10Nm.

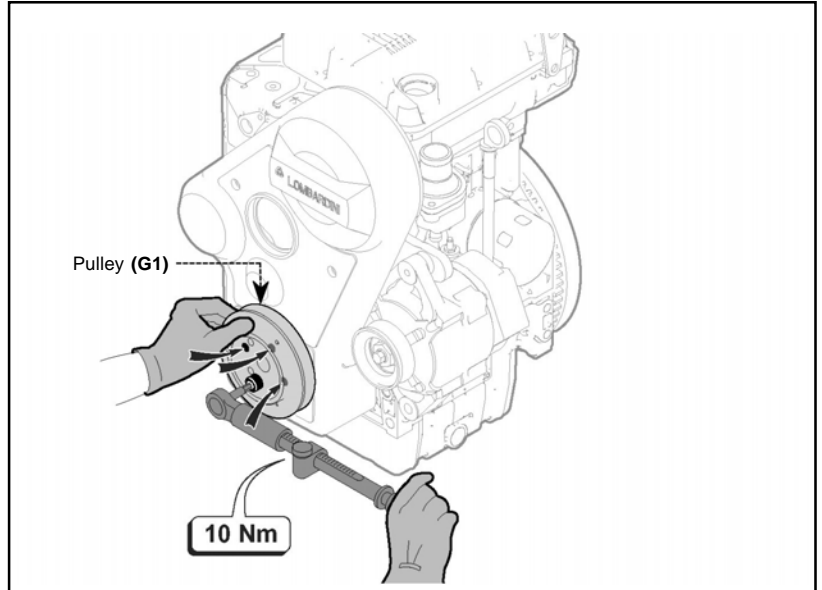

- 4 - Install tool «7107-1460-051» to inhibit rotation of the crankshaft.
- 5 - Apply some anti-seize product to the screw thread **(L)**.



Caution - Warning

The screw is left-handed. Turn anticlockwise to tighten.

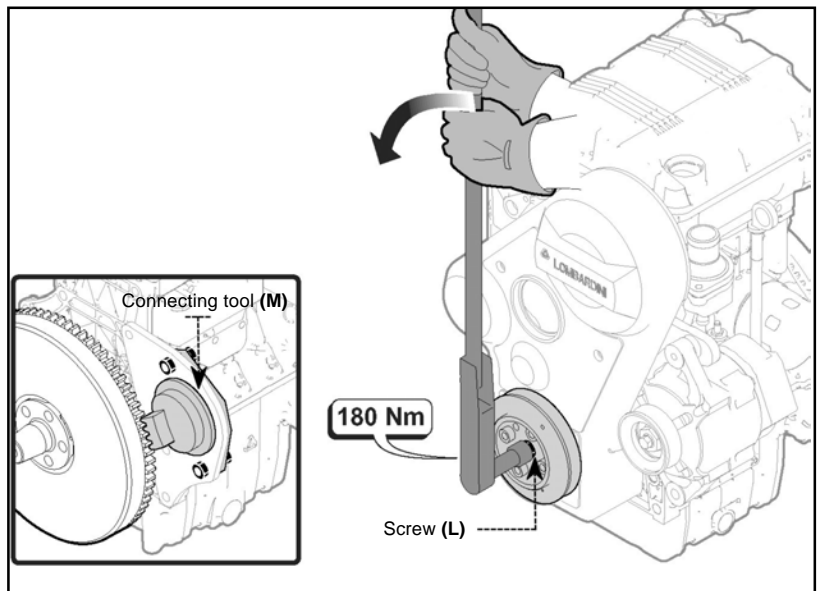
- 6 - Tighten the screw **(L)** to a torque of 180Nm.

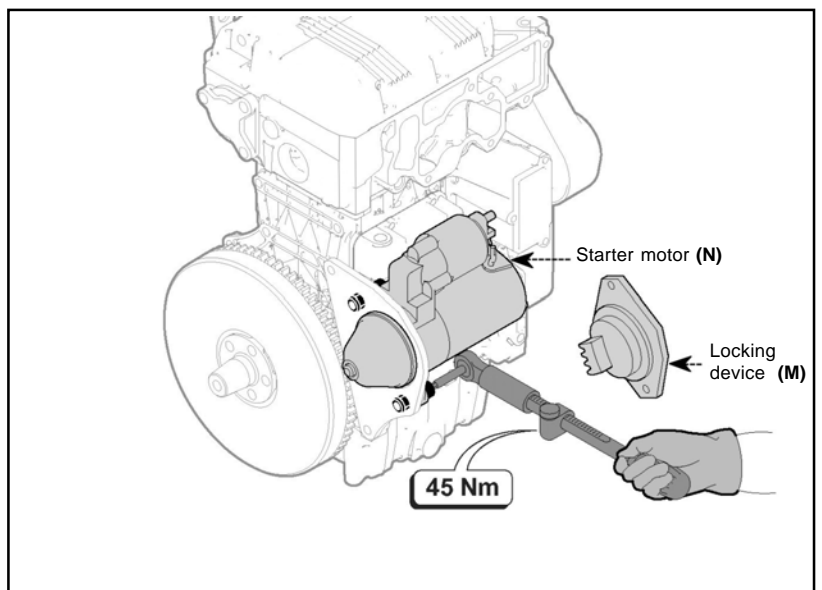

- 7 - Remove the locking tool **(M)**.
- 8 - Install the starter motor **(N)** and tighten the screws to a torque of 45 Nm.



- 9 - Mount the modular pulley (P), its washers and spacers.
- 10 - Tighten the screw (Q) to a torque of 25Nm.

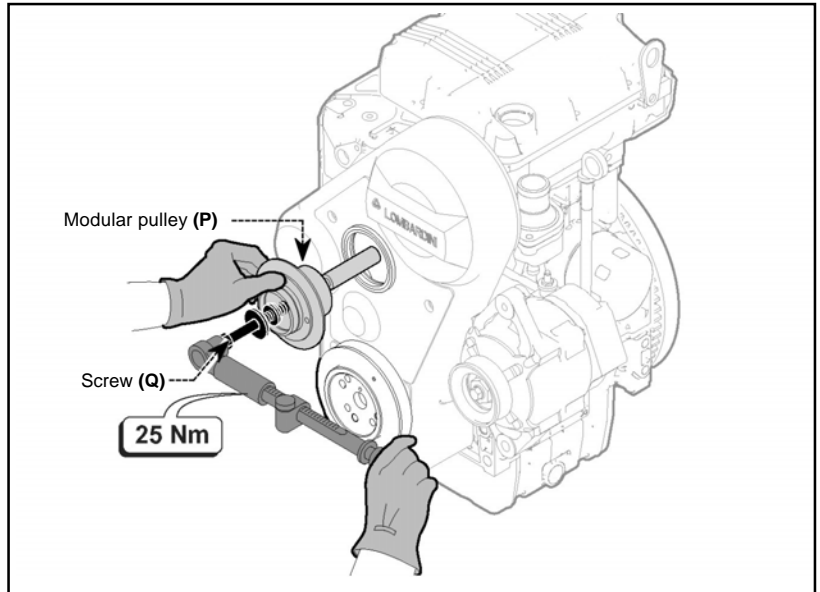

7.8.2 Assembling the cooling fan belt (with internal alternator)

- 1 - Install the belt, flange and the pulley hub (R).
- 2 - Manually rotate the crankshaft to make sure the belt is fitted correctly.
- 3 - Tighten the screws to a torque of 10Nm.-
- 4 - Adjust belt tension.

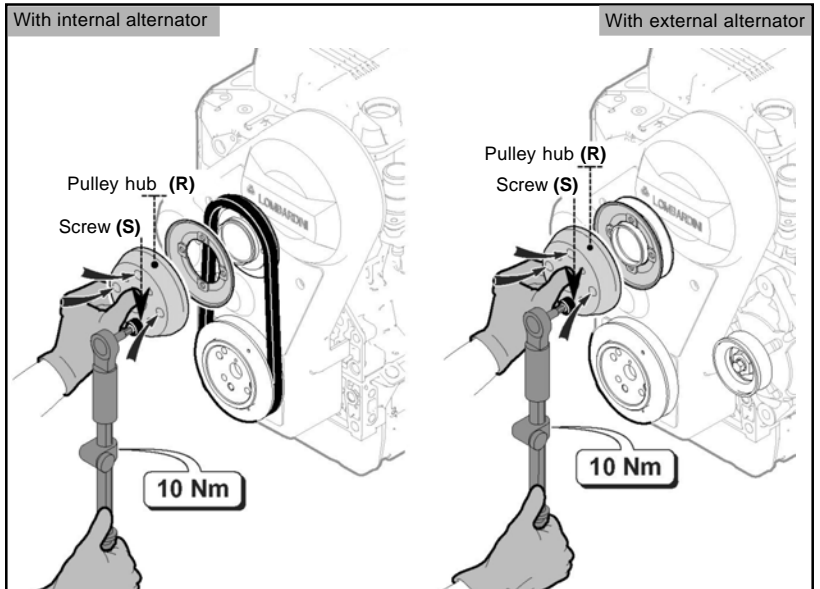

Important

- Use the method shown in the figure to check belt tension. The resultant (R) must be 10-15mm.
- If the belt is too tense, insert a spacer between the flange and the pulley, or remove a spacer if it is too slack.

- 5 - Install the cooling fan.
- 6 - Tighten the screws to a torque of 10Nm

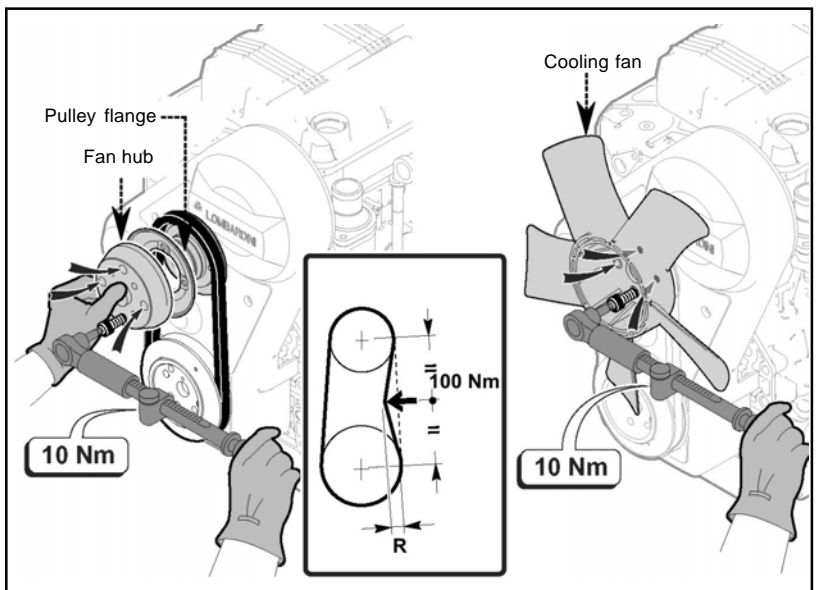

7.8.3 Assembling the cooling fan belt (with external alternator)

- 1 - Install the flange and the pulley hub (R).
- 2 - Tighten the screws to a torque of 10Nm.
- 3 - Install the belt (T).

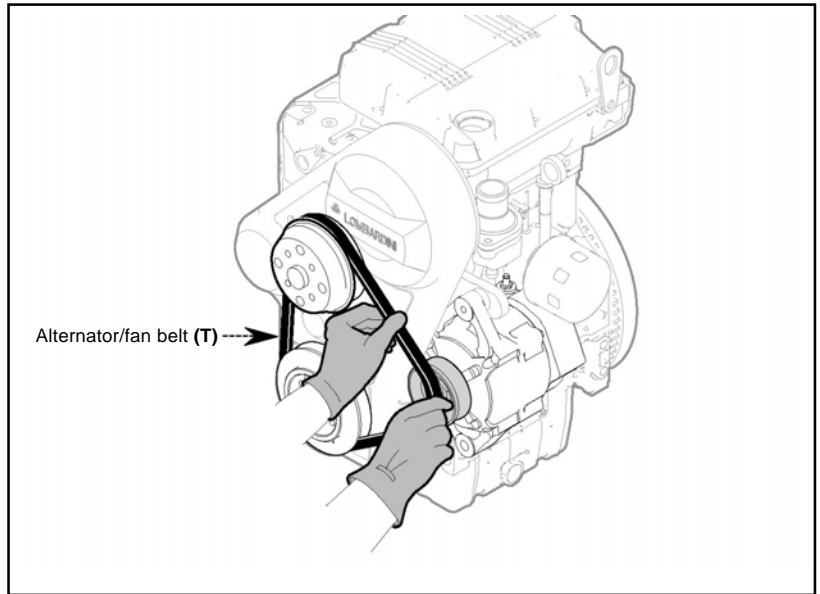

- 4 - Adjust the alternator manually while at the same time tightening the screw to regulate belt tension.

Important
Use the method shown in the figure to check belt tension. The resultant (R) must be be 10-15mm.

- 5 - Tighten the nuts (B-B1) to a final torque of 40 and 25Nm respectively.

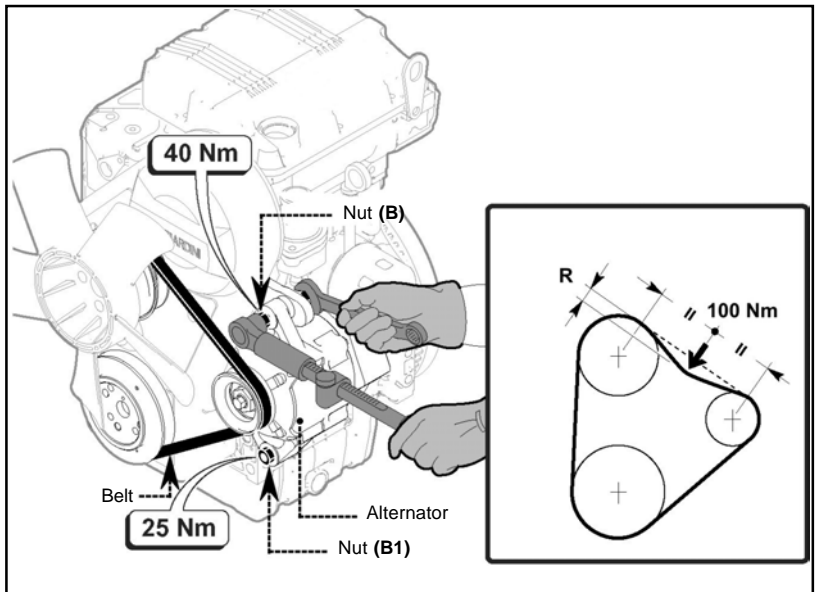

- 6 - Install the cooling fan (U).
- 7 - Tighten the screws to a torque of 10Nm.

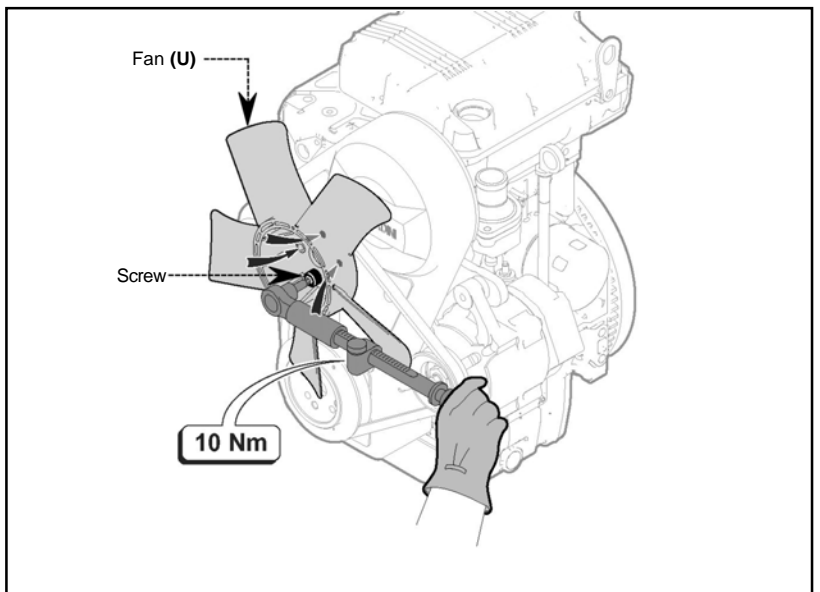

7.9 INSTALLING INTAKE AND EXHAUST MANIFOLDS

7.9.1 Assembling the throttle and sensors

Components:

- 1 Intake manifold
- 2 Throttle body
- 3 Nut
- 4 Throttle body gasket
- 5 Stud bolt
- 6 Absolute pressure sensor
- 7 Air temperature sensor
- 8 Plug

- **Installing the absolute pressure sensor**
Drive in the sensor, remembering to lubricate the O-ring.
- **Installing the air temperature sensor**
Drive in the sensor, remembering to lubricate the O-ring.
- **Installing the throttle body**
Install the throttle (2) with the gasket (4), and tighten the nuts (3) to a torque of 10 Nm.

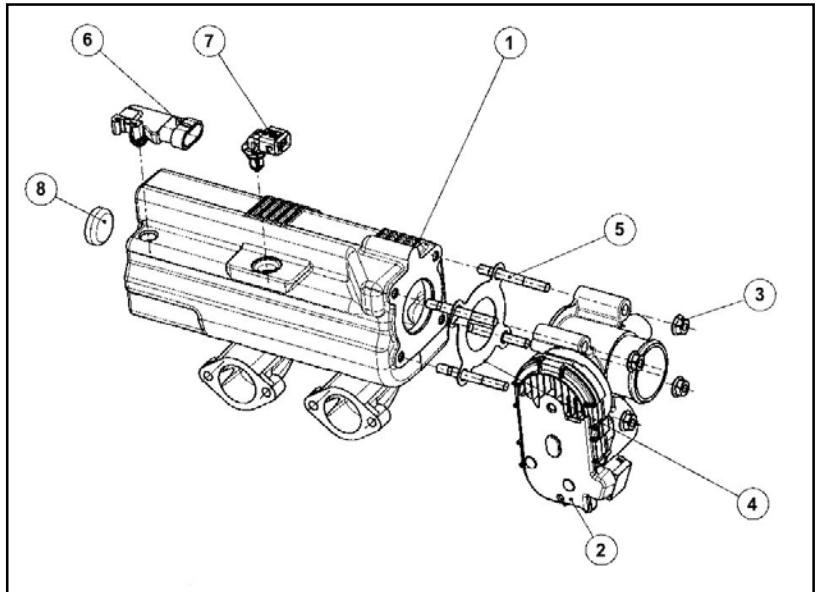

7.9.2 Assembling the intake manifold

- 1- Make sure that the manifold ducts and surfaces are
- 2- Eliminate any blockages from the ducts.
- 3- Seal off the cylinder head and intake manifold ducts with gaskets

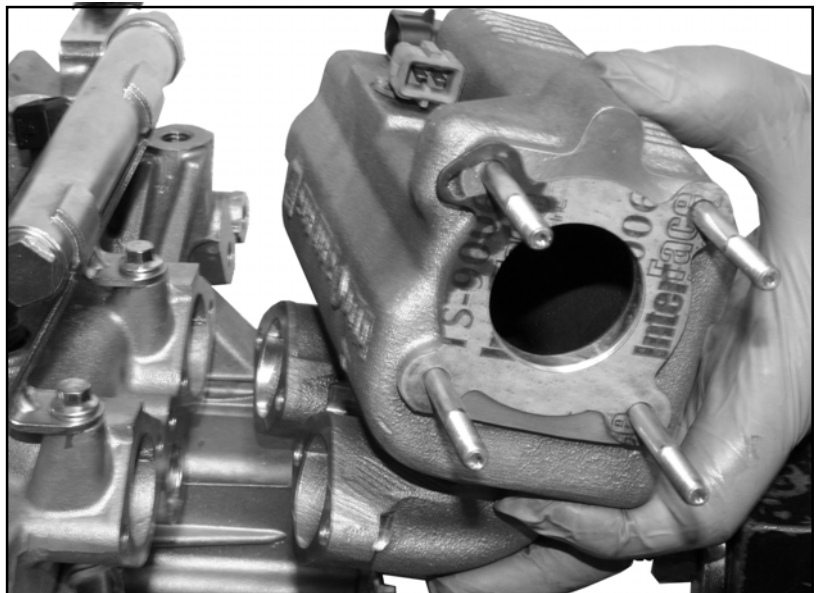

- 4- Install the coil support complete with coil.
- 5- Install the intake manifold without tightening the screws.
- 6- Tighten the screws in an alternating pattern to a final torque of 10Nm.
- 7 - Connect the spark plug and coil power supply cables.

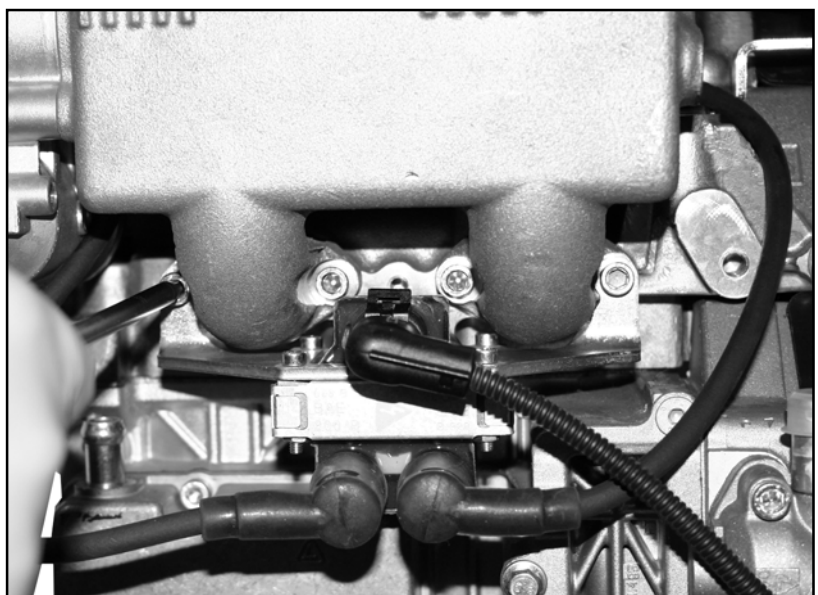

8 - Connect the connector **(F)** to the absolute pressure sensor and connector **(F1)** to the temperature sensor.

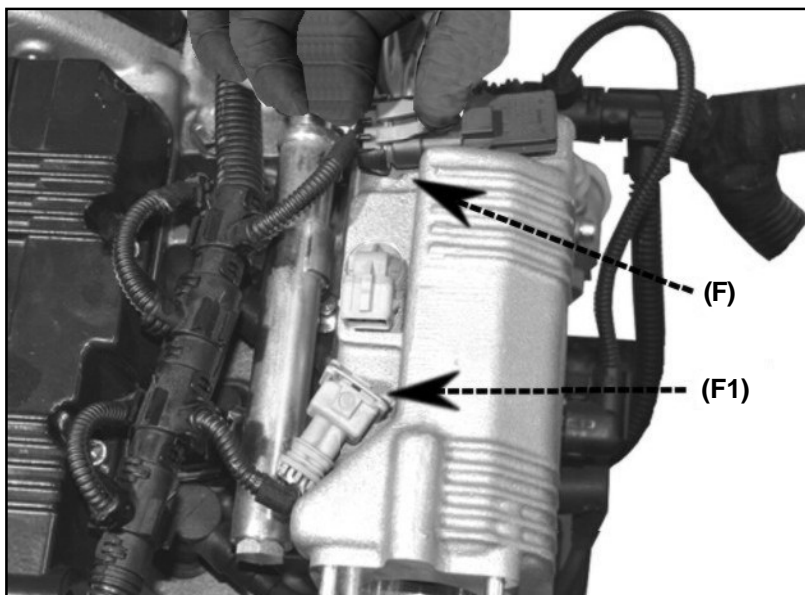

9 - Connect the connector **(D)** to the throttle body **(E)**.

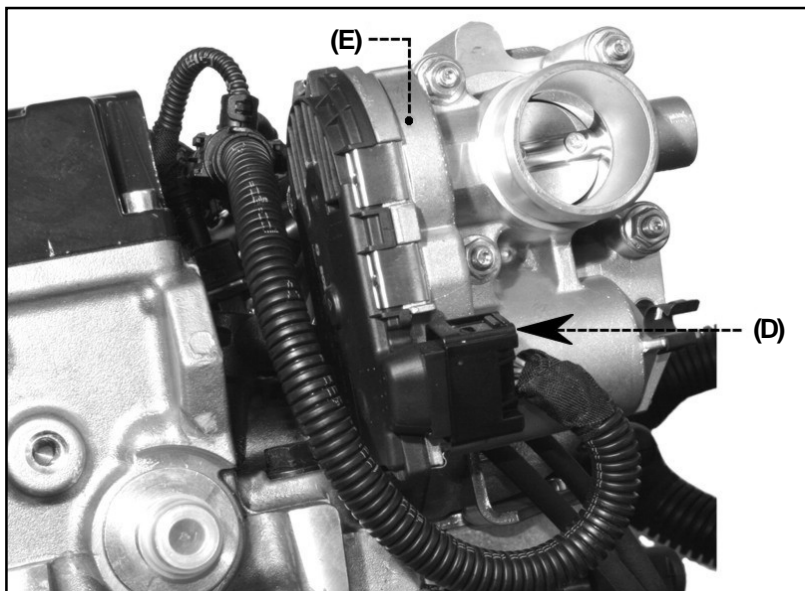

10 - Install the air filter support.
 11 - Fit the air filter hose **(C)** to the throttle body.
 12 - Connect the breather pipe **(B)**.
 13 - Tighten the clamps on the air filter manifolds and the breather.

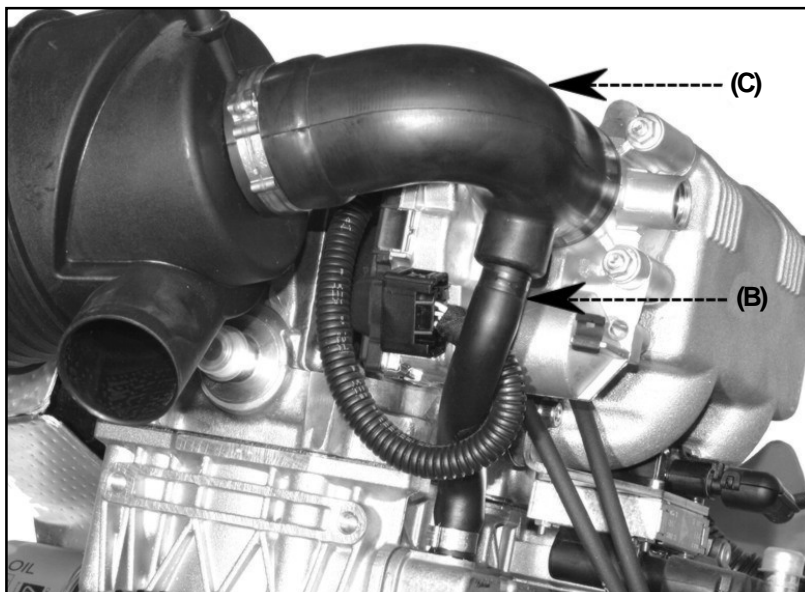

- 13 - Connect the clamp **(A)** to the air filter support **(S)**.

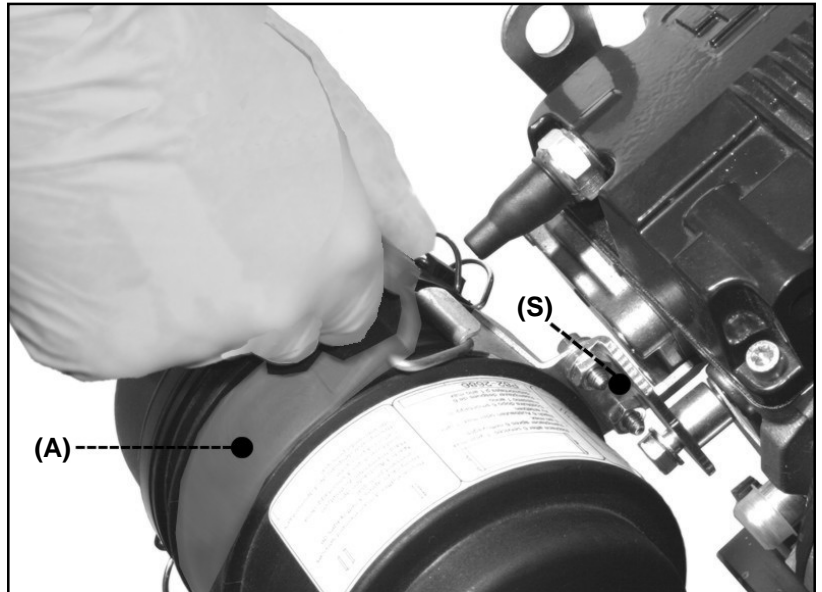

7.9.3 Assembling the exhaust manifold

- 1 - Make sure that the manifold ducts and surfaces are clean and unbroken.
- 2 - Eliminate any blockages from the ducts.
- 3 - Place the gaskets between the manifold and the cylinder head.
- 4 - Install the exhaust manifold.
- 5 - Tighten the screws in alternating order to a final torque of 25Nm.

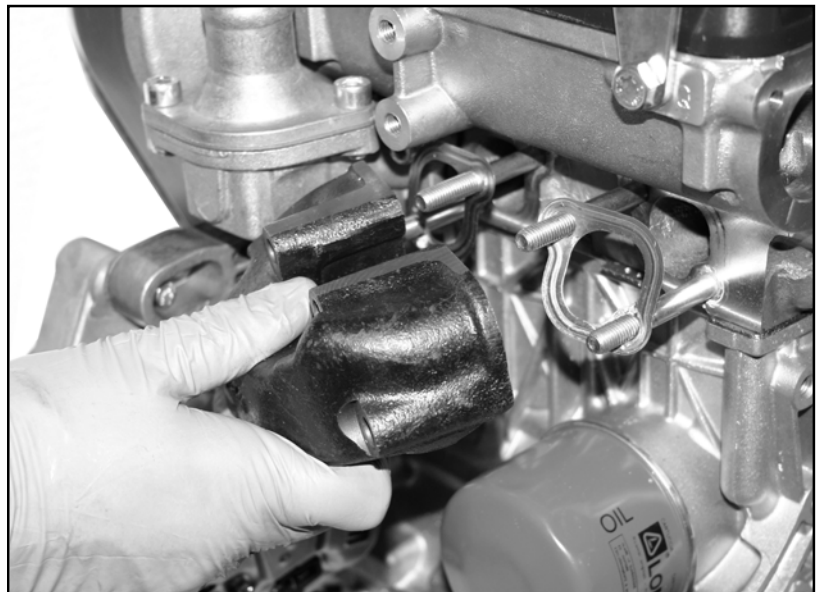

- 6 - Connect the breather pipe to the manifold.
- 7 - Install the Lambda probe and fasten it to a torque of 50 Nm.

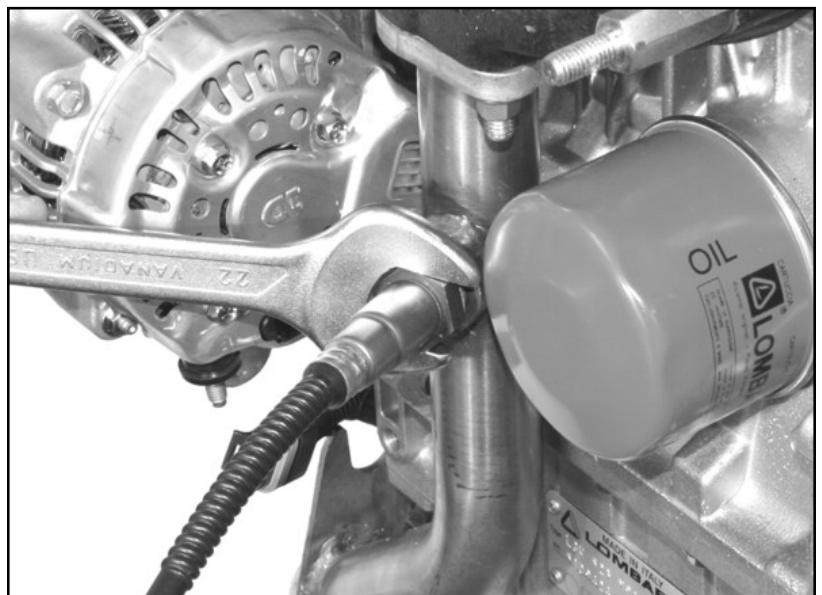

8 - Install the thermal protection.



Caution - Warning

Do not start the engine when the thermal protection is not in place.



9 - Install the case holding the dipstick.

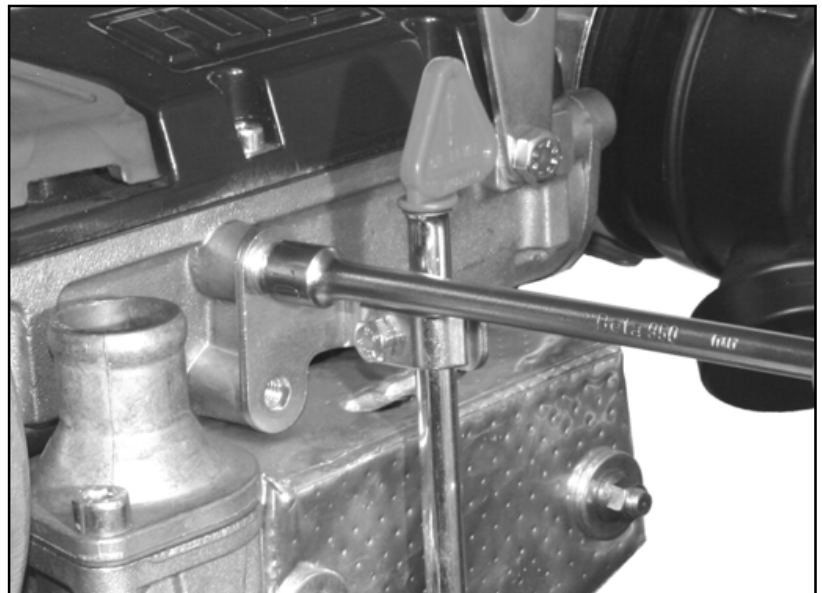

8.1 VEHICLE CONTROLS



Important

- Before starting the diagnostic procedure, it is absolutely necessary to carry out the preliminary checks described below, as well as any required operating measures.
- The diagnostic procedure must begin systematically with an analysis of the symptoms of malfunctioning.



Danger - Attention

Use of this procedure requires preliminary knowledge of how the injection system works.

8.1.1 Preliminary checks

Operate with:

- Starter circuit in good condition: battery, wiring and starter motor.

- Sufficient quantities of the correct fuel.
- Fuel filter clean and properly installed.
- Well-sealed and unobstructed oil steam return pipes.
- Well-sealed and unobstructed fuel steam return pipes.
- Air supply circuit:: pipes sealed, small parts sealed (manifold gaskets, throttle box etc.), air filter clean and properly installed, collars tightened.
- Accelerator cable adjustment: return in minimum position and max opening of throttle from accelerator pedal.
- Engine in good mechanical condition (compression, valve clearance, timing system and cylinder head gasket in good condition).
- Spark plugs are in good condition and conform to requirements.

8.2 COMPONENTS LAYOUT INSIDE THE ENGINE CASE

Installations may differ from brand to brand and vehicle model to mode.



Important

Disconnect the negative wire of the battery every time work is carried out on the vehicle.

- 1 Diagnostic connector
- 2 Fuel union
- 3 Accelerator cable adjustment screw
- 4 Accelerator cable
- 5 Accelerator sensor
- 6 Accelerator connector
- 7 Electronic control unit (ECU)
- 8 Ignition system relays and fuses

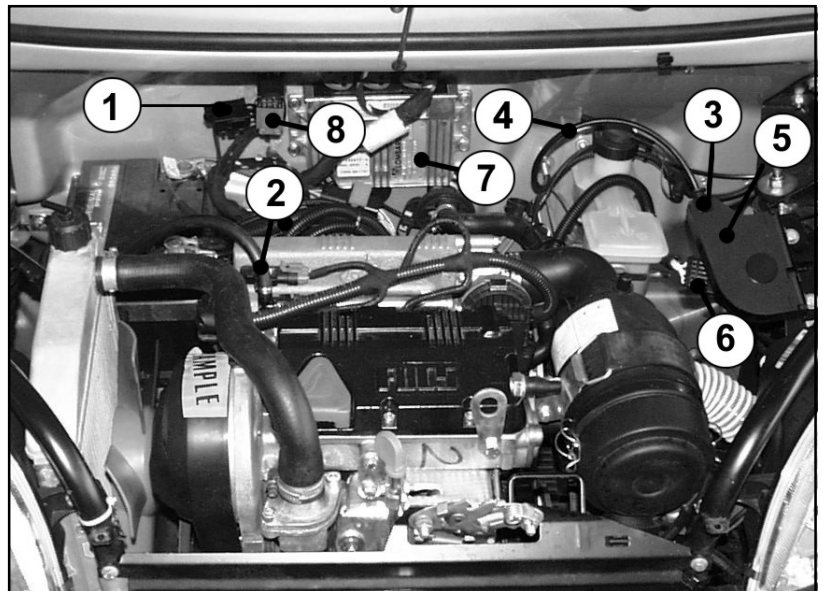

8.2.1 Petrol pressure check



Caution - Warning

To avoid the risk of accident, do not smoke or use any kind of flame when checking the injectors.

- 1 - Disconnect the fuel union from the engine, taking care not to splash petrol.
- 2 - Place a pressure gauge on the fuel supply pipe from the tank to the engine.
- 3 - Start the engine and make sure that the fuel pressure inside the fuel pipe reached 3.5 bars.

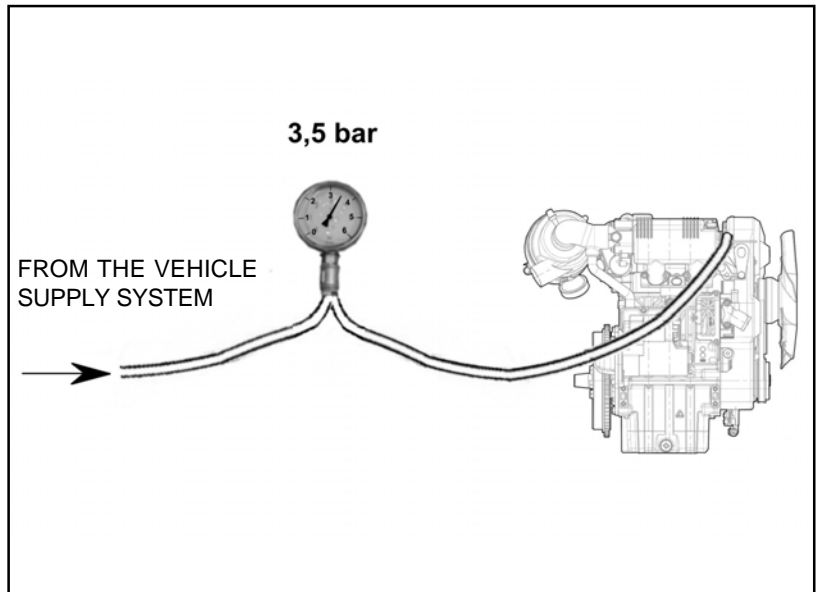

Important

In the event of prolonged disuse of the vehicle, the fuel pressure may be 1.5 bars, however reactivation of the fuel pump (turning the ignition key to «I» 15/ 54), should bring the pressure to the set value.

- 4 - If pressure is below 3.5 bars, check and, if necessary, replace the overpressure valve, the fuel pump or the fuel filter.

8.2.2 Injector check

- Resistance

Disconnect the connector from the injector; use an ohmmeter to measure the resistance between the injector pins; resistance should be approximately 12 Ohms, otherwise replace the injector and reconnect the connectors.



Danger - Attention

To avoid the risk of accident, do not smoke or use any kind of flame when checking the injectors.



- Delivery

- 1 - Remove the fuel pipe complete with injectors from the vehicle.
- 2 - Disconnect the fuel union, taking care not to splash petrol.
- 3 - Connect the petrol union from the vehicle to the pressure gauge (no. 1 in figure) .
- 4 - Connect the petrol union on the instrument to the vehicle fuel pipe (2) complete with injectors (3). The pressure gauge is important for ensuring the correct operating pressure during testing.
- 5 - Place some graduated measuring tubes (4) beneath the injectors.
- 6 - Turn the ignition key to «I» (15/54).
- 7 - Create a bridge between terminals 87 and 30 on the petrol pump relay (see wiring diagram), to ensure that the petrol pump works even when the engine is not running, and hence at the right operating pressure.
- 8 - Using the right wires, link up the injectors to the battery (no. 5 in figure) to start injection.
- 9 - Measure the injected volume inside the cylinder; after a minute this should be between 53.5 and 58.5cc with a pressure of 3.5 bars.

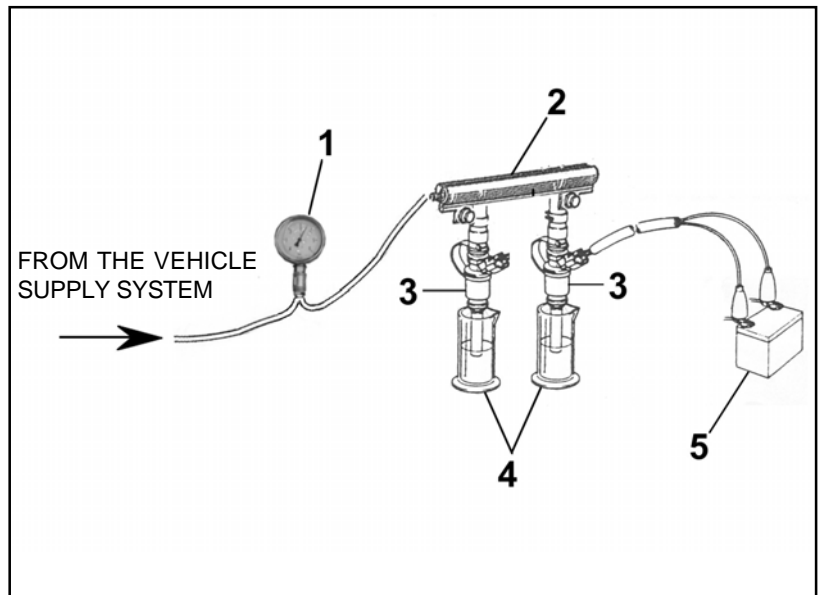

10 - If the injected volume does not correspond to this, replace the injector.

8.2.3 Adjusting the accelerator cable

- 1 - With the accelerator pedal on MIN, the accelerator sensor pulley should stay in contact with the limit stop and the wire should be taut;
- 2 - With the accelerator pedal on MAX, the accelerator sensor pulley should be at a maximum distance of 1.5mm from the limit stop and prevent the pulley from straining too much against the stop.

Turn the adjustment screw (3) to regulate, see «Components layout inside the engine case».

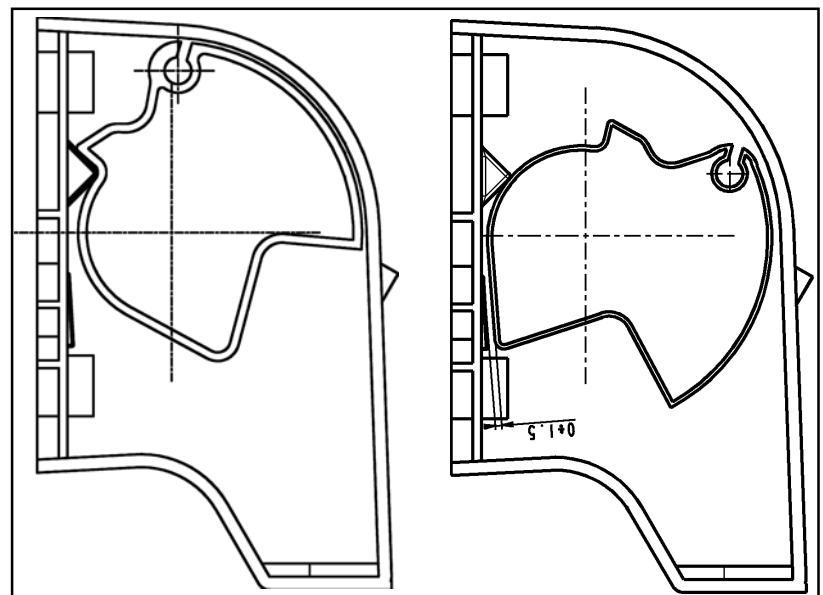

«LIMP HOME» function.



Prudence - Avertissement

In the event of irregularities in a number of components in the engine control system (control unit, throttle body, accelerator sensor etc.), the engine control unit activates the LIMP HOME function, bringing the engine speed to a fixed RPM of 2600-2900 (maximum power ~ 2kW) without the possibility of accelerating or decelerating.

This function is necessary to prevent the danger generated by sudden halting of the vehicle while running, in the event of abnormalities with the components of the electronic engine control system



Danger - Attention

Avoid driving the vehicle in these condition, as it may be very dangerous.

Connect to the Lombardini diagnostic instrument to analyse the problem.

8.3 DIAGNOSTIC



Important

Before proceeding with checks and diagnosis, please see the table of «Parts checks, likely anomalies etc.».

8.3.1 Using the diagnostic procedures

The diagnosis procedure and the controls hereunder described refer only to the vehicles equipped with the Lombardini engine control device and which are in conformity with the origin specifications. The electrical characteristics of the injection system components indicated in the followings pages are the result of measurements carried out with the traditional multi-meter, to which some functions for a specific automotive use have been added.

To obtain a good diagnosis procedure it is absolutely necessary to use the scan tool Lombardini("1460.191 »).

The tool « 1460.191 » is a scan tool instrument that allows to perform the diagnosis on the vehicles with Lombardini engine LGW 523 MPI.

By this instrument it is possible to check the engine functioning parametrers, but it is not possible to change the same.

8.3.2 Technical features

- Supply voltage : 8 ÷ 30 VDC
- Power : 7W max
- Fuse : 1A à rétablissement automatique
- Working temperature : 5 ÷ 40°C
- Connections : Prise D SUB 15 pôles, prise D SUB 9 pôles
- Interfaces : RS232
- Dimensions : 214 x 292 x 63 mm (L x H x P)
- Weight : 1100 g

8.3.3 Total view of the tool

Front view :

- 1 Graphic LCD display
- 2 Keyboard



Cable input view :

- 8 DB9 RS232 Connector
- 9 DB15 diagnostic and supply connector
- 10 IR receiver for remote control

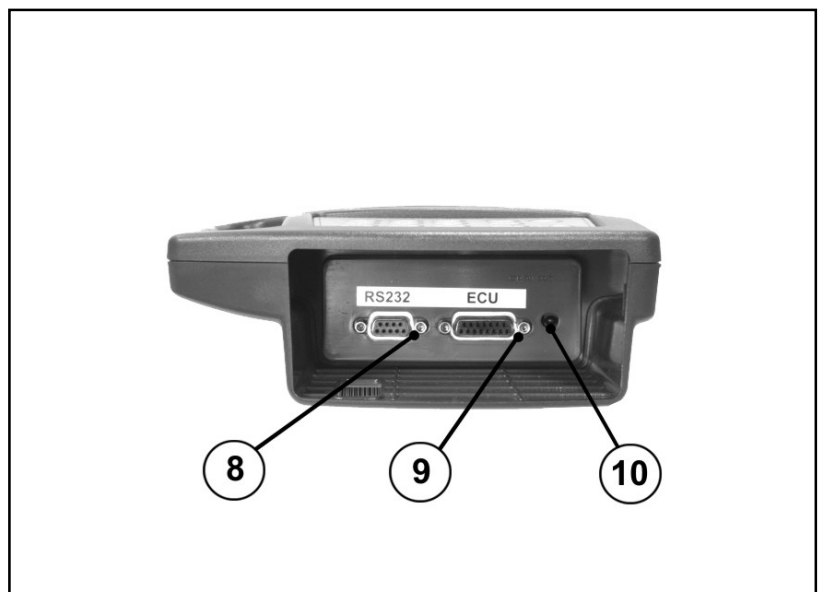

8.3.4 Accessories

Connection cable

1 - Basic cable : it enables the connection with the specific interface cables per vehicle and with the standard cable.



2 - EOBD ECU-030 connector : for the connection between the car ECU and the ST-6000.



8.3.5 Autodiagnostic software

1 - Compact flash : it contains the data bank for the car autodiagnosics.



- 2- Cd-Rom : it contains the software for the autodiagnostic from the PC, the software to program the memory card, wiring diagrams and use instructions.



8.4 PRELIMINARY OPERATIONS

8.4.1 Connection to the vehicle

Connect the scan tool to the diagnostic connector as show arrow in figure see « Components layout inside the engine case ».

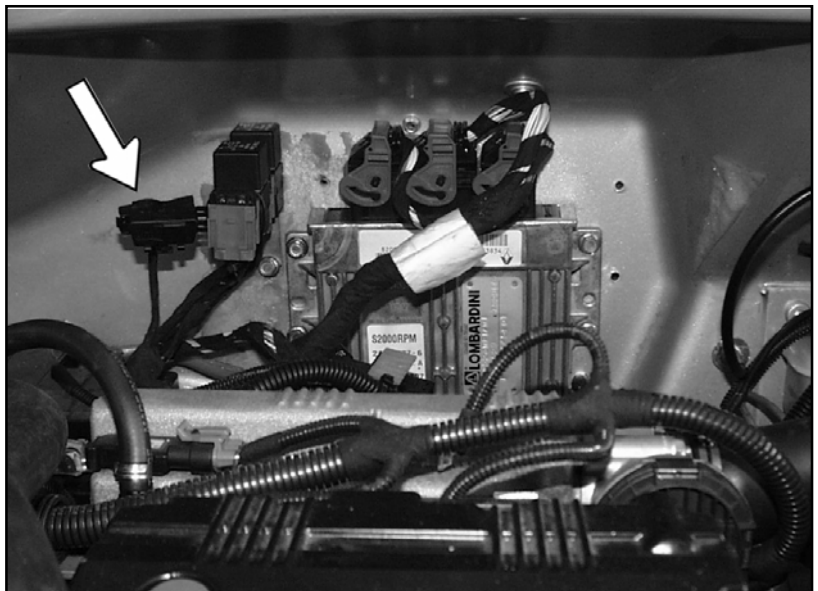



8.4.2 Vehicle and system selection

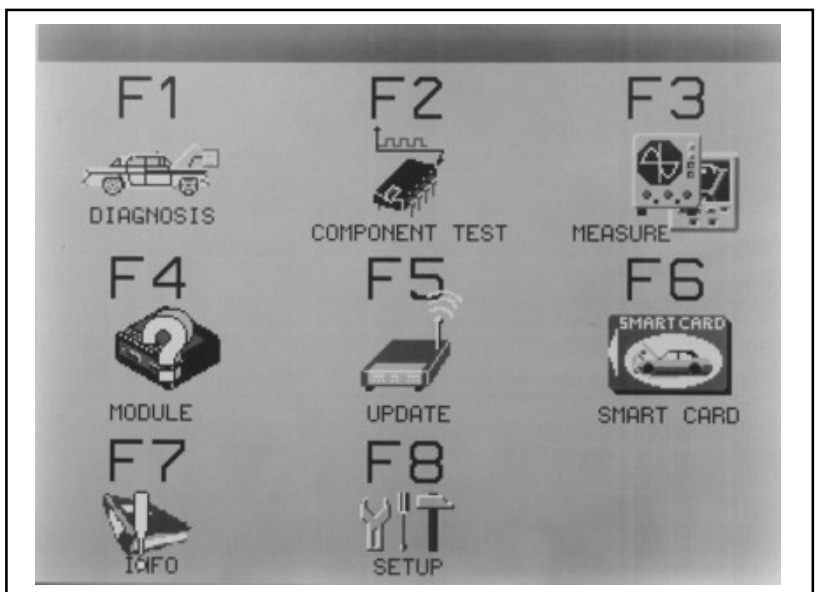

- 1- From the main menu press **F1** « F1 DIAGNOSTIC » to display the type of car selection menu.

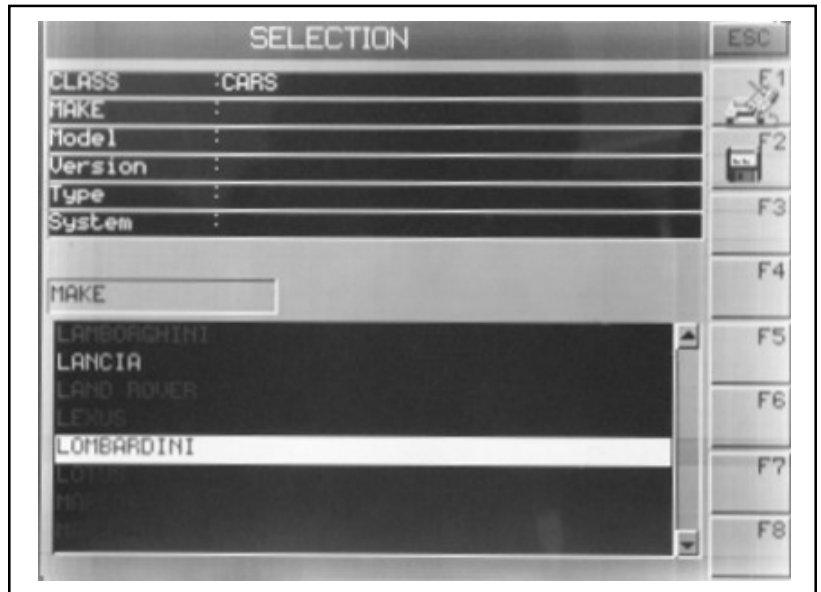

2- By  and  keys select make LOMBARDINI.

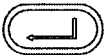

3- Select the model of the car confirming each time by .

4- Select by  and  keys the version and the type of the car confirming each time by .

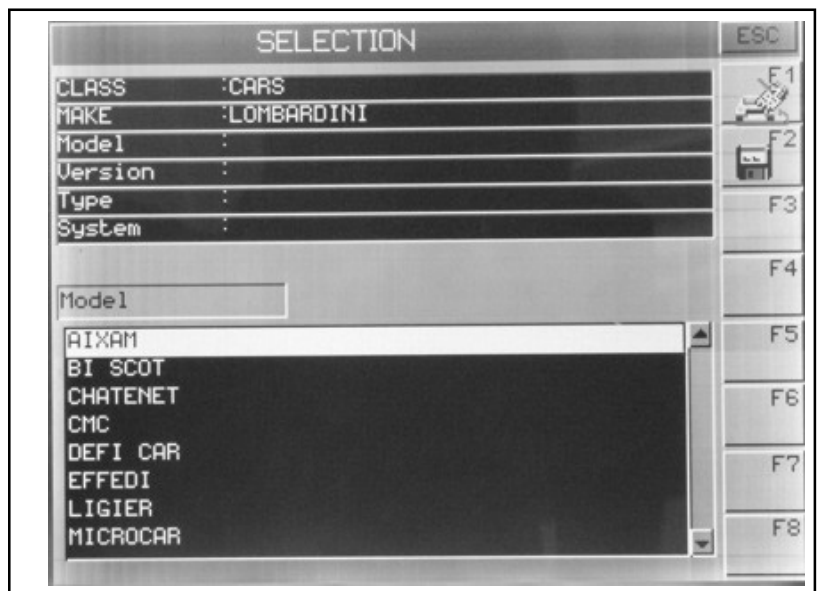

8.5 AVAILABLE FUNCTIONS FOR DIAGNOSTICS

8.5.1 Autodiagnostic

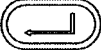
By clicking on  the software for the autodiagnosics will be loaded and it will be asked to connect the tool to the diagnostic connection: connect the instrument as indicated in paragraph «Connection to the vehicle», turn the key on and press OK .

If the dialogue is correctly performed and ECU is recognised, the screen page including the ISO code of the ECU, the spare code and the software version are displayed. éristiques de la boîte, telles que le code ISO, le code de la pièce de rechange et la version du logiciel, apparaît.



- Control that the data correspond to brought back how much on control unit plate « ECU » (see« Control unit identification plate ECU »).

If instead some communication error is detected an error message will be signalled. Press any key to continue.

8.5.2 Detected faults

If the selected vehicle is among those enabled by the smart card, it will be possible to carry out a complete diagnostics: in this case is displayed the LIST OF DETECTED FAULTS.

From this page it is possible to have access to the information contained in the programme by using the menu bar on the right of the LCD display.



8.5.3 Menu bar

ESC. To quit the diagnostic software.

F1 Technical help. It include some information relating to the select component. It is active only when a component is selected.

F2 Information. It gives information on the connected ECU.

F3 Erreurs. It enables the page for the reading of the error codes.

F4 Construction parameters. It enables the page of the construction parameters.

F7 Status. It enables the page that enables the display of the ECU status.

F8 Component test. It enables to carry out special tests on the car electric system components (to be used with the car wiring diagram)

The lack of a button indicates that the relevant task is not supported by the selected system.

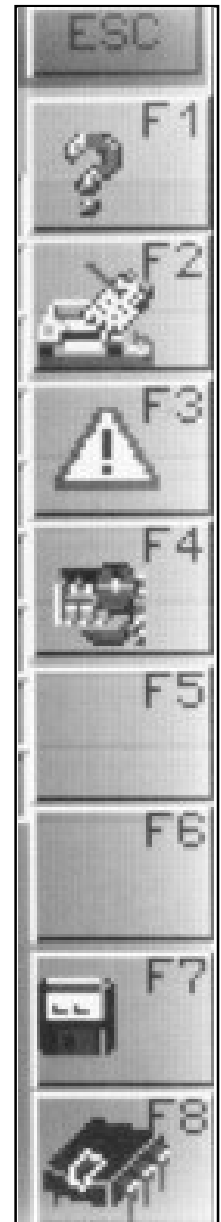

8.5.4 Important to be pointed out before starting

The autodiagnostic level that can be reached by the tool highly depends on the level of evolution of the ECU.

It can happen that some of the function described below are not properly executed.

This does not mean that the tool is not working properly, but simply that the tested system does not support all of the function(for instance in some systems construction parameters or adjustments cannot be displayed).

To know parameters that can be enabled or errors that can be detected see the list of the screen page.

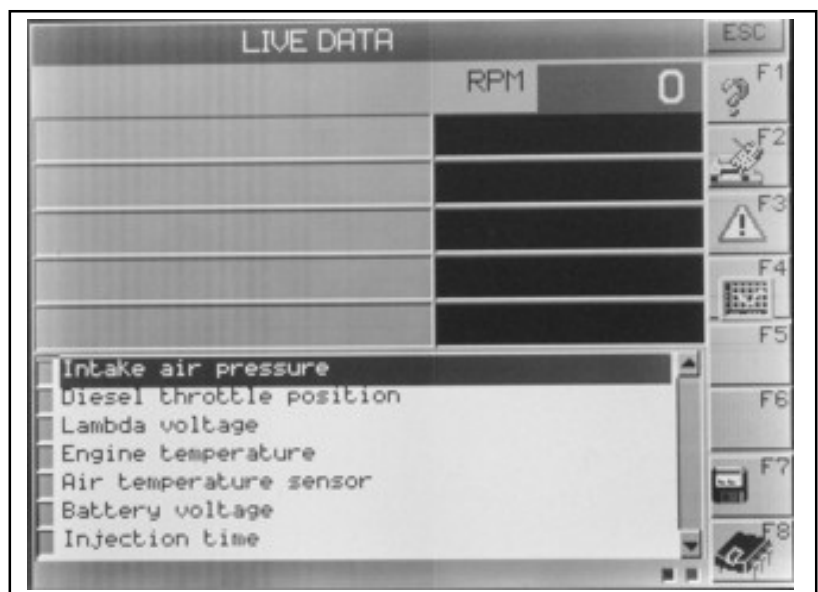

8.6 ERRORS

By clicking on **F3** « F3 ERRORS» it is possible to enter the « **ERRORS** » function that enables the operator to display all the errors that were memorized by the ECU

There are two different kinds of memorized errors:

- The permanent errors (the defect occurs and remains)
- The desultory errors (the defect occurred but it only lasted a short time).

To display the errors that are stored in the ECU

select by or the box and press : the list of errors will be displayed with the relevant icons meaning:

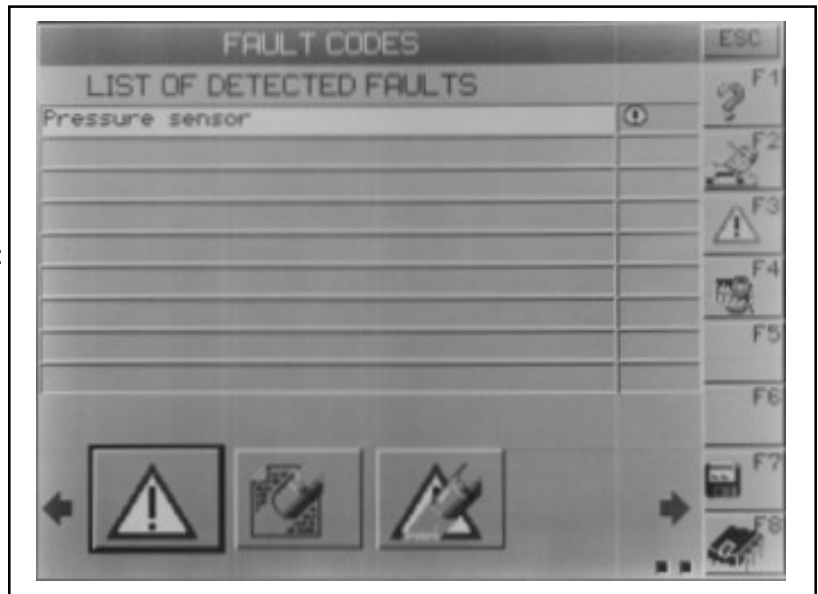

- ERROR MEMORIZED
- ERROR PRESENT
- ERROR MEMORIZED AND PRESENT
- ERASED ERROR

Selecting the error by or and clicking on **F1** « F1 INFO » information on the error are obtained and on the diagnostic strategy.

At the end press **ESC** to go back to the « ERRORS » menu

To cancel the list of errors in the menu select

by keys or the box and press .

This control erases the list displayed in the menu while errors remain in the ECU memory.

To cancel errors memorized in the ECU select

the box by the key or and press * : displayed errors will be accompanied by the icon .

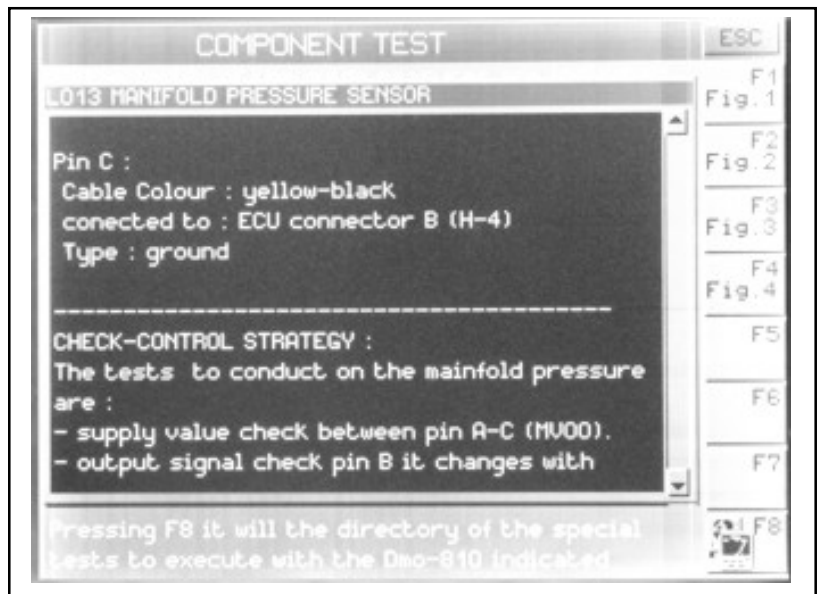

Select the error through or and by pressing « F1 INFO » information on the error and diagnostic strategies are obtained. At the end press to go back to the « ERRORS » menu.

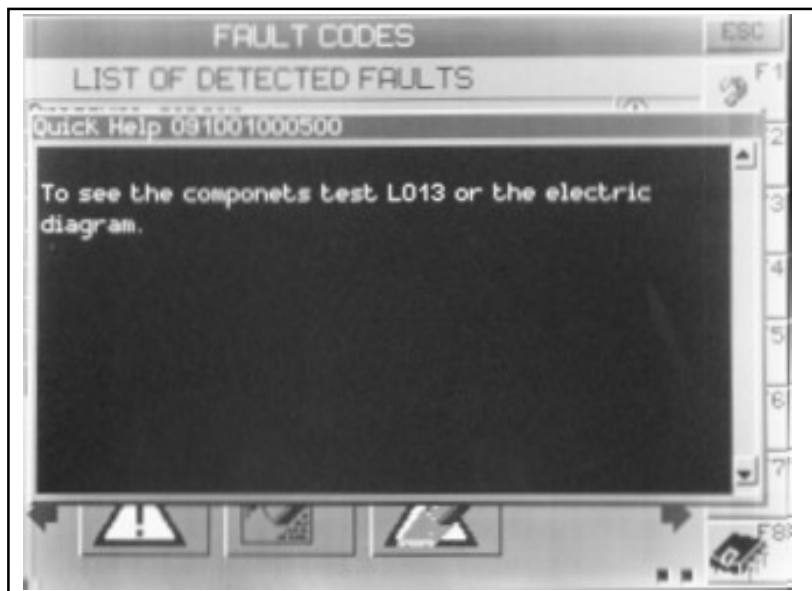

8.7 CONSTRUCTION PARAMETERS

By clicking on « F4 PARAMETRES » key from the menu bar it is possible to enter the «CONSTRUCTION PARAMETRES » function which enables the operator to display all the engine parameters that the ECU can supply.

The monitor displays the page with the list of the parameters concerning the selected system without displaying yet any values.

In order to display the value, by or , position the cursor on the parameter to be selected and confirm the choice by clicking on : the tick mark ✓ will be displayed in the area above.

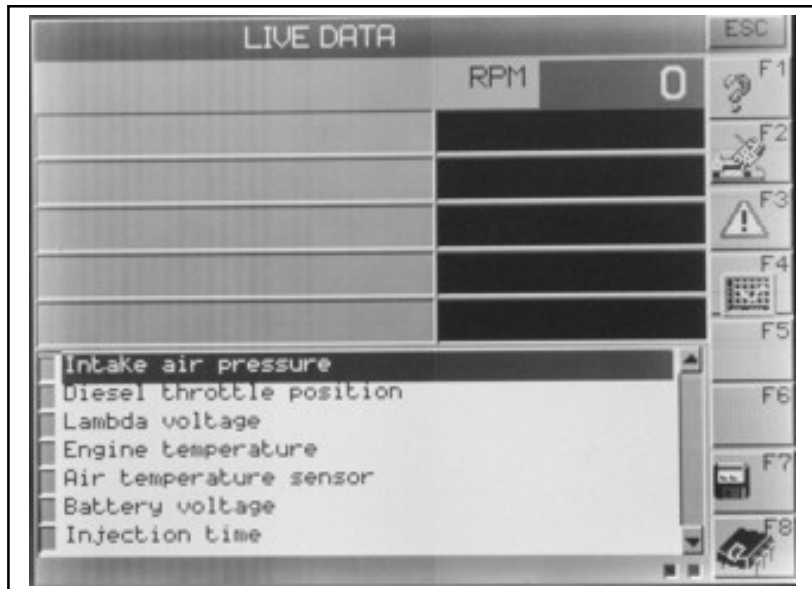



To disable the selection repeat the same procedure. This function enables a quicker parameter updating: as a matter of fact the values updating speed depends on the ECU and on the number of selected parameters.

Important

No more than five parameters can be simultaneously selected, so as not to compromise the display speed.

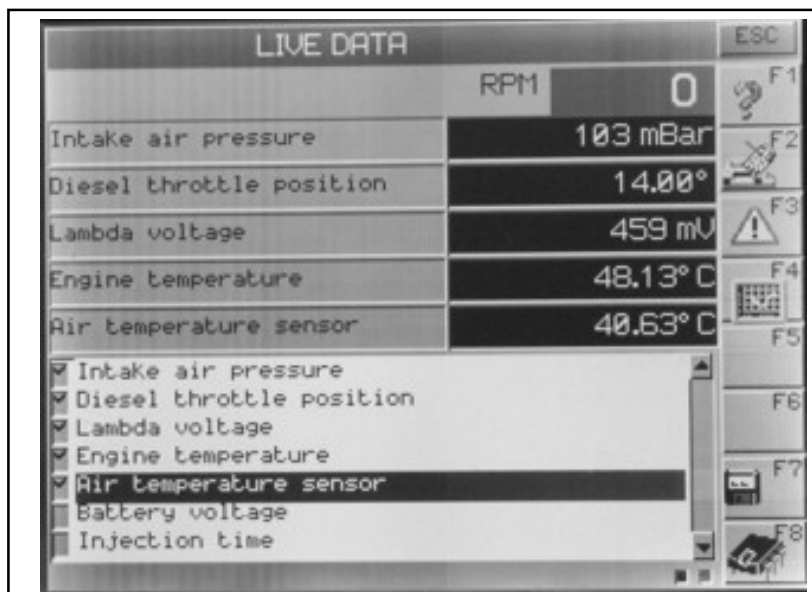
By positioning the cursor on the parameter and by pressing the « F1 INFO » key it is possible to obtain some information about the parameter itself and about the diagnostic strategy.



At the end press  to go back to the «PARAMETRES» menu.

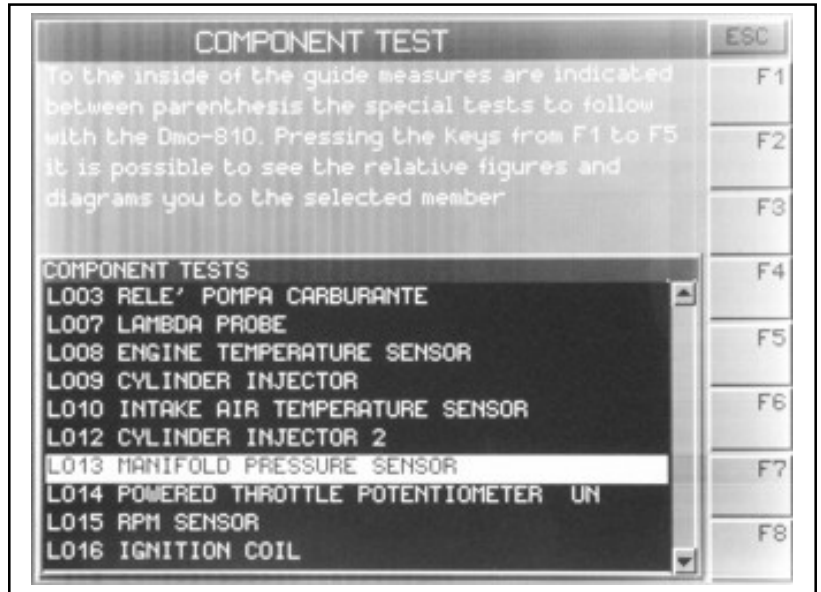



42100 Reggio Emilia – Italia - ITALY
Via Cav. del Lavoro Adelmo Lombardini, 2 - Cas. Post. 1074
Tel. (+39) 0522 3891 - Telex 530003 Motlom I – Telegr.: Lombarmotor
R.E.A. 227083 - Reg. Impr. RE 10875
Cod. fiscale e Partita IVA 01829970357 - CEE Code IT 01829970357
E-MAIL: atl@lombardini.it
Internet: <http://www.lombardini.it>

**La Lombardini si riserva il diritto di modificare in qualunque momento i dati contenuti in questa pubblicazione.
Lombardini se r serve le droit de modifier,   n'importe quel moment, les donn es report es dans cette
publication.**

Data reported in this issue can be modified at any time by Lombardini.

Lombardini vorbeh lt alle Rechte, diese Angabe jederzeit ver ndern.

La Lombardini se reserva el derecho de modificar sin previo aviso los datos de esta publicaci n.

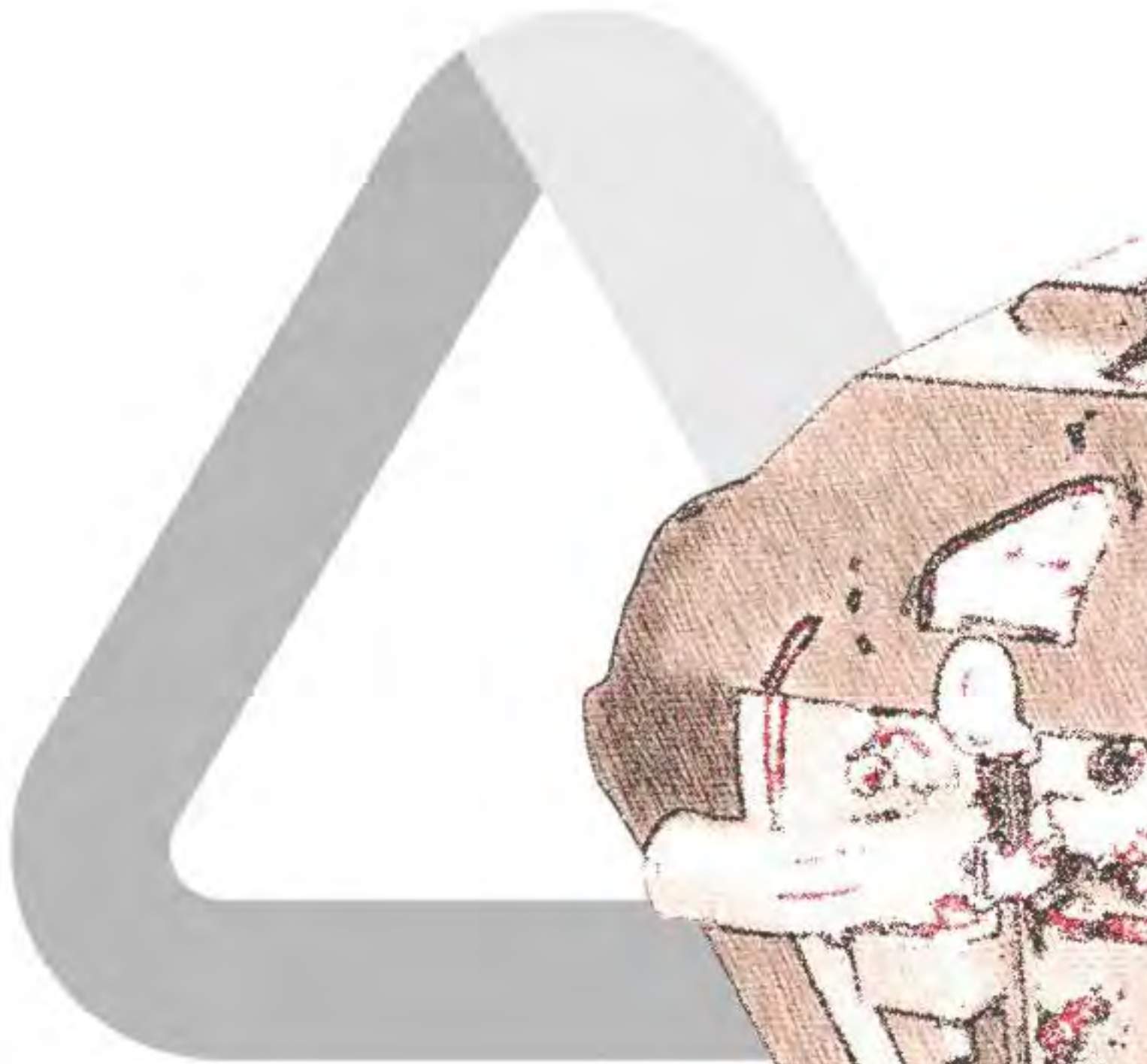

 **LOMBARDINI**

42100 Reggio Emilia – Italia - ITALY
Via Cav. del Lavoro Adelmo Lombardini, 2
Tel. (+39) 0522 3891
E-MAIL: atl@lombardini.it
Internet: <http://www.lombardini.it>

SERVICE MANUAL - code 1.5302.711