

KDI MARINE PROPULSION

40.8 – 74 Hp



 **LOMBARDINI**
Marine

KOHLER® Engines

KDI

1903TCR-MP



Model	KDI 1903TCR-MP	
Engine specs	4-stroke diesel with cylinder in line	•
	Liquid cooling	•
	4 valves per cylinder	•
	In crankcase camshaft, gear train driven	•
	Pushrod - rocker arms timing with hydraulic tappets	•
	Cast-iron crankcase with bedplate	•
	Cast-iron cylinder head	•
Technical features	Closed crankcase ventilation system	•
	Cylinder	3
	Bore (mm)	88
	Stroke (mm)	102
	Engine displacement (cm ³)	1861
	Injection system	DI
	Injection Equipment	Common Rail
Performance	Starting system	Electric starting 12V
	Alternator	12V-120A
	Emission compliance	EU RCD STAGE2
Performance	Max power (IFN - ISO 3046 and ISO 14396) (Hp@rpm)	56@2600
	Max torque (IFN - ISO 3046 and ISO 14396) (Nm@rpm)	225@1500
Physical characteristics	Dry weight without gear (kg)	284
	Daily service points - positions	1 side service
Auxiliary PTOs	Max torque (Nm)	100

DATA

Dimensions (mm)

KDI 1903TCR with TMC260 marine gear

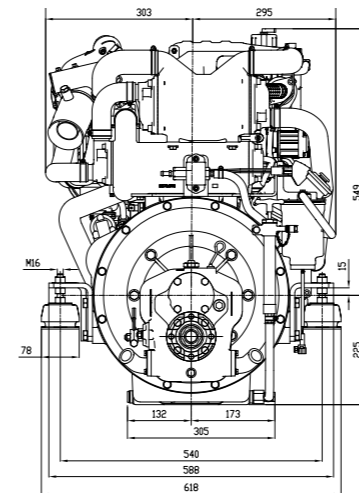
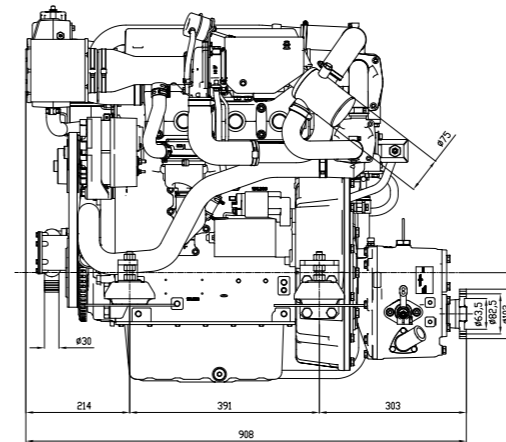

PERFORMANCE CURVES

(ACCORDING TO iso 14396)

KDI 1903TCR-MP

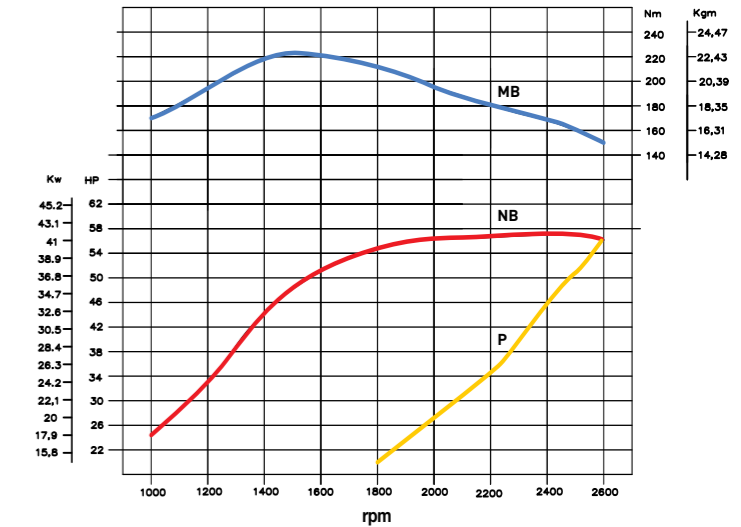

— MB – Torque curve (NB curve)
 — NB – Power curve - ISO 3046/1-IFN
 — P – Propeller demand curve

Power ratings refer to engines equipped with air filter, standard muffler, after running-in period at ambient conditions of +25°C, relative humidity 30% and 1 bar. Power levels drop by 1% every 100 m altitude and by 2% every 5°C above +25°C.

STANDARD EQUIPMENT

- Digital Deluxe-panel
- Alternator 12V - 100A
- Electric starting
- Oil extraction pump
- 100Nm PTO facility
- Exhaust mixing elbow
- Fresh water expansion tank
- Sea water pump front mounted

ACCESSORIES ON DEMAND

- Set of flexible engine mounts
- Hot water take-off kit
- Second station harness and panel
- Oil pressure sensor for Digital Deluxe-panel

KDI

2504TCR-MP



DATA

Dimensions (mm)

KDI 2504TCR with TMC260 marine gear

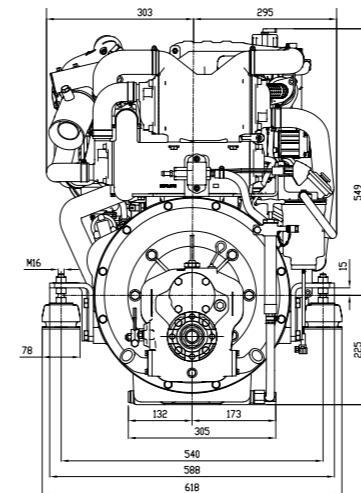
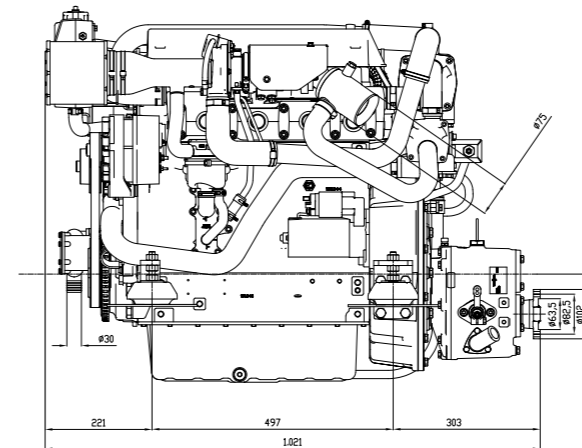

PERFORMANCE CURVES

(ACCORDING TO iso 14396)

KDI 2504TCR-MP

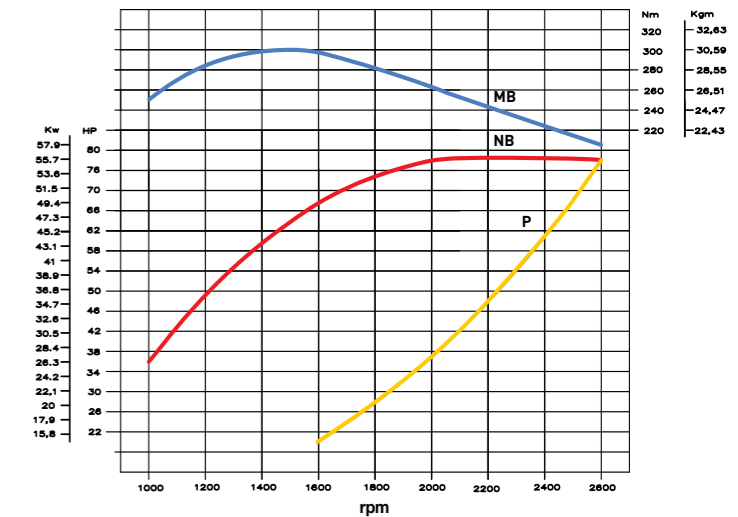

— MB – Torque curve (NB curve)
 — NB – Power curve - ISO 3046/1-IFN
 — P – Propeller demand curve

Power ratings refer to engines equipped with air filter, standard muffler, after running-in period at ambient conditions of +25°C, relative humidity 30% and 1 bar. Power levels drop by 1% every 100 m altitude and by 2% every 5°C above +25°C.

Model	KDI2504TCR-MP	
Engine specs	4-stroke diesel with cylinder in line	•
	Liquid cooling	•
	4 valves per cylinder	•
	In crankcase camshaft, gear train driven	•
	Pushrod - rocker arms timing with hydraulic tappets	•
	Cast-iron crankcase with bedplate	•
	Cast-iron cylinder head	•
Technical features	Closed crankcase ventilation system	•
	Cylinder	4
	Bore (mm)	88
	Stroke (mm)	102
	Engine displacement (cm ³)	2482
	Injection system	DI
	Injection Equipment	Common Rail
Starting system	Starting system	Electric starting 12V
	Alternator	12V-100A
	Emission compliance	EU RCD STAGE2
Performance	Max power (IFN - ISO 3046 and ISO 14396) (Hp@rpm)	74@2600
	Max torque (IFN - ISO 3046 and ISO 14396) (Nm@rpm)	300@1500
Physical characteristics	Dry weight without gear (kg)	323
	Daily service points - positions	1 side service
Auxiliary PTOs	Max torque (Nm)	100

STANDARD EQUIPMENT

- Digital Deluxe-panel
- Alternator 12V - 100A
- Electric starting
- Oil extraction pump
- 100Nm PTO facility
- Exhaust mixing elbow
- Fresh water expansion tank
- Sea water pump front mounted

ACCESSORIES ON DEMAND

- Set of flexible engine mounts
- Hot water take-off kit
- Second station harness and panel
- Oil pressure sensor for Digital Deluxe-panel

KDI

1903M-MP



Model	KDI 1903M-MP	
Engine specs	4-stroke diesel with cylinder in line	•
	Liquid cooling	•
	4 valves per cylinder	•
	In crankcase camshaft, gear train driven	•
	Pushrod - rocker arms timing with hydraulic tappets	•
	Cast-iron crankcase with bed-plate	•
	Cast-iron cylinder head	•
Technical features	Closed crankcase ventilation system	•
	Cylinder	3
	Bore (mm)	88
	Stroke (mm)	102
	Engine displacement (cm ³)	1861
	Injection system	DI
	Injection Equipment	Mech-Rotary pump
Performance	Starting system	Electric starting 12V
	Alternator	12V-120A
	Emission compliance	EU RCD STAGE2
Performance	Max power (IFN - ISO 3046 and ISO 14396) (Hp@rpm)	40.8@2600
	Max torque (IFN - ISO 3046 and ISO 14396) (Nm@rpm)	133@1500
Physical characteristics	Dry weight without gear (kg)	240
	Daily service points - positions	1 side service
Auxiliary PTOs	Max torque (Nm)	100

DATA

Dimensions (mm)

KDI 1903M-MP with TMC60 marine gear

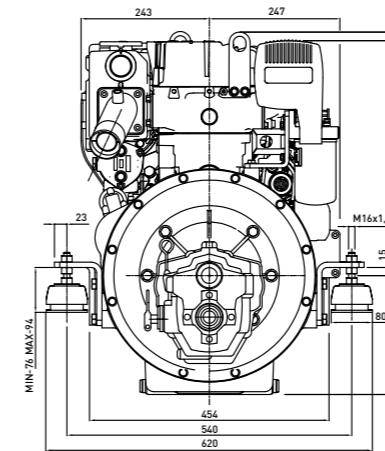
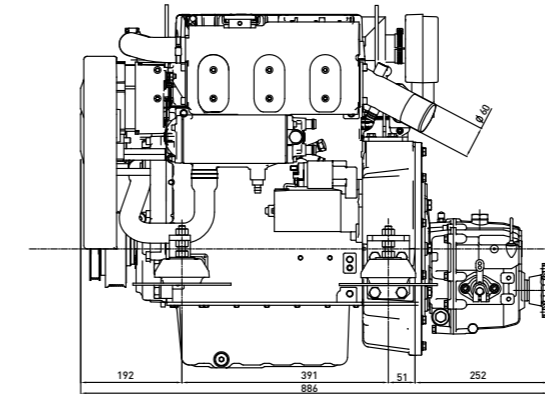

PERFORMANCE CURVES

(ACCORDING TO iso 14396)

KDI 1903M-MP

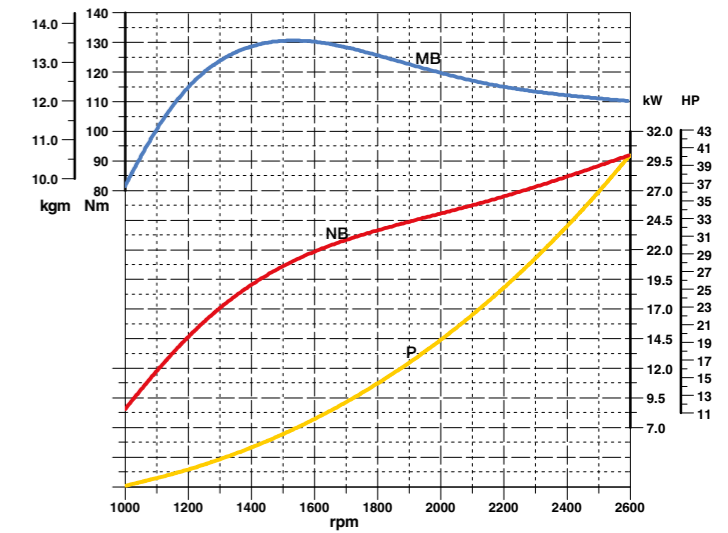

— MB – Torque curve (NB curve)
 — NB – Power curve - ISO 3046/1-IFN
 — P – Propeller demand curve

Power ratings refer to engines equipped with air filter, standard muffler, after running-in period at ambient conditions of +25°C, relative humidity 30% and 1 bar. Power levels drop by 1% every 100 m altitude and by 2% every 5°C above +25°C.

STANDARD EQUIPMENT

- Digital Deluxe-panel
- Alternator 12V - 120A
- Electric starting
- Oil extraction pump
- 100Nm PTO facility
- V-belt safety cover
- Exhaust mixing elbow
- Fresh water expansion tank
- Sea water pump front mounted

ACCESSORIES ON DEMAND

- Set of flexible engine mounts
- Hot water take-off kit
- Second station harness and panel
- Oil pressure sensor for Digital Deluxe-panel

KDI 2504M-MP



Model	KDI 2504M-MP	
Engine specs	4-stroke diesel with cylinder in line	•
	Liquid cooling	•
	4 valves per cylinder	•
	In crankcase camshaft, gear train driven	•
	Pushrod - rocker arms timing with hydraulic tappets	•
	Cast-iron crankcase with bed-plate	•
	Cast-iron cylinder head	•
Technical features	Closed crankcase ventilation system	•
	Cylinder	4
	Bore (mm)	88
	Stroke (mm)	102
	Engine displacement (cm ³)	2482
	Injection system	DI
	Injection Equipment	Mech-Rotary pump
Performance	Starting system	Electric starting 12V
	Alternator	12V-120A
	Emission compliance	EU RCD STAGE2
Performance	Max power (IFN - ISO 3046 and ISO 14396) (Hp@rpm)	50@2600
	Max torque (IFN - ISO 3046 and ISO 14396) (Nm@rpm)	170@1500
Physical characteristics	Dry weight without gear (kg)	285
	Daily service points - positions	1 side service
Auxiliary PTOs	Max torque (Nm)	100

DATA

Dimensions (mm)

KDI 2504M-MP with TMC260 marine gear

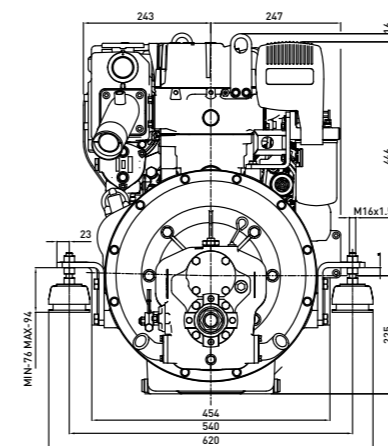
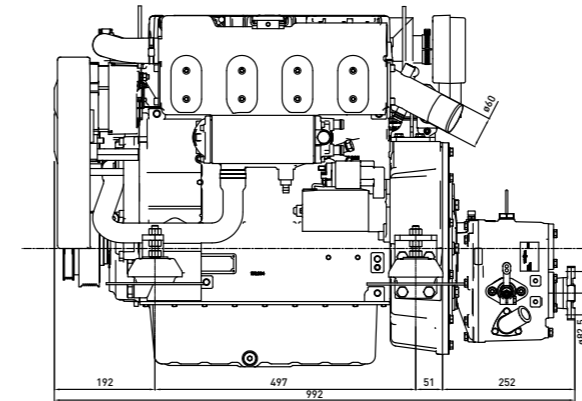

PERFORMANCE CURVES

(ACCORDING TO iso 14396)

KDI 2504M-MP

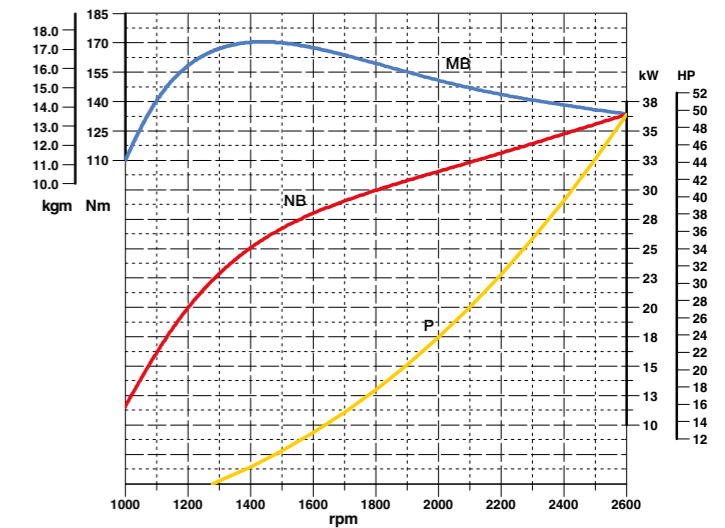

— MB – Torque curve (NB curve)
 — NB – Power curve - ISO 3046/1-IFN
 — P – Propeller demand curve

Power ratings refer to engines equipped with air filter, standard muffler, after running-in period at ambient conditions of +25°C, relative humidity 30% and 1 bar. Power levels drop by 1% every 100 m altitude and by 2% every 5°C above +25°C.

STANDARD EQUIPMENT

- Digital Deluxe-panel
- Alternator 12V - 120A
- Electric starting
- Oil extraction pump
- 100Nm PTO facility
- V-belt safety cover
- Exhaust mixing elbow
- Fresh water expansion tank
- Sea water pump front mounted

ACCESSORIES ON DEMAND

- Set of flexible engine mounts
- Hot water take-off kit
- Second station harness and panel
- Oil pressure sensor for Digital Deluxe-panel

FEATURES AND OPTIONS

Model		KDI 1903TCR-MP	KDI 2504TCR-MP
Engine specs	4 stroke diesel with cylinder in line	•	•
	Liquid cooling	•	•
	4 valves per cylinder	•	•
	In crankcase camshaft, gear train driven	•	•
	Pushrod - rocker arms timing with hydraulic tappets	•	•
	Cast iron crankcase with bed-plate	•	•
	Cast iron cylinder head	•	•
Technical features	Closed crankcase ventilation system	•	•
	Cylinder	3	4
	Bore (mm)	88	88
	Stroke (mm)	102	102
	Engine displacement (cm ³)	1861	2482
	Injection system	DI	DI
	Injection Equipment	Common Rail	Common Rail
Performance	Starting system	Electric starting 12V	Electric starting 12V
	Alternator	12V-120A	12V-100A
	Emission compliance	EU RCD STAGE2	EU RCD STAGE2
	Max power (IFN - ISO 3046 and ISO 14396) (Hp@rpm)	56@2600	74@2600
Physical characteristics	Max torque (IFN - ISO 3046 and ISO 14396) (Nm@rpm)	225@1500	300@1500
	Dry weight without gear (kg)	284	323
Auxiliary PTOs	Daily service points - positions	1 side service	1 side service
	Max torque (Nm)	100	100

Model		KDI 1903M-MP	KDI 2504M-MP
Engine specs	4-stroke diesel with cylinder in line	•	•
	Liquid cooling	•	•
	4 valves per cylinder	•	•
	In crankcase camshaft, gear train driven	•	•
	Pushrod - rocker arms timing with hydraulic tappets	•	•
	Cast-iron crankcase with bed-plate	•	•
	Cast-iron cylinder head	•	•
Technical features	Closed crankcase ventilation system	•	•
	Cylinder	3	4
	Bore (mm)	88	88
	Stroke (mm)	102	102
	Engine displacement (cm ³)	1861	2482
	Injection system	DI	DI
	Injection Equipment	Mech-Rotary pump	Mech-Rotary pump
Performance	Starting system	Electric starting 12V	Electric starting 12V
	Alternator	12V-120A	12V-120A
	Emission compliance	EU RCD STAGE2	EU RCD STAGE2
	Max power (IFN - ISO 3046 and ISO 14396) (Hp@rpm)	40.8@2600	50@2600
Physical characteristics	Max torque (IFN - ISO 3046 and ISO 14396) (Nm@rpm)	133@1500	170@1500
	Dry weight without gear (kg)	240	285
Auxiliary PTOs	Daily service points - positions	1 side service	1 side service
	Max torque (Nm)	100	100

DELUXE PANEL

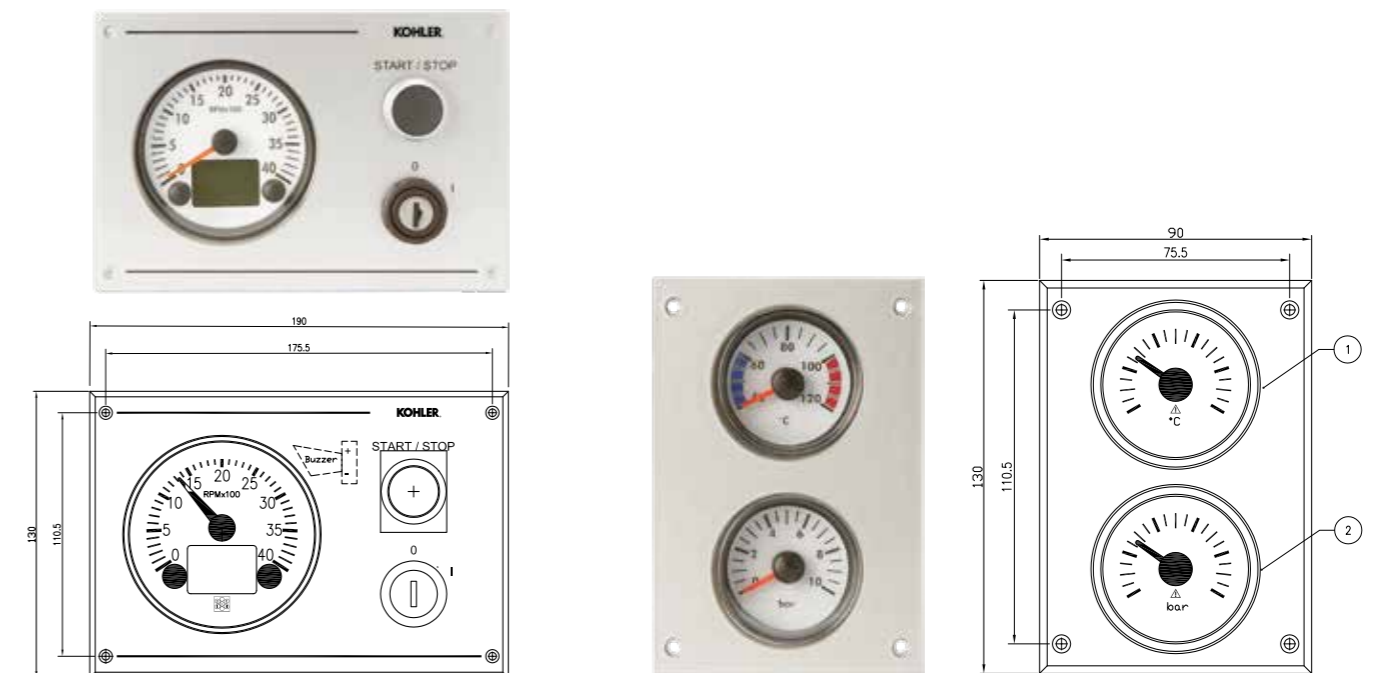

ACCESSORIES

Analogic instruments for water temperature and oil pressure.

PARAMETERS

Rpm; Voltmeter; Hour counter; Cooling water temperature; Oil pressure (on demand).

ALARMS

High fresh water temperature; Low oil pressure; Alternator charge; Service intervals.

RUBBER MOUNTS

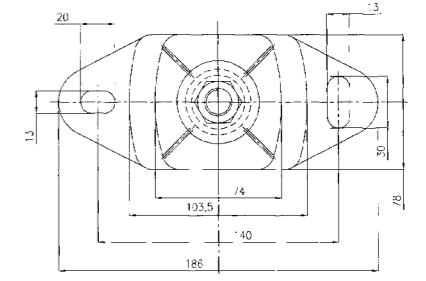
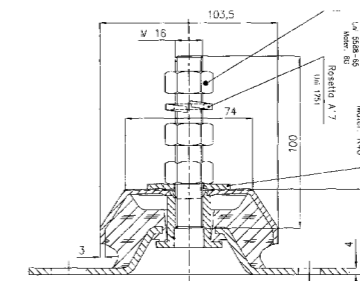



Lombardini Marine is a division
of Lombardini Srl, part of Kohler Group.

SALES OFFICE
Via Cav. del Lavoro A. Lombardini, 2
42124 Reggio Emilia, Italy
T. +39 0522 389311
sales@lombardinimarine.com

WWW.LOMBARDINIMARINE.COM